

"TOP VIEW"

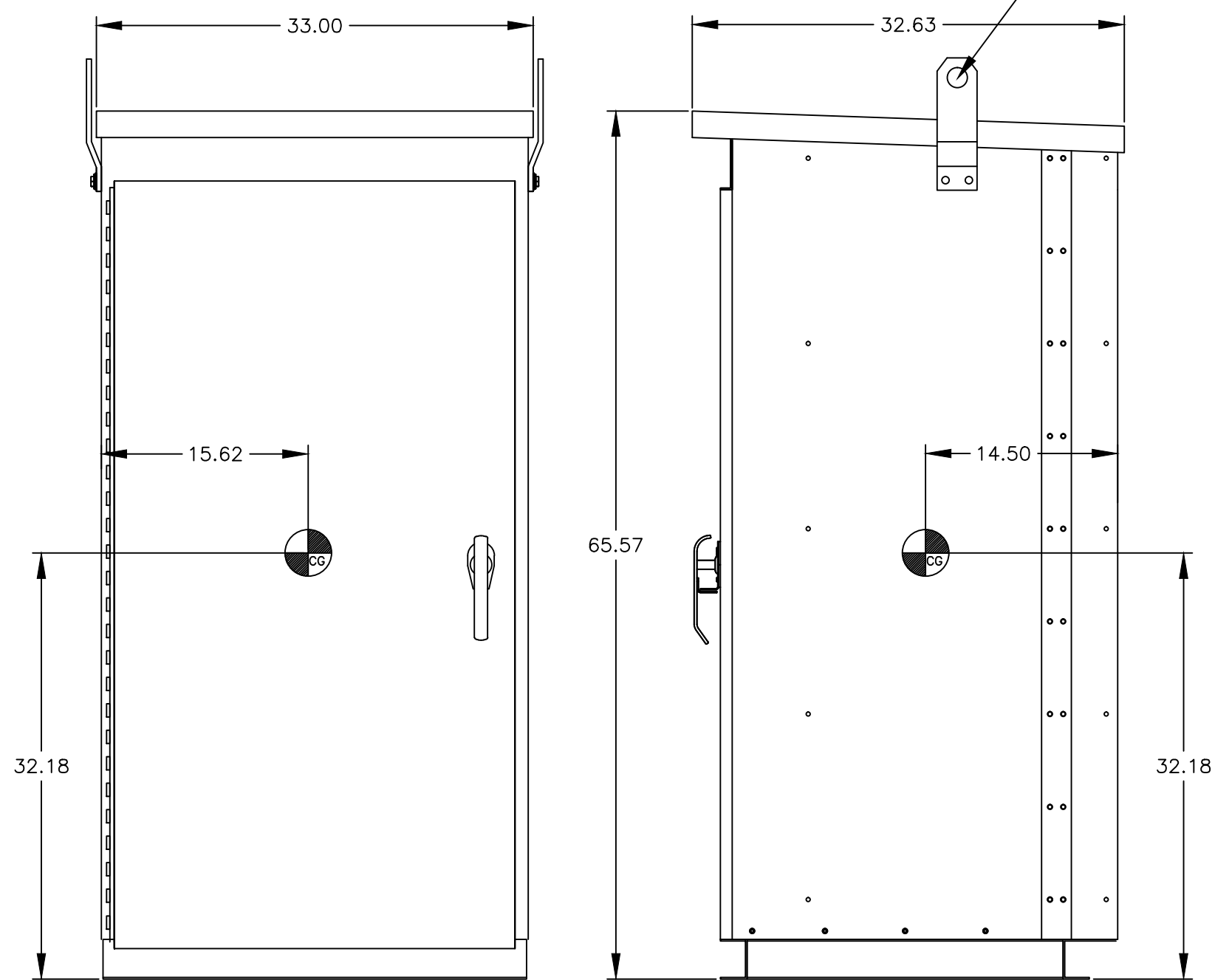

"FRONT VIEW"

"RIGHT SIDE VIEW"

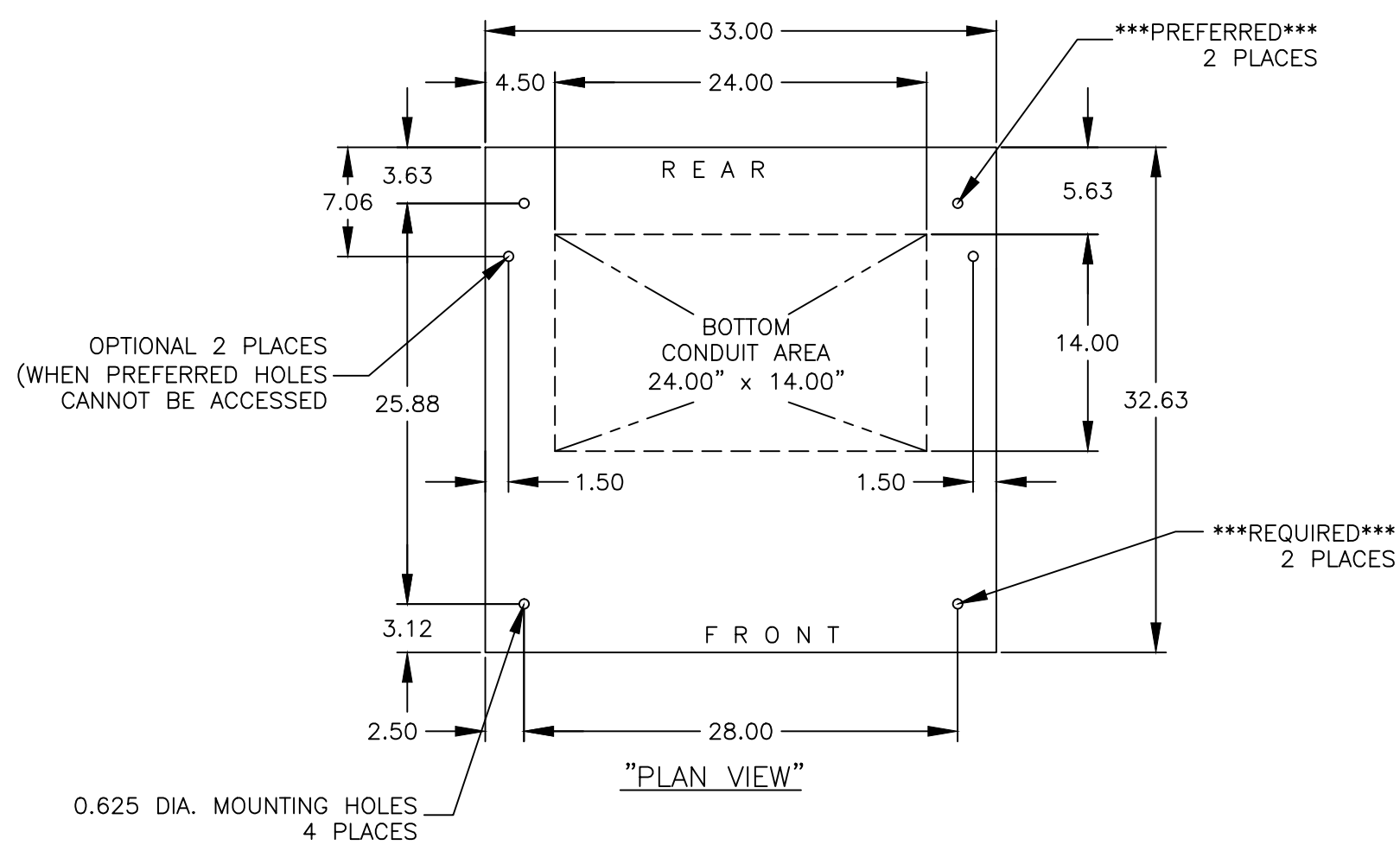

"PLAN VIEW"

CONSTRUCTION NOTES

- FLOOR MOUNTED ENCLOSURE.
TYPE 3R CONSTRUCTED FROM CODE GAUGE STEEL.
FINISH: ANSI 61 GRAY POLYESTER SEMI GLOSS ELECTROSTATIC POWDER.
TYPE 3RX EXTERIOR CONSTRUCTED FROM CODE GAUGE STAINLESS STEEL.
(R) EXTERIOR CONSTRUCTED FROM TYPE 304 STAINLESS STEEL.
(S) EXTERIOR CONSTRUCTED FROM TYPE 316 STAINLESS STEEL.
- EXTERIOR DOORS HAVE PADLOCKABLE HANDLES WITH 3-POINT LATCH
- DESIGNED FOR FRONT ACCESS
- RECOMMENDED CLEARANCES: FRONT: 36 INCHES, REAR: NONE.
- CENTER OF GRAVITY
- APPROXIMATE WEIGHT: 1075 LBS.
- LIFTING PLATES: SECTIONS ARE SUPPLIED WITH LIFTING PLATES.
INSPECT PLATES FOR DAMAGE AND TORQUE BOLTS TO 45 FT LBS BEFORE USE.
REFER TO ANSI/NEMA PB 2.1 FOR PROPER HANDLING OF EQUIPMENT.
AFTER INSTALLATION OF SECTION, REMOVE LIFTING PLATES.
REINSTALL BOLTS INTO EXTERIOR HOLES AND TORQUE TO APROX. 20 FT LBS.

TRANSFER SWITCH

- J FRAME TRANSFER SWITCH 150A - 600A.
- TRANSFER SWITCH RATING: 150 AMPS, 260 AMPS, 400 AMPS, 600 AMPS.
SHORT CIRCUIT RATING: 150A - 600A WCR: 50,000 RMS SYM @ 480V.
THE SOURCES MUST BE PROTECTED BY A REMOTE OVERCURRENT PROTECTION DEVICE AS LISTED ON THE MARKINGS ON THE TRANSFER SWITCH.
- A FULL RATED NEUTRAL CONNECTION FOR EACH SOURCE AND THE LOAD IS OPTIONAL.
WHEN PROVIDED IT IS IN ONE OF THE FOLLOWING FORMATS.
A. SOLID NEUTRAL
B. SWITCHED NEUTRAL POLE

TERMINATIONS 150A - 400A

- SUPPLIED WITH MECHANICAL (SCREW TYPE) LUGS FOR CU/AL CABLE.
NORMAL: (1) #4 - 600MCM OR (2) 1/0 - 250MCM PER PHASE & NEUTRAL
LOAD: (1) #4 - 600MCM OR (2) 1/0 - 250MCM PER PHASE & NEUTRAL
EMERGENCY: (1) #4 - 600MCM OR (2) 1/0 - 250MCM PER PHASE & NEUTRAL
GROUND: (3) #4 - 600MCM OR (6) 1/0 - 250MCM
A. SUITABLE WIRE BENDING SPACE IS PROVIDED AS PER NEC.
- OPTIONAL LUGS MAY BE SUPPLIED.

TERMINATIONS 600A

- SUPPLIED WITH MECHANICAL (SCREW TYPE) LUGS FOR CU/AL CABLE.
NORMAL: (2) #2 - 600MCM PER PHASE & NEUTRAL
LOAD: (2) #2 - 600MCM PER PHASE & NEUTRAL
EMERGENCY: (2) #2 - 600MCM PER PHASE & NEUTRAL
GROUND: (6) #2 - 600MCM
A. SUITABLE WIRE BENDING SPACE IS PROVIDED AS PER NEC.
- OPTIONAL LUGS MAY BE SUPPLIED.

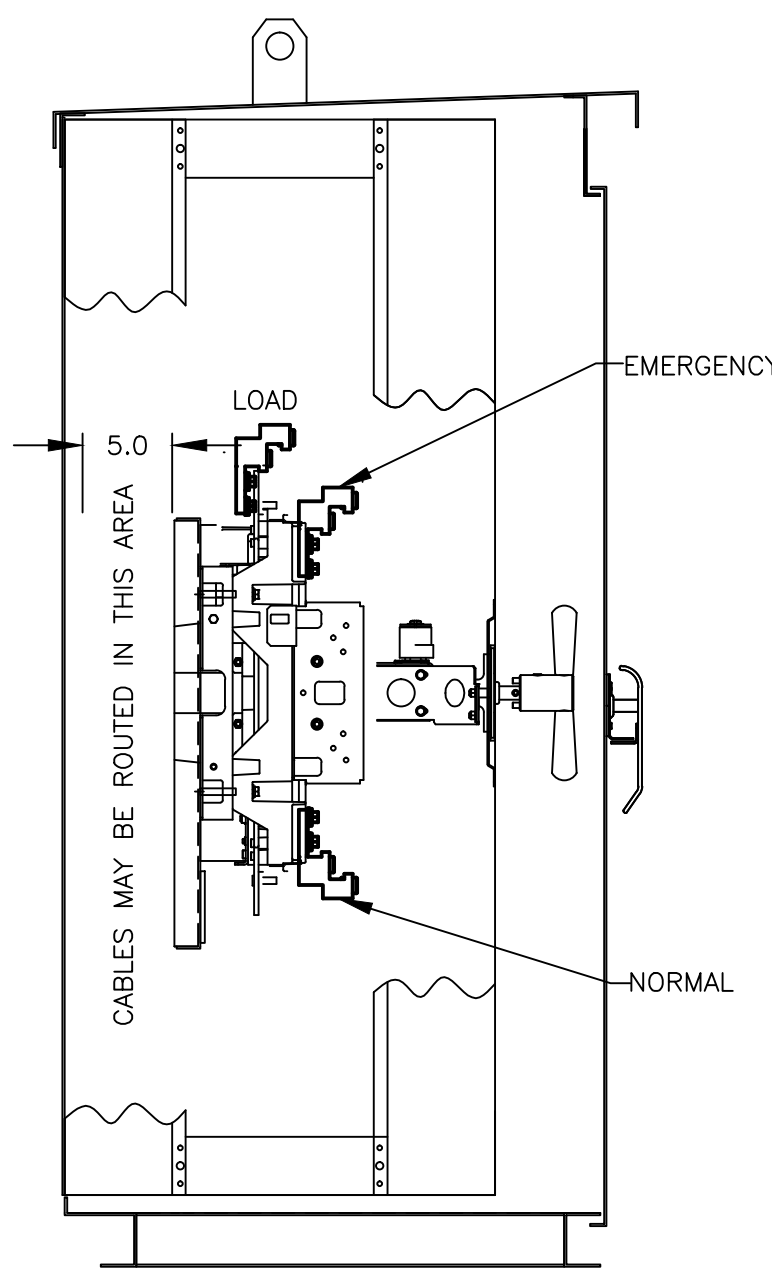

"LEFT SECTION VIEW"

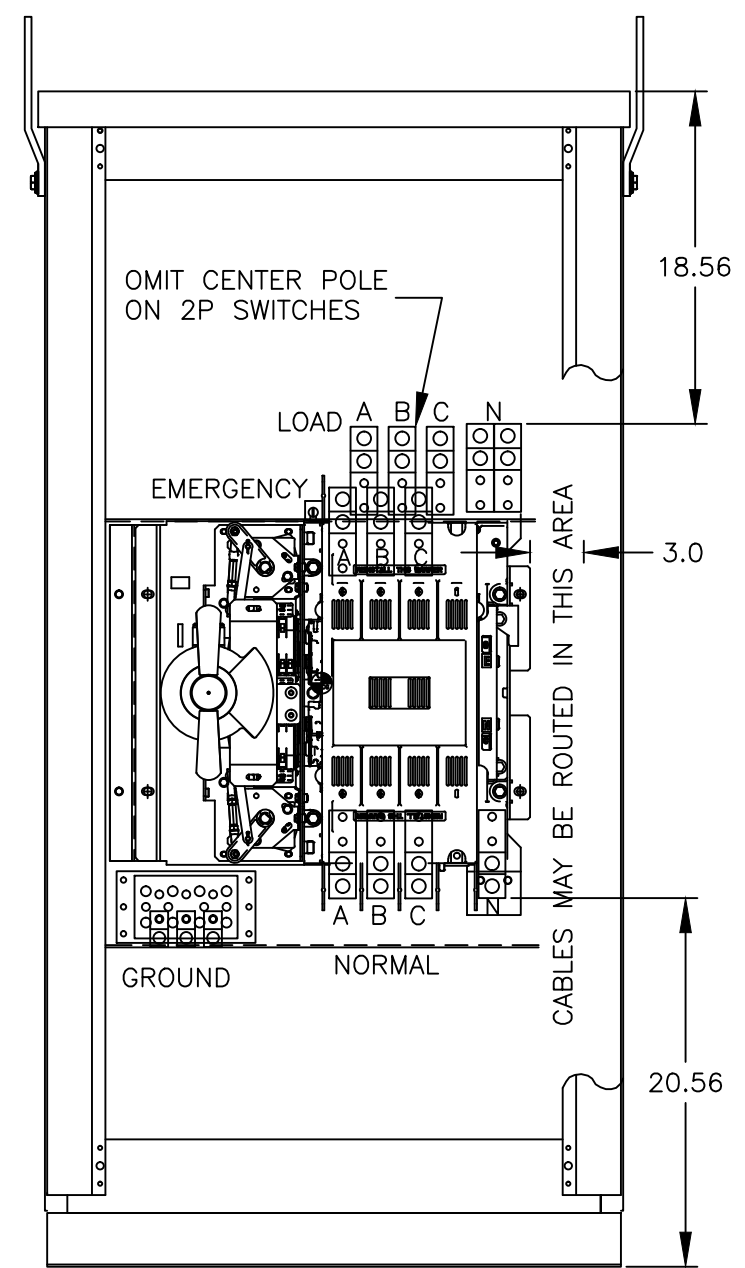

"FRONT VIEW"
"WITHOUT COVER"

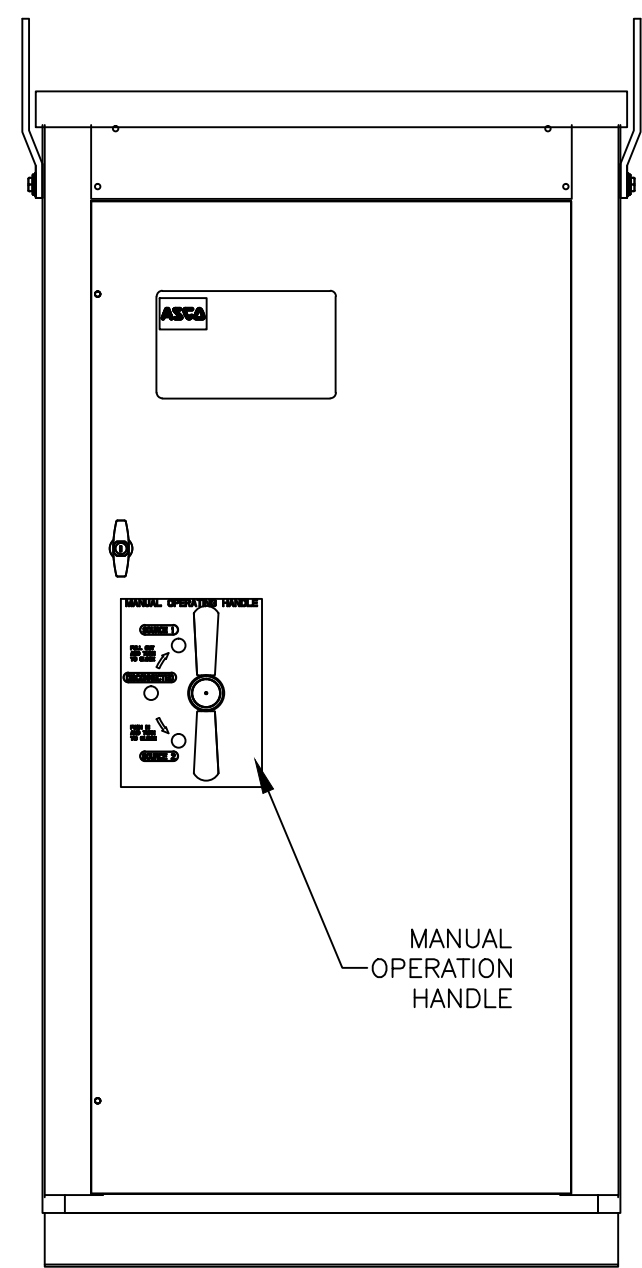

"FRONT INTERIOR VIEW"

PROJECT NAME:		271047	SG	RN	02/09/18
REV. TO SHEET	ECN NO.	BY	APP.	DATE	
OUTLINE		MOUNTING			
JMTS, MANUAL TRANSFER SWITCH 150A - 600A					
TYPE 3R/3RX 66 X 33 X 33					
BY	DATE	MANUFACTURING TOLERANCES TO BE IN ACCORDANCE WITH ASCO PROCEDURE MP-1-003. FOR PLASTIC PARTS SEE MP-1-055		ASSEM. REF. NO.	COMPUTER GENERATED DRAWING
DRAWN BY	SG	02/07/18			SCALE 3/32" = 1" SIZE DS
CHECKED	RN	PROPERTY OF ASCO POWER TECHNOLOGIES. USE PERMITTED FOR OUR WORK ONLY. ALL RIGHTS OF DESIGN OR INVENTION ARE RESERVED.		DWG. NO.	977099-008
PROJECT APPROVAL		ASCO® ASCO POWER TECHNOLOGIES, L.P. FLORHAM PARK, NEW JERSEY 07932 U.S.A.		DRAWING REV.	ECN 271047
FINAL APPROVAL				SHEET	1 OF 1