

CKPOWER®

CKT35KM-T4 FINAL TIER 4 MOBILE RENTAL POWER



Industrial Final Tier 4 Generator Sets

Ratings Range: 60HZ
(3 phase/ .8 power factor)
Prime: 30 kW/ 35 kVA
Standby: 35 kW/ 43 kVA

Features:

- Kubota D2403-CR-BG Tier 4 Final EPA/CARB Certified
- Does not require regeneration
- 75 gallon, 24 Hour run time @ 100% load
- Built with galvanized steel
- Rust prevention hardware (latches, hinges)
- Marathon generator on the standard package, Stamford optional
- Standard configuration: multi-voltage selector switch, 120/240V 1 Phase, 120/208V 3 Phase and 277/480V 3 Phase
- Power Distribution is through single pole camlock or lug connection
- Standard 20 amp 120 volt convenience receptacle included on the unit
- All components are UL1446 certified, CSA certified optional
- Fork pockets and transportation tie downs
- Lockable storage
- Level 1 sound attenuation: 70 dBA @ 23 ft.

Options:

- Battery charger
- Circulating type block heater
- Camlock load connection
- RACOR fuel/water separator
- Auxiliary rental/ convenience receptacles
- Battery disconnect
- Ship to shore
- Trailer mounted storage box
- Fire extinguisher
- DC LED interior enclosure lighting

Control System:

- CK/Deep Sea custom controls
- Easy to use custom configuration
- Monitors engine run hours, coolant temperature oil pressure, battery voltage and fuel level, as well as voltage, amperage, and frequency of the generator
- Auto start capable for all standby applications

*CK Power specification subject to change without notice. *Not responsible for typographical errors. All prices and specifications are subject to change without prior notice. All prices are confidential.



1-855-CKPOWER • CKPOWER.COM

CK GAS



JOHN DEERE

Kubota

KOHLER
IN POWER. SINCE 1920.

VOLVO
PENTA

DSE7310/20

AUTO START & AUTO MAINS FAILURE CONTROL MODULES

FEATURES



The DSE7310 is an Auto Start Control Module and the DSE7320 is an Auto Mains (Utility) Failure Control Module suitable for a wide variety of single, diesel or gas, gen-set applications.

Monitoring an extensive number of engine parameters, the modules will display warnings, shutdown and engine status information on the back-lit LCD screen, illuminated LEDs, remote PC and via SMS text alerts (with external modem).

The DSE7320 will also monitor the mains (utility) supply. The modules include USB, RS232 and RS485 ports as well as dedicated DSENet® terminals for system expansion.

Both modules are compatible with electronic (CAN) and non-electronic (magnetic pick-up/alternator sensing) engines and offer an extensive number of flexible inputs, outputs and extensive engine protections so the system can be easily adapted to meet the most demanding industry requirements.

The extensive list of features includes enhanced event and performance monitoring, remote communications, PLC functionality and dual mutual standby (DSE7310 only) to reduce engine wear.

The modules can be easily configured using the DSE Configuration Suite PC software. Selected front panel editing is also available.

ENVIRONMENTAL TESTING STANDARDS

ELECTRO-MAGNETIC COMPATIBILITY

BS EN 61000-6-2
EMC Generic Immunity Standard for the Industrial Environment
BS EN 61000-6-4
EMC Generic Emission Standard for the Industrial Environment

ELECTRICAL SAFETY

BS EN 60950
Safety of Information Technology Equipment, including Electrical Business Equipment

TEMPERATURE

BS EN 60068-2-1
Ab/Ae Cold Test -30 °C
BS EN 60068-2-2
Bb/Be Dry Heat +70 °C

VIBRATION

BS EN 60068-2-6
Ten sweeps in each of three major axes
5 Hz to 8 Hz @ +/-7.5 mm,
8 Hz to 500 Hz @ 2 gn

HUMIDITY

BS EN 60068-2-30
Db Damp Heat Cyclic 20/55 °C @ 95% RH 48 Hours
BS EN 60068-2-78
Cab Damp Heat Static 40 °C @ 93% RH 48 Hours

SHOCK

BS EN 60068-2-27
Three shocks in each of three major axes
15 gn in 11 mS

DEGREES OF PROTECTION PROVIDED BY ENCLOSURES

BS EN 60529
IP65 - Front of module when installed into the control panel with the supplied sealing gasket.

COMPREHENSIVE FEATURE LIST TO SUIT A WIDE VARIETY OF GEN-SET APPLICATIONS

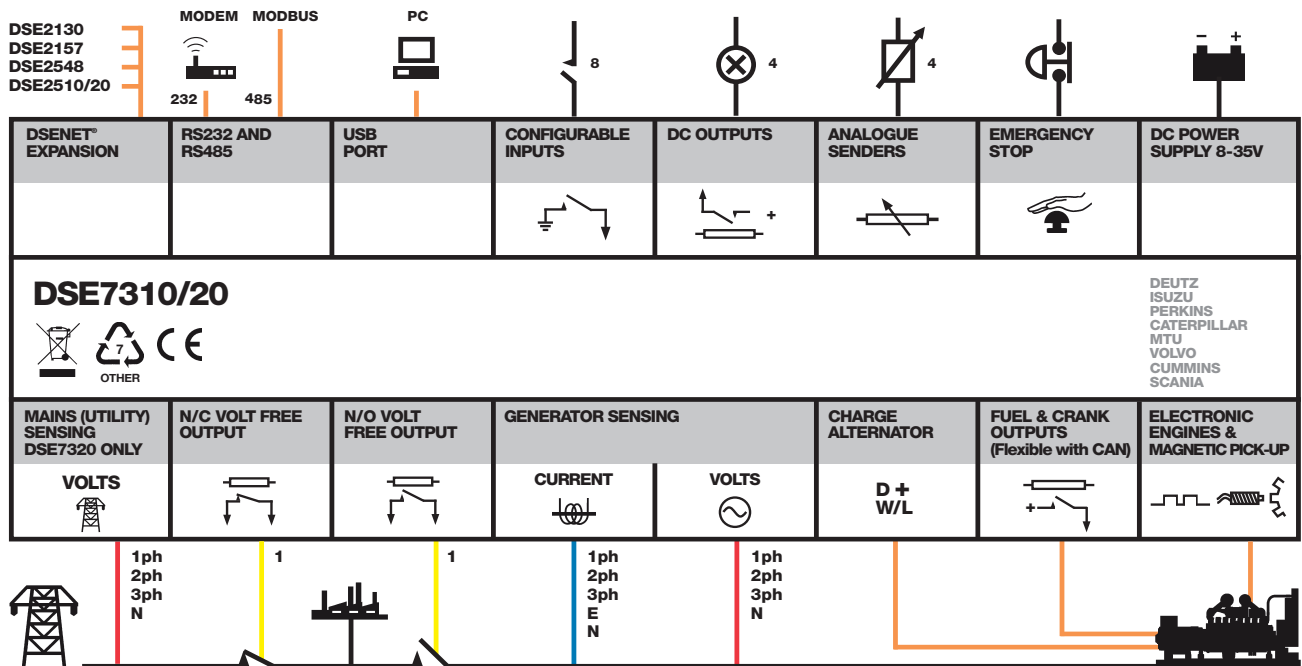

ISSUE 6



1-855-CKPOWER • CKPOWER.COM



DSE7310/20

AUTO START & AUTO MAINS FAILURE CONTROL MODULES

FEATURES

DSE7310



KEY FEATURES

- 4-Line back-lit LCD text display
- Five key menu navigation
- Front panel editing with PIN protection
- Customisable status screens
- Power save mode
- Support for up to three remote display units
- 9 configurable inputs
- 8 configurable outputs
- Flexible sender inputs
- Configurable timers and alarms
- 3 configurable maintenance alarms
- Multiple date and time scheduler
- Configurable event log (250)
- CAN engine support
- Integral PLC editor
- Easy access diagnostic page
- CAN and Magnetic Pick-up/Alt. sensing
- Fuel usage monitor and low fuel alarms
- Charge alternator failure alarm
- Manual speed control (on compatible CAN engines)
- Manual fuel pump control
- Engine exerciser
- "Protections disabled" feature
- kW & kV Ar protection

RELATED MATERIALS

TITLE

DSE7310 Installation Instructions
 DSE7320 Installation Instructions
 DSE7200/7300 Quick Start Guide
 DSE7200/7300 Operator Manual
 DSE7200/7300 Configuration Suite PC Manual

DSE7320



- Reverse power (kW & kV Ar) protection
- LED and LCD alarm indication
- Power monitoring (kW h, kV Ar, kV A h, kV Ar h)
- Load switching (load shedding and dummy load outputs)
- Automatic load transfer (DSE7320)
- Unbalanced load protection
- Independent Earth Fault trip
- True dual mutual standby with load balancing timer (DSE7310 only)
- USB connectivity
- Backed up real time clock
- Fully configurable via DSE Configuration Suite PC software
- Configurable display languages
- Remote SCADA monitoring via DSE Configuration Suite PC software
- User selectable RS232 and RS485 communications
- Configurable Gencomm pages
- Advanced SMS messaging (additional external modem required)
- Start & stop capability via SMS messaging
- Additional display screens to help with modem diagnostics
- Idle control for starting & stopping.

- DSENet® expansion compatible
- Heated display option available

KEY BENEFITS

- 132 x 64 pixel ratio display for clarity
- Real-time clock provides accurate event logging
- Multiple date and time scheduler
- Set maintenance periods can be configured to maintain optimum engine performance
- Ethernet communications (via DSE855 module), provides advanced remote monitoring
- Modules can be integrated into building management systems (BMS)
- Increased input and output expansion capability via DSENet®
- Licence-free PC software
- IP65 rating (with supplied gasket) offers increased resistance to water ingress
- PLC editor allows user configurable functions to meet specific application requirements

PART NO'S

053-028
 053-029
 057-101
 057-074
 057-077

SPECIFICATION

DC SUPPLY

CONTINUOUS VOLTAGE RATING

8 V to 35 V Continuous

CRANKING DROPOUTS

Able to survive 0 V for 50 mS, providing supply was at least 10 V before dropout and supply recovers to 5 V. This is achieved without the need for internal batteries. LEDs and backlight will not be maintained during cranking.

MAXIMUM OPERATING CURRENT

340 mA at 12 V, 160 mA at 24 V

MAXIMUM STANDBY CURRENT

160 mA at 12 V, 80 mA at 24 V

CHARGE FAIL/EXCITATION RANGE

0 V to 35 V

MAINS (UTILITY) DSE7320 ONLY VOLTAGE RANGE

15 V to 415 V AC (Ph to N)
 26 V to 719 V AC (Ph to Ph)

FREQUENCY RANGE

3.5 Hz to 75 Hz

OUTPUTS

OUTPUT A (FUEL)

15 A DC at supply voltage

OUTPUT B (START)

15 A DC at supply voltage

OUTPUTS C & D

8 A 250 V (Volt free)

AUXILIARY OUTPUTS E,F,G,H

2 A DC at supply voltage

GENERATOR

VOLTAGE RANGE

15 V to 415 V AC (Ph to N)
 26 V to 719 V AC (Ph to Ph)

FREQUENCY RANGE

3.5 Hz to 75 Hz

MAGNETIC PICK UP

VOLTAGE RANGE

+/- 0.5 V to 70 V

FREQUENCY RANGE

10,000 Hz (max)

DIMENSIONS

OVERALL

240 mm x 181 mm x 42 mm
 9.4" x 7.1" x 1.6"

PANEL CUT-OUT

220 mm x 160 mm
 8.7" x 6.3"

MAXIMUM PANEL THICKNESS

8 mm
 0.3"

OPERATING TEMPERATURE RANGE

-30°C to +70°C

STORAGE TEMPERATURE RANGE

-40°C to +80°C

1-855-CKPOWER • CKPOWER.COM



JOHN DEERE



CKV4550 MOBILE RENTAL POWER SINGLE AXLE TRAILER

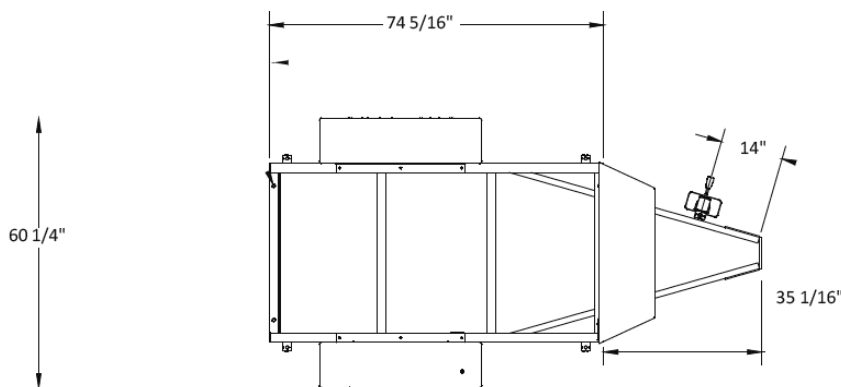
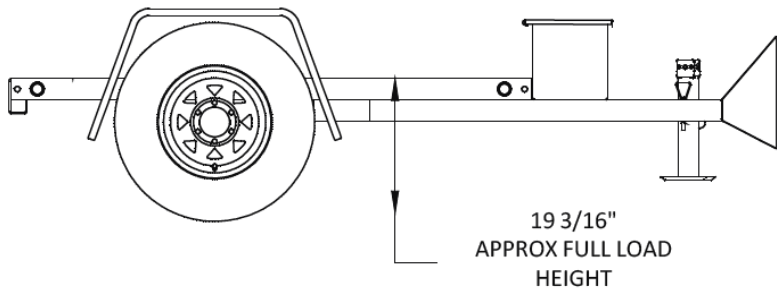
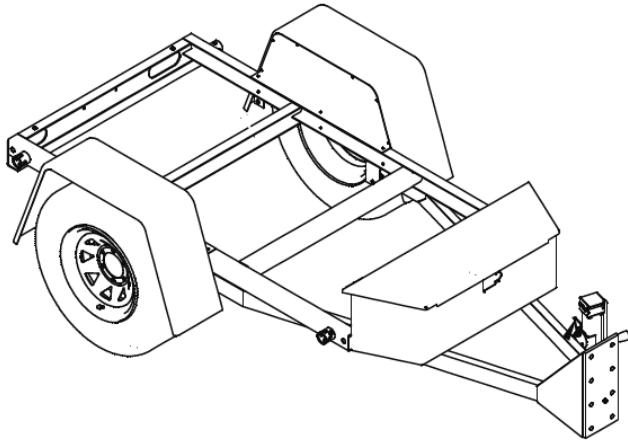

Features:

- DOT approved on road trailer
- Single 3,500lbs torflex axles
- Electrical drum brakes
- Diamond plated, weather grip fenders/ step
- DOT approved LED lighting package/Running lights
- Transportation tie downs on all corners
- 2K adjustable top line jack
- 5/16" Transportation Chain, Grade 70/ Clevis W/ safety latch, 5/16, Grade 70
- Wiring conduit inside tube frame
- Formed galvanized steel
- H.D. welded steel frame
- TCI Powder coated
- 7 Pole RV connector

Options:

- Rear stabilizer stands
- Spare tire with lockable mount
- Bolt-on rear step ladder
- 500-watt flood light
- Wheel chocks
- Tongue mounted storage box
- Locking wheel boot
- Pintle eye lock

Hitch Options:

- 3" Pintle Eye
- 2-5/16" Ball Coupler

* CK Power specification subject to change without notice.

* Not responsible for typographical errors. All prices and specifications are subject to change without prior notice. All prices are confidential. Reproduction or distribution without express permission by CK Power is prohibited.



1-855-CKPOWER • CKPOWER.COM



JOHN DEERE

