



Quick Connection Panel (QCP)

Installation Guide



HAZARD OF ELECTRICAL SHOCK, EXPLOSION, OR ARC FLASH

- Read this document first.
- The installer is responsible for compliance with National Electrical Code requirements with respect to installation of this equipment.
- Many components of this equipment operate at line voltage. DO NOT TOUCH. Use only electrically isolated tools.
- Install and close all covers before applying power to this equipment
- Do not open covers to equipment until ALL power sources are disconnected
- This equipment must be installed and serviced only by qualified electrical personnel utilizing safe work practices and appropriate Personal Protective Equipment (PPE).

Failure to do so may cause personal injury or death.



A. Introduction

Thank you for purchasing this Thomson Power Systems product. This installation guide applies to the **Quick Connection Panel (QCP)** single pole inlet junction box. The QCP is designed to interface an Automatic Transfer Switch to a portable generator for temporary power connections. The QCP is shipped pre-assembled, and is constructed of powder coated galvaneal enclosure, with a safety hinged bottom cable entry panel. It is NEMA3R with gaskets, Series 16 type inlet connectors (male), lugs, and snap-covers.

The Quick Connection Panel can be used on any ATS between 100A to 1200A with the following models:

- QCP-0400-A
- QCP-0800-A
- QCP-1200-A

NOTE: This installation guide is typical for all QCP models.

B. Installation Requirements

Before installing the Quick Connection Panel (QCP) review the following requirements:

- 
 - **Preparation:** Follow proper & safe workmanship. Protect equipment from metal debris when making panel cutouts. All power connections must be disconnected, isolated, insulated and protected from debris. Clean & inspect prior to re-energizing equipment.
 - **Control Wiring:** All control wiring for engine start, load shed, alarm and remote test must be installed in separate conduits from all power cabling and must utilize suitably sized conduits per NEC requirements. All control wiring shall be sized for minimum #14 AWG. Control wiring type and voltage rating must also comply with NEC requirements and local jurisdictions having authority.
 - **Power Cabling:** All power cabling entering and exiting the enclosure must be installed in suitably sized conduit per NEC requirements. Ampacity and voltage rating of current carrying conductors must also comply with NEC & UL 1008 requirements as well as comply with local jurisdictions having authority.

1) QCP TO ATS POWER CONDUCTOR INSTALLATION

The QCP is designed to be cabled to the Emergency side of the ATS and is provided with lugs sized for the maximum amperage as indicated by the QCP model number. The lugs provided are sized for Copper cable installations, larger lugs may be required for Aluminum cables.

Refer to the ATS brochure and ATS manual for the appropriate cable size and quantity per phase. All power cables are to be installed and torqued on the lugs per values indicated in the ATS installation manual. Refer to UL 1008 Ampacity of Insulated Conductors Table to determine minimum cable size and quantity. Torque as per the ATS cable torque specs.

Example: 800A Installation:

- 3 conductors per phase and neutral minimum
- UL 1008 Ampacity of Insulated Conductors Table lists a 75°C copper cable sized at 300 kcmil is good for 285A.
- Number of conductors is 3 x 285A = 855A.

Therefore running 3 x 300kcmil cable will be adequate.

QCP	AMPS	QTY/PHASE	SIZE	TYPE
QCP-A0400A	400	2	#6-250MCM	CRIMP LUGS
QCP-A0800A	800	3	#6-300MCM	SCREW LUGS
QCP-A1200A	1200	4	#6-350MCM	SCREW LUGS



WARNING: Failure to properly install and adequately tighten power cable connections can result in equipment malfunction and/or damage.



NOTE: Before megger testing is conducted, the Transfer Switch electronic controller must be isolated from the power wiring. Failure to isolate the controller for megger testing can result in equipment malfunction and/or damage.

Ampacity of insulated conductors

(refer to 6.13.1.4 and 6.13.3.2)

Wire size		60°C (140°F)		75°C (167°F)	
mm ²	AWG or kcmil	Copper	Aluminum	Copper	Aluminum
0.20	24	2	—	—	—
0.32	22	3	—	—	—
0.52	20	5	—	—	—
0.82	18	7	—	—	—
1.3	16	10	—	—	—
2.1	14	15	—	15	—
3.3	12	20	15	20	15
5.3	10	30	25	30	25
8.4	8	40	30	50 [45 ^b]	40 [30 ^b]
13.3	6	55	40	65	50
21.2	4	70	55	85	65
26.7	3	85	65	100	75
33.6	2	95 [100 ^b]	75	115	90
42.4	1	110 ^a	85 ^a	130	100
53.5	1/0	125	100	150	120
67.4	2/0			175	135
85.0	3/0			200	155
107.2	4/0			230	180
127	250			255	205
152	300			285	230
177	350			310	250
203	400			335	270
253	500			380	310
304	600			420	340
355	700			460	375
380	750			475	385
405	800			490	395
456	900			520	425
507	1000			545	445
633	1250			590	485
760	1500			625	520
887	1750			650	545
1010	2000			665	560

^a If the transfer switch is marked to indicate that 75°C (167°F) wire shall be used at the terminal, the acceptable current is 130 A for a copper conductor and 100 A for an aluminum conductor.

^b Values in [] apply in Canada.

NOTES

1. For a multiple-conductor at a terminal, the value shall be multiplied by the number of conductors that the terminal accommodates (53.5 mm² (1/0 AWG) or larger).

2) QCP ACCESSORIES:

- A. Engine Start: Two terminal blocks are provided to wire the Engine start contacts from the ATS to the QCP. The engine start wires should be run in a separate conduit or TEK CABLE. Do not route the Engine Start wires along highly inductive switching cables.
- B. Phase Monitor Relays: There are two phase monitor options
 - 1. ABB – CM-PFS.S is provided on QCP up to 480 Vac.
 - Warning: When using the CM-PFS.S the maximum voltage of the QCP is 480Vac.
 - 2. ABB – CM-MPN.62S is provided on QCP between 480-600Vac or if the advanced options required.
 - 3. The Phase Monitor Relay is factory wired and installed on the same bracket as the Engine Start terminal blocks.
 - 4. Refer to enclosed Phase Relay manual for operational instructions.



are

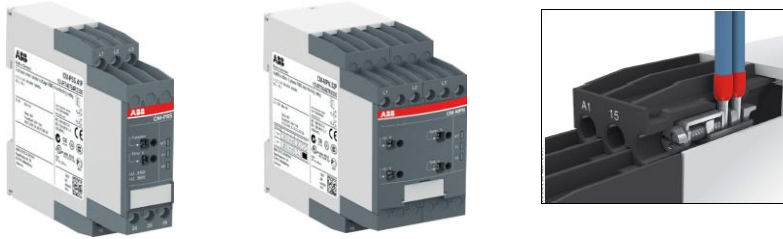

3) GENERATOR POWER CABLE CONNECTIONS:

The QCP is equipped with a hinged bottom door, with two locks. To install the power cables, unlock the tabs on either side and unfold the bottom cable door. Ensure the Generator is OFF and connect the power cables to the corresponding phases. Cable Color Code:

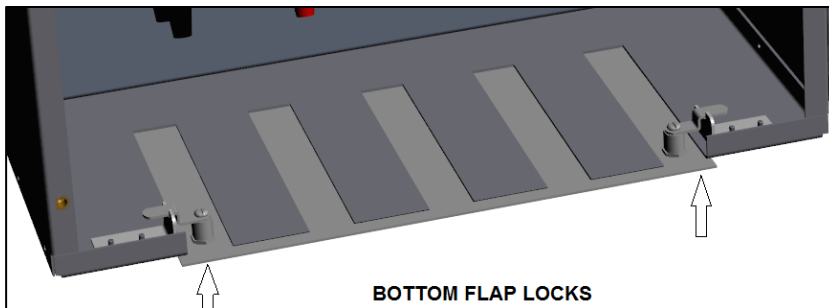

COUNTRY COLOR CODE		
PHASE	USA (480Vac)	CANADA (600Vac)
A (L1)	BLACK	RED
B (L2)	RED	BLACK
C (L3)	BLUE	BLUE
Neutral	WHITE	WHITE

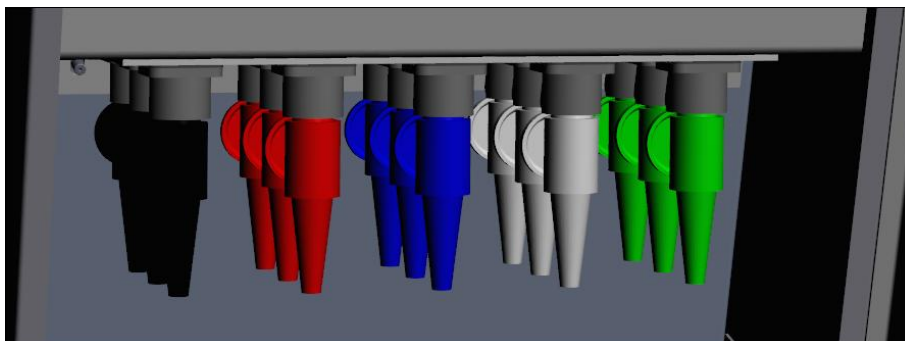

Equipment Energization



HAZARD OF ELECTRICAL SHOCK, EXPLOSION, OR ARC FLASH

- This equipment must be serviced only by qualified electrical personnel utilizing safe work practices and appropriate Personal Protective Equipment (PPE).
- Many components of this equipment operate at line voltage. DO NOT TOUCH. Use only electrically isolated tools.

Failure to do so may cause personal injury or death

1. Confirm Utility, Generator and loads can be energized in a safe manner.
2. Energize utility supply and confirm voltage and phasing is correct at the source.
3. Run the generator manually and confirm generator supply voltage and phasing is correct at the source.
4. Using appropriate personal protective equipment (PPE) and insulated tools/meters, remove the transfer switch front cover while energized.
5. Verify at the transfer switch (while energized), the utility and generator supply voltage, phasing and phase rotation is correct.
6. Manually stop generator and place the generator controls in the "AUTOMATIC" position.
7. Test Automatic operation as per the ATS Manual.

Figure 1: QCP Mechanical Drawing

