

# X100L

## Ultra Light Resistive Load Bank 100kW



ISO 9001:2015 Registered



Unit Weighs 64 lbs.

### Standard Features

1. Digital meter with USB-Type B dataport
2. Recessed control panel to protect controls
3. Voltage and temperature warning lamps
4. 400 amp camlock power connections
5. Lightweight aluminum body
6. 120V auxiliary power receptacle
7. Quiet, high-speed cooling fans

### Applications

- Generator Maintenance
- Uninterrupted Power Supplies
- Data Centers
- Renewable Energy
- OEM's

Mosebach's X100L load bank offers you a continuous load at 480/240/208 volts in a compact, ultra lightweight, indoor enclosure.

The digital meter allows you to measure power, voltage, current and frequency while also allowing you to record the data as you do your testing.

Power connections are easily done with our camlock connections. Auxiliary power of 120V is used for blower and control power. You should be up and testing within minutes of connecting your power source.

[WWW.STEADYPOWER.COM](http://WWW.STEADYPOWER.COM)

1-888-331-5344

# X100L

## Ultra Light Resistive Load Bank 100kW

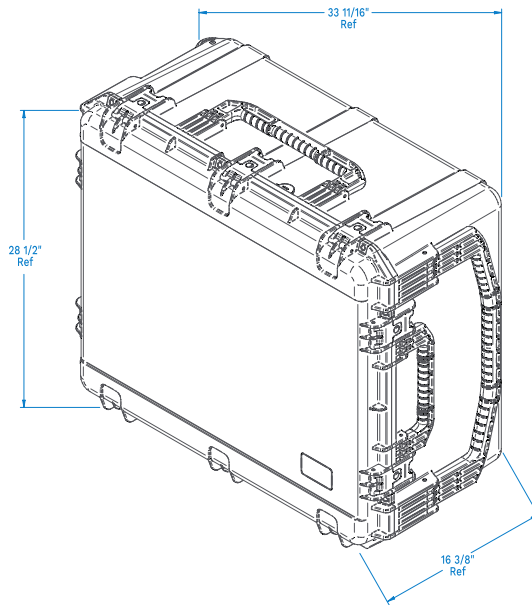
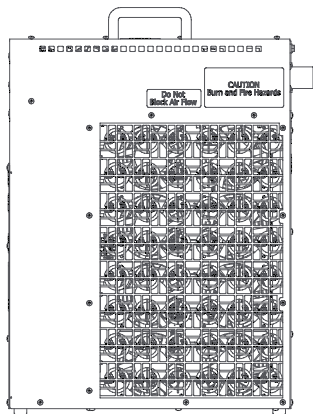
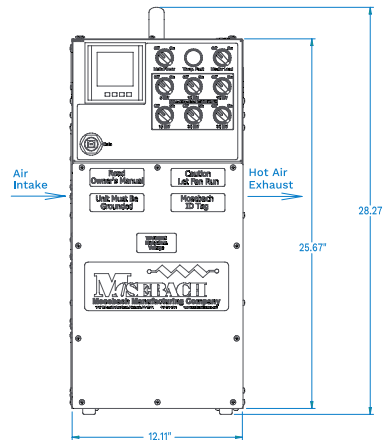
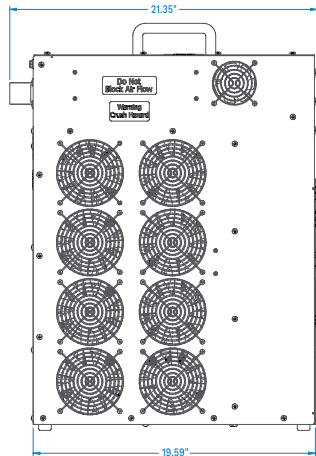

### Ratings of X100L:

kW	VOLTAGE	RESOLUTION
■ 100	480	5
■ 100	240	5
■ 75	208	3.75
■ 66	240/1	3.3
■ 16.5	120/1	0.83

### Standard Configuration

#### Digital Meter

- To measure current, voltage and frequency
- Data logging to store tests to laptop

#### Safety

- Over temperature and over voltage sensors
- Ground Camlock

#### Carrying Case

- 100% waterproof case
- Industrial strength injection molded case
- Gasket sealed, water and dust tight, submersible design
- Weight 38 lbs.

### Option Add-Ons (Select Desired)

#### OPTIONAL KITS

- Extended 2 Year Warranty
- Extended 3 Year Warranty
- Starter Spare Parts Kit

#### OPTIONAL ACCESSORIES

- 10 ft. Cable Set
- 25 ft. Cable Set
- 50 ft. Cable Set
- 100 ft. Cable Set
- Nationally Recognized Test Lab (NRTL) Approval

Model No.	Voltage	Total kW	Resolution (kW)	Dimensions L x W x H	Weight (lbs.)
X30LT	480	30	1	20" x 12" x 29"	60
X60C	416	60	3	22" x 14" x 27"	84
X100L	480	100	5	20" x 12" x 29"	64
X100L-600	600	100	5	20" x 12" x 29"	64
X250S	480	250	5	43" x 25" x 44"	250

[WWW.STEADYPOWER.COM](http://WWW.STEADYPOWER.COM)

1-888-331-5344

# X100L

## Ultra Light Resistive Load Bank 100kW



### Multi-Unit Controller Software

Mosebach's Multi-Unit Remote Controller Software is designed to help manage a single load bank or multiple load banks as one. It is able to be installed and run on any laptop.

The hardware consists of an I/O card that is installed in each load bank. The MURC™ can help manage a group of load banks to get the full load that is needed at the testing site.



### Mosebach's Cross Wire Resistors

Mosebach's Cross Wire Resistor have no ceramics and therefore are lighter and more durable than any other resistor on the market today. The resistors are supported by high temperature Mica supports that have been proven in Dynamic Braking Systems for locomotives and mining trucks all over the world. We are so confident in our resistor technology they come with a 2 year warranty, standard!

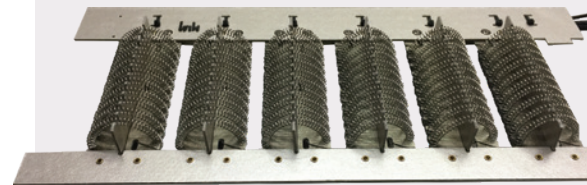

X100L 01/22