

# ROTOVERTER®

RONK ELECTRICAL INDUSTRIES, INC. NOKOMIS, IL 62075

## FIELD INSTALLATION & OPERATION INSTRUCTIONS

The Ronk ROTOVERTER rotary converter consists of a rotary transformer and one or more capacitor panels. For UL Listed units, the rotary transformer and capacitor panels must be used together to maintain their listing.

This manual will answer most of the questions you may have about the basic installation and operation of the converter. See Section 455 of the National Electric Code for more information on phase converter installations. If you have any additional questions, please contact our Service Department at (217) 563-8333.

### CONNECTION

All wiring should be done by a qualified electrician in accordance with all applicable electrical codes. Diagram A shows the basic connections between the converter, the single-phase power, and the three-phase load.<sup>[1]</sup> The ROTOVERTER is voltage specific and must match the supply voltage unless transformers are being used. Verify that the supply voltage matches the ROTOVERTER nameplate and panel nameplate voltages. The capacitors in Panel #1 are connected at factory across the “A” and “B” phases (See Diagram A, Note #1). The incoming single-phase lines should connect to the “L1” and “L2” positions of the terminal block and will become the “B” & “C” phases of the three-phase output (“A” phase is the manufactured phase). Use the “B” and “C” phases for any controls and single-phase loads if they are being powered from the converter. Do not connect control circuits, control transformers, or other single-phase loads to the “A” phase (See Diagram A, Note #4). Doing so may damage their components and/or result in improper operation. Refer to the load equipment information for any single-phase connections.

1. Additional suffixes to the TYPE rating indicate additional components and/or alternate configuration. Check the wiring diagram in your unit's capacitor panel for wiring information specific to your converter. Diagram A in this manual is general and shows the basic connections.

### ROTARY OPERATION

The #1 capacitor panel provides the current to start your rotary transformer and operate your three-phase load. The converter always must be fully up to speed (1-3 seconds) before any load is applied. Diagram C is a check list for the converter's output voltages (at idle and loaded conditions). It is a good idea to check and record these voltages, so you have a set of reference voltages. When the ROTOVERTER is running idle (three-phase load shut off), all the capacitor current flows into the rotary transformer. That is why the rotary transformer gets warm to the touch when it is idling. When a load operates, most of the capacitor current now flows to the load instead, so the rotary transformer will actually cool down under load. Due to the heating effect of the capacitor current, avoid operating the converter at idle for extended periods, if possible. Because the capacitors' current flows into the rotary transformer at idle, any additional capacitor panels must not be directly connected to the rotary transformer or damage may occur to the rotary transformer.

### SECONDARY PANELS (i.e. Capacitor Panel #2)

When a unit is supplied with an additional capacitor panel(s), connect the additional panel(s) to the load side of the last device (starter, contactor, etc.) controlling a load (See Diagram A, Note #2). This connection assures that when the three-phase loads are off (rotary idling), the current from the extra capacitor panel(s) does not flow into the rotary transformer. If any additional capacitor panel is connected directly to the rotary transformer when no three-phase load is operating, the extra current from these capacitors can damage the rotary transformer. Note that the additional panel connects ahead of

the starter's overloads, so the actual motor current flows through the overloads. If the motor starter does not have a place between the contacts and the overloads to attach the additional panel, contact our Service Department for alternate ways to connect it. Take extra care to assure the proper phasing of any additional panels; the "A" phases of all panels must connect to the converter's "A" phase, the "B" phases to the converter's "B", and the "C" phases to the converter's "C". The best way to identify the phases is to read the "motor-off" phase-to-phase voltages (See Diagram C – idle conditions) at the starter where the panel will be connected. The secondary panel should always be across the two legs that have the highest phase-to-phase voltage (A-B).

## **STARTUP**

The ROTOVERTER is prewired at factory for only one voltage. Verify that the voltage ratings on the rotary, capacitor panels, and supply all match. If the single-phase line is above 250 volts for 240 volt units (or 500 volts for 480 volt units), the capacitor amperage should be checked. With the ROTOVERTER idling, clamp around the "A" lead from the terminal block (or all of the blue wires from the capacitors) in the #1 panel and compare the measured capacitor amperage to the BASE 3Ø amperage rating on the rotary transformer's nameplate (Diagram D). If the capacitor amperage exceeds the BASE 3Ø amperage, one or more capacitors in the panel #1 should be disconnected. To disconnect a capacitor, simply remove the quick-disconnect jumper wires that connect it to the other capacitors. The high single-phase voltage may also damage the load equipment. Refer to load equipment information for voltage tolerances.

When line voltage is considerably less than 240 (or 480) volts, it may be necessary to add additional capacitance to the system (voltage drop problems may also exist). Check this by measuring the voltage across the capacitors while the load is operating. If the capacitor voltage is less than the incoming single-phase voltage, then the extra capacitance may be necessary. If the single-phase voltage is also dropping, then this would indicate a voltage drop and/or an overload problem. Consult our Service Department if there are any questions.

If the rotary transformer isn't up to speed within 3 seconds, verify that the rotary, panel, and single-phase are properly connected. Then check for and correct any single-phase voltage drop problems that may exist. If a load motor is operating a high inertia load or a load requiring a large amount of torque to start, then an auxiliary start panel may be required. An auxiliary start panel boosts starting voltage and current, thereby improving starting torque and acceleration. These starting panels also connect to the load side of the motor's starter, ahead of the overloads (See Diagram A, Note #3). See the Trouble Shooting Chart for other causes; consult the Service Department if you need assistance.

## **BALANCING**

Check the motor currents with the load applied to the equipment; be sure to always check the current on the load side of the motor starter. False current readings can be obtained by reading on the line side when secondary capacitor panels are used. Record the currents on the A, B, and C phases. Adjustments can be made to the ROTOVERTER Tap and capacitors may be connected or disconnected. If tap adjustments are necessary, reconnect X lead to L or H and insulate the remaining taps separately.

- 1) If "A" current is considerably higher than "C", a light load condition is indicated. If "A" is near FLA and "B" and "C" currents are higher, an overload condition is indicated. If either of these conditions exists, verify load is correct before proceeding with balancing.
- 2) If "A" is highest with "C" low and you have verified the motor is lightly loaded, disconnect some capacitance to bring "A" down and "C" up. Panel #1 is energized all the time. Panel #2 is energized only when the motor it is connected to is running.
- 3) If "A" is lower than "B" and "C", more capacitance needs to be connected.
- 4) If "B" is significantly higher than "C", then X lead needs to be moved to a LOWER Tap.
- 5) If "B" is significantly lower than "C", then X lead needs to be moved to a HIGHER Tap.

# TYPICAL INSTALLATION

ALL WIRING SHOULD BE DONE BY A QUALIFIED ELECTRICIAN IN ACCORDANCE WITH ARTICLE 455 OF THE NATIONAL ELECTRIC CODE® AND ALL OTHER APPLICABLE CODES. SEE "DIAGRAM D" FOR FLA RATING LOCATIONS ON ROTARY AND PANEL NAMEPLATES.

DO NOT CONNECT CONTROL CIRCUITS OR OTHER 1Ø LOADS TO "A" PHASE (PHASE WITH HIGHEST VOLTAGE TO GROUND) FROM THE CONVERTER. REFERENCE NEC ARTICLE 455.9

SEE ARTICLE 250 OF NEC FOR PROPER GROUNDING OF ALL ENCLOSURES.

\* THREE-PHASE CONDUCTORS SIZED FOR LOAD IN ACCORDANCE WITH NEC. IF UNIT IS SUPPLIED WITH CAPACITOR PANEL #2, WE RECOMMEND USING THE NEXT SIZE LARGER WIRE.

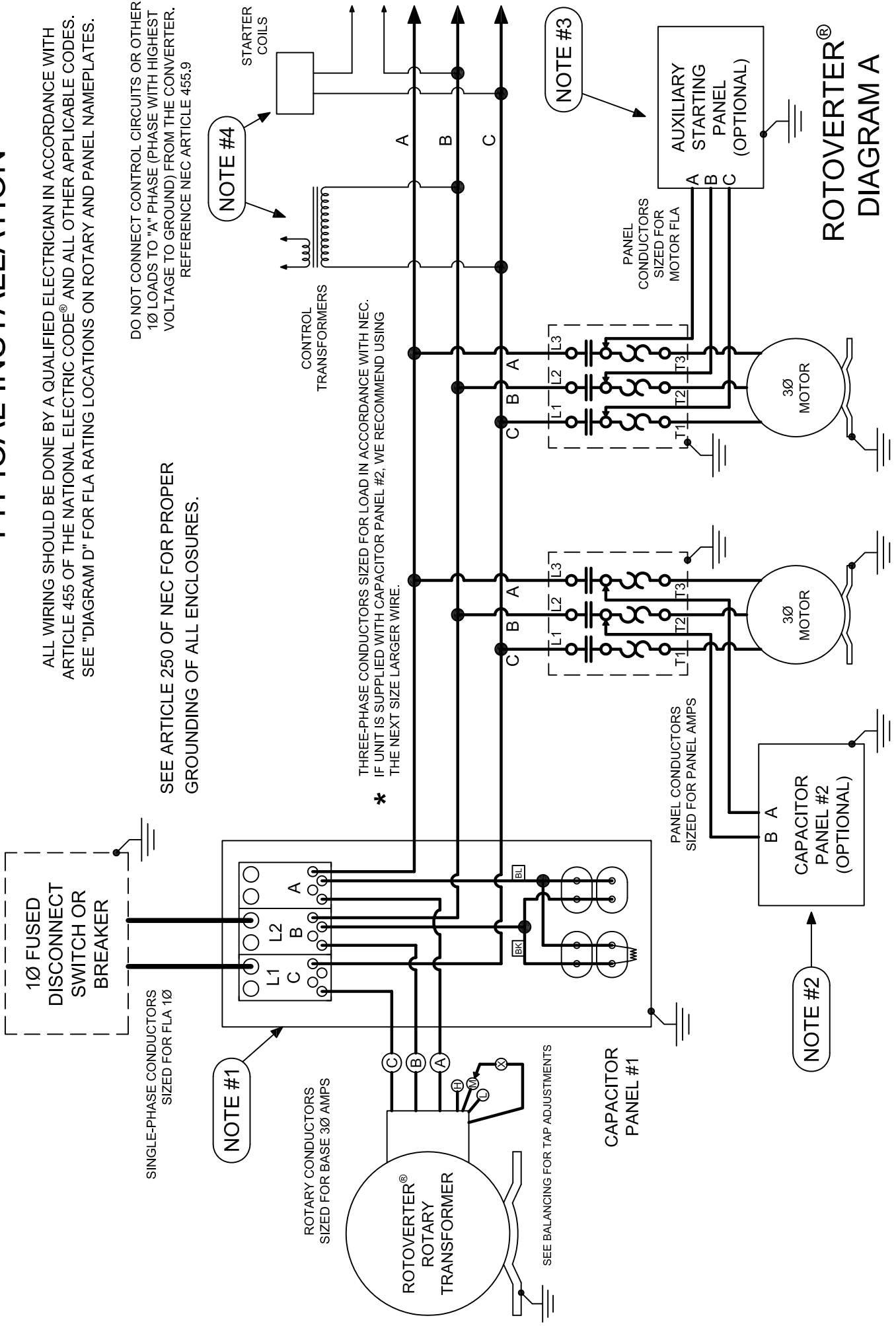

NOTE #1

NOTE #3

NOTE #2

ROTOVERTER®  
DIAGRAM A

## DIAGRAM B

7 LEAD ROTARY TRANSFORMERS ARE PREWIRED AT FACTORY FOR ONLY ONE VOLTAGE.  
 VERIFY THAT THE VOLTAGE RATING OF THE ROTARY BASE, CAPACITOR PANELS, AND SINGLE-PHASE SUPPLY ALL MATCH.  
 DAMAGE TO THE ROTOVERTER AND/OR LOAD EQUIPMENT MAY RESULT.

7 LEAD ROTARIES (A, B, C, X, L, M, H)

### 240 VOLT OPERATION (2C & 2D)

A → A                      Factory Tap Adjustment:  
 B → B                      X Connected to M Tap  
 C → C                      H & L Taps Insulated Separately

### 480 VOLT OPERATION (4C & 4D)

A → A                      Factory Tap Adjustment:  
 B → B                      X Connected to M Tap  
 C → C                      H & L Taps Insulated Separately

**WARNING!!**

ROTOVERTERS CAN BE OPERATED ONLY AT THEIR RATED VOLTAGE. BE SURE THE ROTARY BASE, PANEL, AND SINGLE-PHASE VOLTAGE RATINGS ALL MATCH. IF NOT, DAMAGE WILL OCCUR!

## DIAGRAM C

TYPICAL VOLTAGES FOR A 240 VOLT ROTOVERTER® (Double these values for a 480 volt unit)

VOLTAGE READINGS	IDLE CONDITIONS (no load on rotary converter)		FULL LOAD CONDITIONS (motor(s) up to speed)	
	APPROXIMATE VALUE	MEASURED VALUE	APPROXIMATE VALUE	MEASURED VALUE
"A" Phase to ground	235 volts	_____ volts	210 volts	_____ volts
"B" Phase to ground	120 volts	_____ volts	120 volts	_____ volts
"C" Phase to ground	120 volts	_____ volts	120 volts	_____ volts
"A" Phase to "B" Phase	280 volts	_____ volts	245 volts	_____ volts
"A" Phase to "C" Phase	235 volts	_____ volts	235 volts	_____ volts
"B" Phase to "C" Phase	240 volts	_____ volts	240 volts	_____ volts

If values vary considerably from the expected values, check the troubleshooting chart for instructions or call our Service Department at (217) 563-8333 for assistance. Note: If a three-phase output transformer is utilized, these values will be found on the input side of the transformer.

## DIAGRAM D



# TROUBLESHOOTING CHART

TYPE OF TROUBLE	CAUSE OF TROUBLE									
	SHORTED CONNECTION	IMPROPER SIZING 1Ø PROTECTION (SEE DIAGRAM A)	EXCESSIVE 1Ø VOLTAGE DROP (SEE STARTUP)	BAD CAPACITOR	MOTOR OVERLOADED	CAPACITORS MISCONNECTED (SEE DIAGRAM A, NOTE #1 & 2)	HIGH 1Ø VOLTAGE (SEE STARTUP)	EXCESSIVE CAPACITORS CONNECTED (SEE BALANCING)	INSUFFICIENT CAPACITORS CONNECTED (SEE BALANCING)	IMPROPER CONTROL CIRCUIT CONNECTION (SEE DIAGRAM A, NOTE #4)
TRIPS 1Ø PROTECTION WHEN STARTINGROTOVERTER	●	●	●			●				
ROTOVERTER DOESN'T START OR STARTS SLOWLY	●		●	●		●			●	
ROTOVERTER GETS EXCESSIVELY HOT						●	●	●		
TRIPS 1Ø PROTECTION WHEN STARTING LOAD MOTOR	●	●	●		●					
LOAD MOTOR DOESN'T START OR STARTS SLOWLY	●		●	●	●	●			●	
LOAD MOTOR STARTER DOESN'T ENGAGE OR CHATTERS			●							●
LOAD MOTOR SOMETIMES STARTS IN REVERSE						●				
PHASE CURRENTS HAVE CONSIDERABLE IMBALANCE				●	●	●		●	●	
EXCESSIVE AMPERAGES IN ALL MOTOR PHASES					●		●			
LOW A-B VOLTAGE WHEN LOADED				●	●	●			●	
HIGH A-B VOLTAGE WHEN LOADED								●		
HIGH A-B VOLTAGE WHEN IDLE						●	●	●		

## ROTARY TRANSFORMER LUBRICATION SCHEDULE

All units built prior to 1999 use lithium based motor bearing grease in their bearings. Units built in 2000 may have either a lithium based grease or a polyurea (Polyrex) grease. Units purchased after 2000 most likely have polyurea grease. The two types are compatible, so older units can have the newer polyurea type grease added to them and vice versa. The polyurea grease currently used is Polyrex EM (Exxon Mobile). The following greases should also be compatible: Texaco Polystar, Rykon Premium #2, Pennzoil Pen 2 Lube and Chevron SRI.

Below is a chart with lubrication information that is based upon the frame size of the rotary transformer. You can find the frame size of the rotary transformer on its nameplate. Use this information to determine the suggested lubrication intervals and amount of grease to add.

Note: Rotary transformers stored one year or longer should be lubricated before using. Seasonally used rotaries should be greased at the beginning of the season. Rotaries used in high dust, dirt, or moisture areas should be greased at one half the hours of operation shown on the chart.

Frame Size	Hours of Operation (Normal Operating Conditions)	Amount of Grease oz. (Grams) OR in <sup>3</sup> OR tsp.		
184 and smaller	12,000 hrs.	0.15 (3.9)	0.2	0.8
213 to 215	9,500 hrs.	0.19 (5.0)	0.3	1.0
254 to 256	9,500 hrs.	0.47 (12.5)	0.7	2.5
284 to 286	7,400 hrs	0.47 (12.5)	0.7	2.5
324 and larger	3,500 hrs	0.61 (17.0)	1.2	3.9

**Greasing Procedure:** Clean the grease fitting. Remove the purge plug located at the bottom of the bearing cap, if the unit has one. Rotaries can be greased while they are running, or when stopped, if the rotary's temperature is below 80° C. Add grease slowly. **DO NOT OVERGREASE!** Keep grease clean. Run the rotary (loaded or unloaded) for 20 minutes before replacing the purge plug.