

OPERATION & MAINTENANCE

VACUUM ASSISTED PUMP

QSF4X4

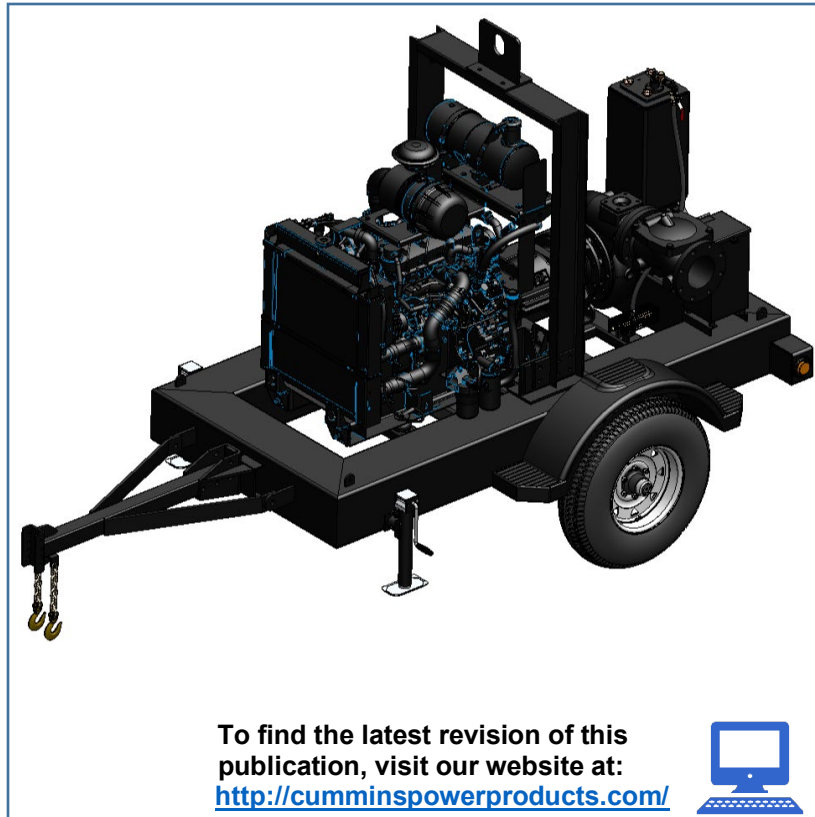



WARNING



CALIFORNIA – Proposition 65 Warning

Breathing diesel engine exhaust exposes you to chemicals known to the State of California to cause cancer and birth defects or other reproductive harm.

- Always start and operate the engine in a well-ventilated area.
- If in an enclosed area, vent the exhaust to the outside.
- Do not modify or tamper with the exhaust system.
- Do not idle the engine except as necessary.

For more information go to
www.P65warnings.ca.gov/diesel.

CALIFORNIA Proposition 65 Warning

Diesel engine exhaust and some of its constituents are known to the State of California to cause cancer, birth defects, and other reproductive harm.

Table of Contents

1. Introduction

Impeller	1
Wear Ring	1
Fuel System	1
Volute	1
Control Panel	1
Priming System	2
Air Separation	2
Training Checklist.....	3

2. Safety

Reporting Safety Defects.....	4
Safety Messages.....	5
Safety Symbols	5
General Safety	6
Pump Safety	6
Engine Safety.....	8
Fuel Safety.....	8
Battery Safety	9
Transporting Safety.....	9
Towing Safety	10
Environmental Safety/Decommissioning.....	11
Emission Control Label.....	12
Trailer Safety Guidelines	
Common Causes for Loss of Trailer	12
Trailer Towing Guidelines	12
Inoperable Brakes, Lights or Mirrors.....	13
Trailer Towing Tips	13
Trailer VIN Tag	14
Tow Vehicle.....	14
Suspension System	14
Brake Controller.....	14
Side View Mirrors.....	15
Heavy Duty Flasher	15
Electrical Connector.....	15
Emergency Flares & Triangle Reflectors	15
Safety Chains	15
Trailer Lighting and Braking Connector	15
Breakaway System	15
Jackstand	15
Coupler Types	15
Ball Hitch Coupler.....	15
Coupling the Trailer to the Tow Vehicle (Ball Coupler).....	16
Attaching Safety Chain	17
Breakaway Brake System	18
Breakaway Cable Surge Brake System.....	18
Connecting Trailer Lights	18
Uncoupling the Ball Hitch	18

Table of Contents

2. Safety

Trailer Safety Guidelines (continued)	
Pintle Hitch Coupler	19
Pintle Coupler and Pintle Hook.....	19
Coupling Trailer to Tow Vehicle (Pintle Coupler)	20
Tire Safety	
Unsafe Tires, Lug Nuts or Wheels.....	20
Determining Load Limit of Trailer	21
Determining Load Limit of Tow Vehicles.....	22
Tire Fundamentals.....	22
Uniform Tire Quality Grading Standards (UTQGS)	24
Tire Safety Tips	24
Tire Repair.....	24
Replacing Worn or Damaged Tires	25
Wheel Rims	25
Wheels, Bearings and Lug Nuts	25
Lug Nut Torque Requirements.....	25
Lights and Signals	26

3. Operation

Pre-operation Checklist	27
Inspection and Setup	
Engine Oil.....	28
Checking Engine Oil	28
Fuel Check	28
Battery Cable Connection	29
Pump Placement	29
Suction/Discharge Hose Connections	29
Priming System	31
Installation	31
Pre-start Up	31
Start-up & Operation.....	31
Shutdown	32
Pump Inspection after Use.....	32
Storage.....	32

4. Specifications

QSF6X6 Pump Specifications.....	33
Pump Performance Curve	34
Engine Specifications	35
Trailer Specifications	35
Auto Start/Stop Control Panel.....	36
Features	36
Manual Operation	36
Automatic Operation	36

Table of Contents

4. Specifications (continued)

Auto Start/Stop Control Panel (continued)	
Automatic Throttle.....	36
Communications.....	36
Technical Specifications.....	37

5. Application

Pumping Application.....	38
Towing Application.....	39

6. Maintenance

Pump Maintenance.....	40
Dry Pump Vacuum Test.....	40
Pump Flushing.....	41
Testing the Venturi Nozzle.....	42
Checking Operation of Float Assembly.....	42
Engine Maintenance.....	44
Maintenance Guidelines - Overview.....	44
Maintenance Schedule.....	44
Maintenance Procedures at Daily Interval.....	44
Maintenance Procedures at 250 Hours or 3 Months.....	44
Maintenance Procedures at 500 Hours or 6 Months.....	45
Maintenance Procedures at 1000 Hours or 1 Year.....	45
Maintenance Procedures at 2000 Hours or 2 Years.....	45
Daily Maintenance Procedures – Overview	
General Information.....	45
System Operation Report.....	45
Unusual System Noise.....	46
Crankcase Breather Tube.....	46
Lubricating Oil Level.....	47
Fuel-Water Separator.....	47
Preparatory Steps.....	48
Drain.....	49
Remove.....	49
Install.....	50
Finishing Steps.....	50
Prime.....	51
Fan, Cooling.....	52
Coolant Level.....	53
Air Intake Piping.....	54
Air Cleaner Restriction.....	54
Dust Ejection Valve.....	55
Drive Belts.....	55

Table of Contents

6. Maintenance (continued)

Maintenance Procedures at 250 Hours or 3 Months	
Overview – General Information.....	56
Lubricating Oil and Filters – Drain	56
Radiator Hoses	57
Charge-Air Cooler.....	57
Charge-Air Piping	57
Air Intake Piping.....	58
Maintenance Procedures at 500 Hours or 6 Months	
Overview – General Information.....	58
Fuel-Water Separator – General Information.....	58
Preparatory Steps	59
Drain	60
Install	61
Finishing Steps.....	61
Prime	62
Fuel Filter (Cartridge Type) – General Information.....	63
Preparatory Steps	63
Remove	64
Finishing Steps.....	65
Prime	65
Lubricating Oil and Filters	
Drain	66
Remove	67
Install	67
Fill.....	68
Radiator Pressure Cap	
General Information.....	69
Inspect for Reuse	69
Engine Coolant Antifreeze	70
Batteries	70
Battery Cables and Connections	71
Maintenance Procedures at 1000 Hours or 1 Year	
Overview – General Information.....	73
Fan Hub, Belt Driven.....	73
Cooling Fan Belt Tensioner.....	73
Preparatory Steps	74
Remove	75
Clean and Inspect for Reuse	75
Install	76
Finishing Steps.....	76
Maintenance Procedures at 2000 Hours or 2 Years	
Overview – General Information.....	76
Overhead Set – Adjust.....	76
Cooling System – General Information.....	77
Maintenance Check.....	78
Drain	78
Flush.....	79
Fill.....	81

Table of Contents

6. Maintenance (continued)

Additional Engine Service Literature	
General Information	82
Service Literature Ordering Location.....	83
Service Assistance – General Information	83
Routine Service and Parts.....	83
Ordering the Customized Parts Catalog	
Ordering by Telephone	83
Ordering On-line	83
Trailer Maintenance	
The Importance of Maintenance.....	84
Preventive Maintenance Safety.....	84
Tires	84
Brakes (When Equipped)	
Electric Brakes	84
Hydraulic Surge Brakes.....	84
Lights (When Equipped).....	84
Jackstand	84
Miscellaneous.....	84
Trailer Brakes	85
Electric Brakes	85
Breakaway Brakes	
Breakaway Battery	85
Breakaway Switch.....	85
Tow Vehicle Operated Electric Brakes	86
Adjustable Channel.....	86
Wheel Bearings	87
Wheel Hub Adjustment	87

7. Troubleshooting

Pump Troubleshooting	89
Control Panel Troubleshooting	90
Engine Troubleshooting	
Troubleshooting Procedures and Techniques.....	91
General Safety Instructions.....	91
Work Environment	91
Best Practices.....	91
Personal Protective Equipment	91
Engine Difficult to Start or Will Not Start (Exhaust Smoke).....	93
Engine Difficult to Start or Will Not Start (No Exhaust Smoke)	95
Engine Power Output Low	97
Engine Runs Rough at Idle	99
Engine Shuts Off Unexpectedly or Dies During Deceleration	101
Engine Starts but Will Not Keep Running	102

Table of Contents

8. Drawings

Control Panel Wiring Diagram	103
Layout Drawing	104
Label Drawing – Driver’s Side Perspective	105
Label Drawing – Passenger Side Perspective.....	106
Bill of Materials – Labels	107
QSF6X6 Parts and Assembly	108
Bill of Material – QSF6X6 Parts and Assembly	109
Air Separation Chamber Assembly	111
Bill of Material – Air Separation Chamber Assembly.....	112
Trailer Assembly	114
Bill of Material – Trailer Assembly	115
Engine Views	
Front View	117
Left Side View.....	118
Rear View.....	119
Right Side View	120
Top View	121

The QSF series pumps are automatic prime-assist pumps that can handle dewatering, sewer/stream bypass, and water transfer applications.

The QSF series pump uses a compressor & venturi to remove air from the suction line. This innovative priming system prevents blow-by of sewage, effluent and waste from discharging onto the ground. This system offers mid-range air handling capabilities for quick priming.

QSF series pumps use an integral engine-mounted compressor and venturi eductor system to efficiently remove large volumes of air quickly to obtain the priming necessary for these special applications. QSF series pumps are very useful when you have to move a lot of water fast.

Impeller

The impeller used on the QSF series pumps has a patented design to eliminate cavitation. It is a closed 2-bladespiral, smooth flow, open, non-clog impeller, designed to handle up to 3 inch solids.

Fuel System

The QSF series pump has a fuel tank that is integrated into the trailer. This fuel tank provides the pump with the capability for continuous running for long-term jobs. There are two corner fuel drains to allow for easy draining and cleaning.

Fuel tank capacity is 100 useable gallons (378 liters) for the QSF series pumps with a run time of 40 hours @1800 rpm or 34 hours @2,400 rpm.

Volute

The ductile iron pump volute has an external inspection/clean-out cover to inspect or clear the impeller. The pump shaft bearings and mechanical seal are grease lubricated for low maintenance and ease of relubrication.

Control Panel

Auto start / stop control panel with OLED display for visibility in bright sunlight with traditional key start operation. Features include:

- Manual speed control with programmable minimum and maximum speeds visible on display
- Engine information display – oil pressure, coolant temperature, engine speed (rpm), battery voltage, fuel level in primary tank, and running hours.
- Displays engine diagnostic fault codes
- Programmable maintenance alerts that will appear on the display
- Prestart audible alarm in panel with an amber strobe light that will activate when the auto float engages.
- Failure to start audible alarm, plus additional connection for primary auto start/stop float control
- Connection for automatic operation using a level or pressure transducer with float Backup and high-level alarm.
- Programmable weekly exercise timer
- Programmable time start based on ambient temperature
- Also has input that can be used for low coolant, and low oil level
- Electrical component rating IP67
- Telemetry compatible

Priming System

The exclusive ENVIROPRIME® dry-priming system works in conjunction with the Cummins 6.5 cfm engine mounted compressor/venturi priming system to prevent blow-by, such as sewage and waste, from discharging onto the ground. The system works automatically, evacuating the air from the suction line during startup, as well as any air or gases introduced into the suction line during the pumping process.

Air Separation

Easily removable top on the priming chamber is secured with bronze wrenches for easy removal of the float assembly. The float assembly includes a stainless float with a stainless rod, nitrile rubber valve seat and stainless hardware. A manual ball valve is located on the top of the chamber that provides protection in positive suction head conditions.

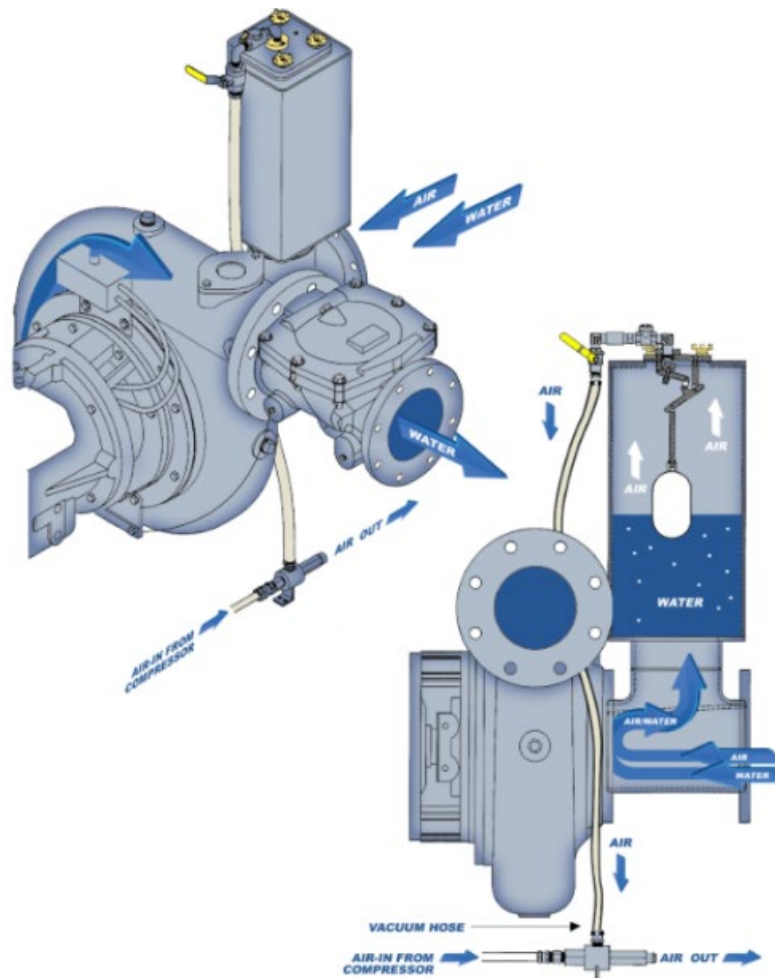

Figure 1-A. Priming System

Training Checklist

This checklist outlines the minimum requirements for machine maintenance and operation. Detach it and make copies for use. Use this checklist whenever a new operator is to be trained or it can be used as a review for more experienced operators.

Training Checklist			
No.	Description	Completed?	Date
1	Read the operation manual completely		
2	Machine layout, location of components, pre-start checklist of engine		
3	Fuel system, refueling procedure		
4	Operation of controls (machine not running)		
5	Safety controls, safety stop switch operation		
6	Emergency stop procedures		
7	Startup of machine, pre-heat, engine choke		
8	Shutdown of machine		
9	Lifting of machine (lifting bale)		
10	Machine transport and storage		

Reporting Safety Defects

If you believe that your vehicle has a defect that could cause a crash or could cause injury or death, you should immediately inform the National Highway Traffic Safety Administration (NHTSA) in addition to notifying your nearest Cummins distributor.

If NHTSA receives similar complaints, it may open an investigation, and if it finds that a safety defect exists in a group of vehicles, it may order a recall and remedy campaign.

To contact NHTSA, you may either call the Vehicle Safety Hotline toll-free at 1-888-327-4236 (TTY: 1-800-424-9153), go to <http://www.nhtsa.dot.gov>; or write to:

Administrator
NHTSA
1200 New Jersey Avenue S.E.
Washington, DC 20590

You can also obtain information about motor vehicle safety from <http://www.safercar.gov>.

Do not operate or service the equipment before reading the entire manual. Safety precautions should always be followed when operating this equipment. Failure to read and understand the safety messages and operating instructions could result in injury to yourself and others.





Safety Messages

The four safety messages shown below will inform you about potential hazards that could injure you or others. The safety messages specifically address the level of exposure to the operator and are preceded by one of four words: **DANGER**, **WARNING**, **CAUTION** or **NOTICE**.

Safety Symbols







 **DANGER**
Indicates a hazardous situation which, if not avoided, **will** result in **death**, or **serious injury**.

 **WARNING**
Indicates a hazardous situation which, if not avoided, **could** result in **death**, or **serious injury**.

 **CAUTION**
Indicates a hazardous situation which, if not avoided, **could** result in **minor** or **moderate injury**.

NOTICE
Addresses practices not related to personal injury

Potential hazards associated with the operation of this equipment will be referenced with hazard symbols which may appear throughout this manual in conjunction with safety messages.

Symbol	Safety Hazard
	Lethal exhaust gas hazards
	Explosive fuel hazards
	Burn hazards
	Respiratory hazards
	Accidental starting hazards
	Eye and hearing hazards

General Safety



CAUTION

Never operate this equipment without proper protective clothing, shatterproof glasses, respiratory protection, hearing protection, steel-toed boots, and other protective devices required by the job or local regulations. Lack of proper protective equipment can lead to personal injury

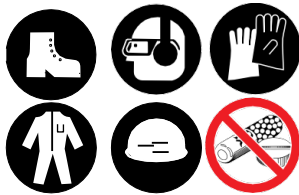

CAUTION

Never operate this equipment when not feeling well due to fatigue, illness or when under medication. These conditions can cause accidents.



CAUTION

Never operate this equipment under the influence of drugs or alcohol. A person under the influence of any of these factors may experience a slow reaction time, impaired coordination, and lack of judgment.

NOTICE

This equipment should only be operated by trained and qualified personnel 18 years of age or older.



NOTICE

Whenever necessary, replace nameplate, operation and safety decals when they become difficult to read.

NOTICE

Manufacturer does not assume responsibility for any accident due to equipment modifications. Unauthorized equipment modifications will void all warranties.

NOTICE

Never use accessories or attachments that are not recommended by Cummins, Inc. for this equipment. Damage to the equipment and/or injury to the user may result.

NOTICE

Always know the location of the nearest fire extinguisher.

NOTICE

Always know the location of the nearest first aid kit.

NOTICE

Always know the location of the nearest phone or keep a phone on the job site. Also, know the phone numbers of the nearest ambulance, doctor and fire department. This information will be useful in the case of an emergency.



Pump Safety



DANGER

Never pump volatile, explosive, flammable or low flash point liquids. These liquids could ignite or explode.



DANGER

The engine fuel exhaust gases contain poisonous carbon monoxide. This gas is colorless and odorless, and can cause death if inhaled in sufficient quantity.



DANGER

The engine of this equipment requires an adequate free flow of cooling air. **Never** operate this equipment in any enclosed or narrow area where free flow of air is restricted. If the air flow is restricted it will cause injury to people and property and serious damage to the equipment or engine.

! DANGER

Never operate the equipment in an explosive atmosphere or near combustible materials. An explosion or fire could cause severe **bodily harm or even death**.

! WARNING

Never pump corrosive chemicals or water containing toxic substances. The liquids could create serious health and environmental hazards. Contact local authorities for assistance.

! WARNING

Never open the priming plug when pump is hot. Hot water inside could be pressurized. Allow pump to cool to the touch before loosening plug. The possibility exists of scalding, resulting in severe bodily harm.

! WARNING

Never operate the pump with a closed discharge hose. The liquid could reach boiling temperatures, build pressure, and cause the casing or hose to rupture or explode.

! WARNING

Never run the pump dry. Mechanical parts will overheat and could seize which can cause equipment failure and threat to personal safety.

! WARNING

Never disconnect any emergency or safety devices. These devices are intended for operator safety. Disconnection of these devices can cause severe injury, bodily harm or even death. Disconnection of any of these devices will void all warranties.

! CAUTION

Never lubricate components or attempt service on a running machine. Serious injury is possible due to entanglement with rotating parts.

! CAUTION

Never block or restrict flow from discharge hose. Remove kinks from discharge line before starting pump. Operation with a blocked discharge line can cause water inside the pump to overheat and build up pressure.

! CAUTION

Never allow the suction line to become clogged or mired in mud. This condition could cause water inside the pump to overheat creating a rupture or explosion.

NOTICE

Prolonged failure to maintain water inside the pump casing will cause severe damage to the pump and mechanical seal.

NOTICE

Freezing Weather

- In Winter, drain water from the pump casing to prevent freezing.
- If freezing of the pump is evident or suspected, stop the engine immediately or mechanical damage is possible.

NOTICE

Never start the pump with the clean-out cover removed. The rotating impeller inside the pump can cut or sever objects caught in it. Before starting the pump, check that the clean-out cover is securely fastened.

NOTICE

Always keep the pump in proper running condition. Otherwise, mechanical deficiencies could develop.

NOTICE

Always make sure the pump is on level ground before use and wheels are secured with chock blocks.

NOTICE

Fix damage to pump and replace any broken parts immediately to prevent further damage.

NOTICE

Always store equipment properly when it is not being used. Equipment should be stored in a clean, dry location out of the reach of children and unauthorized personnel.

NOTICE

Always make sure that all suction hose connections are tightened securely.

2. SAFETY

Operation and Maintenance

NOTICE

Never operate the pump at an excessive angle of inclination. Lubricating oil levels may not properly lubricate parts.

NOTICE

Never attempt suction lifts over 7.62 meters (25 ft). The pump may vibrate and become unstable.

NOTICE

Keep suction lift to a minimum and support all hoses and piping as needed.

NOTICE

Never pump sand, abrasive liquids, or solids. Mechanical damage can occur to the impeller and volute.

NOTICE

Never lift the pump with suction and discharge hoses attached.

Engine Safety



WARNING

Do Not place hands or fingers inside compartment when engine is running.



WARNING

Never operate the engine with heat shields or guards removed.



WARNING

Do Not remove the engine oil drain plug while the engine is hot. Hot oil will gush out of the oil sump and severely scald any persons in the general area of the pump.



CAUTION

Never touch the hot exhaust manifold, muffler or cylinders. Severe burns will occur. Allow these parts to cool before servicing equipment.



NOTICE

Never run an engine without an air filter or with a dirty air filter. Severe engine damage may occur. Service the air filter frequently to prevent engine malfunction.

NOTICE

Never tamper with the factory settings of the engine or engine governor. Damage to the engine or equipment can result if operating in speed ranges above the maximum allowable.

Fuel Safety



DANGER

Do Not start the engine near spilled fuel or combustible liquids. Fuel is extremely flammable and its vapors can cause an explosion if ignited.



DANGER

Always refuel in a well-ventilated area, away from sparks and open flames. Fuel is extremely flammable and its vapors can cause an explosion if ignited.



DANGER

Always use extreme caution when working with flammable liquids. Their vapors can cause a fire or explosion if ignited.



DANGER

Do Not fill the fuel tank while the engine is running or hot. Spilling fuel on a hot part could ignite the fuel.



DANGER

Do Not overfill the tank since spilled fuel could ignite if it comes in contact with hot engine parts or sparks from the ignition system.



DANGER

Store fuel in appropriate containers, in well-ventilated areas and away from sparks and flames. Vapors leaking from a fuel container can ignite.



DANGER

Never use fuel as a cleaning agent. Fuel is more volatile and easier to ignite than cleaning fluids.



DANGER

DO NOT smoke around or near the equipment. Fire or explosion could result from fuel vapors or if fuel is spilled on a hot engine.



! DANGER

Diesel fuel will expand if left unattended in the hot sunlight. For a 100 gallon tank, this expansion of fuel is approximately 0.5 gallons with an increase of 10 degrees Fahrenheit. The standard fuel neck will hold approximately 0.25 gallons from the top of the screen to the top of the filler neck. It is therefore not recommended to fill the tank above the screen in the filler neck, and in areas where the temperature change is high over the course of the day; it is recommended to leave enough room in the tank for the corresponding expansion.

Battery Safety (Electric Start Only)

! DANGER

Do Not drop the battery. There is a possibility that the battery will explode.

! DANGER

Do Not expose the battery to open flames, sparks, cigarettes, and so on. The battery contains combustible gases and liquids. If these gases and liquids come in contact with a flame or spark, an explosion could occur.



! WARNING

Always wear safety glasses when handling the battery to avoid eye irritation. The battery contains acids that can cause injury to the eyes and skin.



! WARNING

Use well-insulated gloves when picking up the battery. The battery contains acids that can cause injury to the skin.

! WARNING

Always keep the battery charged. If the battery is not charged, combustible gases, which could be ignited, will build up.

! WARNING

Do Not charge battery if frozen. Battery can explode. When frozen, warm the battery to at least 61°F (16°C).

! WARNING

Always recharge the battery in a well-ventilated environment to avoid the risk of a dangerous concentration of combustible gases.

! WARNING

If the battery liquid (dilute sulfuric acid) comes into contact with **clothing or skin**, rinse skin or clothing immediately with plenty of water. Severe skin damage is possible.



! WARNING

If the battery liquid (dilute sulfuric acid) comes into contact with eyes, rinse eyes immediately with plenty of water and contact the nearest doctor or hospital to seek medical attention. Severe damage to the eyes is possible.

! CAUTION

Always disconnect the **Negative battery terminal** before performing service on the equipment.

! CAUTION

Always keep battery cables in working condition. Repair or replace all worn cables.

Transporting Safety

! CAUTION

Never allow any person or animal to stand underneath the equipment while lifting.

NOTICE

Before lifting, make sure that the equipment parts are not damaged and screws are not loose or missing.

NOTICE

Always insert forklift forks into pockets (if applicable) as far as possible when lifting pump.

NOTICE

Always shut down engine before transporting.

NOTICE

Never lift the equipment while the engine is running.

NOTICE

Tighten fuel cap securely and close fuel cock to prevent fuel from leaking.

NOTICE

Use one-point suspension hook and lift straight up.

NOTICE

Do Not lift machine to unnecessary heights.

NOTICE

Always tie down equipment during transport by securing the equipment with rope or straps.

Towing Safety



CAUTION

Check with your local county or state safety towing regulations, in addition to reviewing any applicable National Towing Regulations, before towing your equipment. Failure to do so can lead to unsafe towing and/or potential legal consequences.



CAUTION

Refer to the **TRAILER SAFETY GUIDELINES** section in this manual for additional safety information. Failure to do so could increase the possibility of accidents.



CAUTION

To reduce the possibility of an accident while transporting the equipment on public roads, **ALWAYS** make sure the trailer that supports the equipment and towing vehicle is mechanically sound and in good operating condition.



CAUTION

Always shut down the engine before transporting. Engines are designed for stationary operation. Fuel spills could be one result of moving while in operation.



CAUTION

Make sure the hitch and coupling of the towing vehicle are rated equal to, or greater than the trailer "gross vehicle weight rating." A trailer uncoupling from the towing vehicle can lead to a serious accident.



CAUTION

Always inspect the hitch and coupling for wear. **Never** tow a trailer with defective hitches, couplings, chains, etc. Damaged or defective equipment can cause an accident.



CAUTION

Check the tire air pressure on both towing vehicle and trailer. Trailer tires should be inflated to 50 psi cold. Also check the tire tread wear on both vehicles. Sudden tire failure can cause an accident.



CAUTION

Always make sure the trailer is equipped with a **safety chain**. Required in most states, a safety chain acts as a backup if your trailer becomes disconnected from your tow vehicle.



CAUTION

Always properly attach trailer's safety chains to towing vehicle. Towing adds a measure of responsibility to driving. Making sure everything safely connects is the first part of that. Serious accidents can occur if safety chains are not attached properly.



CAUTION

DOT requirements include the following:

- Connect and test electric brake operation.
- Secure portable power cables in cable tray with the wraps.

Failure to adhere to these requirements is a possible cause of accidents.



CAUTION

Maximum speed for highway towing is 55 MPH unless posted otherwise. Recommended off-road towing is not to exceed 15 MPH or less depending on type of terrain. The maximum (controllable) speed is the speed at which an outside factor, maybe a gust of wind or the need to make a sudden maneuver, will cause a vehicle to go out of its operator's control.



CAUTION

Avoid sudden stops and starts. This can cause skidding, or jack-knifing. Smooth, gradual starts and stops will improve towing.

CAUTION
 Avoid sharp turns to prevent rolling.

CAUTION
 Trailers should be adjusted to a level position at all times when towing. This is to prevent uneven tire wear, as well as sway or turbulence during the drive.

CAUTION
 Raise and lock trailer wheel stand in up position when towing. It could come in contact with the ground if left down and be torn off and thrown into traffic.

CAUTION
 Place chock blocks underneath wheel to prevent rolling while parked. Chocking is done to prevent trailers from unintentionally moving, like rolling or overturning, while workers are loading, unloading, hitching, unhitching or servicing the unit.

CAUTION
 Place support blocks underneath the trailer's bumper to prevent tipping while parked.

CAUTION
 Use the trailer's swivel jack to adjust the trailer height to a level position while parked. Beware of pinch points, and crush potential from the foot plate.

Environmental Safety/Decommissioning

Decommissioning is a controlled process used to safely retire a piece of equipment that is no longer serviceable. If the equipment poses an unacceptable or unrepairable safety risk due to wear or damage or is no longer cost effective to maintain (beyond life-cycle reliability) and is to be decommissioned (demolition and dismantlement), be sure to follow the rules below:

NOTICE
Do Not pour waste or oil directly onto the ground, down a drain or into a water source.

NOTICE
 Contact your county's Department of Public Works or recycling agency in your area and arrange for proper disposal of any electrical components, waste or oil associated with this equipment.



NOTICE
 When the life cycle of this equipment is over, remove battery and bring to appropriate facility for lead reclamation. Use safety precautions when handling batteries that contain sulfuric acid.

NOTICE
 When the life cycle of this equipment is over, it is recommended that the pump and all other metal parts be sent to a recycling center.

Metal recycling involves the collection of metal from discarded products and its transformation into raw materials to use in manufacturing a new product.

Recyclers and manufacturers alike promote the process of recycling metal. Using a metal recycling center promotes energy cost savings.

NOTICE
 The diesel engine used in this equipment has been designed to reduce harmful levels of carbon monoxide (CO), hydrocarbons (HC) and nitrogen oxides (NOx) contained in diesel engine exhaust emissions.

This engine has been certified to meet US EPA evaporative emissions requirements in the installed configuration.

Attempting to modify or make adjustments to the engine emission system by unauthorized personnel without proper training could damage the equipment or create unsafe condition.

Additionally, modifying the fuel system may worsen evaporative emissions, resulting in fines or other penalties.

Emission Control Label

The emission control label is an integral part of the emission system and is strictly controlled by regulations.

The label must remain with the engine for its entire life.

If a replacement emission label is needed, please contact your authorized engine distributor.

Trailer Safety Guidelines

The following guidelines are intended to assist the operator in the operation and handling of a trailer.

Safety precautions should be followed at all times when operating a trailer. Failure to read, understand and follow the safety guidelines could result in injury to yourself and others. Loss of control of the trailer or tow vehicle can result in death or serious injury.

Common Causes for Loss of Trailer

- Driving too fast for the conditions (maximum speed when towing a trailer is 55 mph).
- Overloading the trailer or loading the trailer unevenly.
- Trailer improperly coupled to the hitch.
- No braking on trailer.
- Not maintaining proper tire pressure.
- Not keeping lug nuts tight.
- Not properly maintaining the trailer structure.
- Ensure machine is towed level to tow vehicle.

Trailer Towing Guidelines

- Recheck the load tiedowns to make sure the load will not shift during towing.
- Before towing, check coupling, safety chain, safety brake, tires, wheels and lights.
- Check the lug nuts or bolts for tightness.
- Check coupler tightness after towing 50 miles.
- Use your mirrors to verify that you have room to change lanes or pull into traffic.
- Use your turn signals well in advance. Allow plenty of stopping space for your trailer and tow vehicle.

- Allow plenty of stopping space for your trailer and tow vehicle.
- **Do Not** drive so fast that the trailer begins to sway due to speed.
- Allow plenty of room for passing. A rule of thumb is that the passing distance with a trailer is 4 times the passing distance without the trailer.
- Shift your automatic transmission into a lower gear for city driving.
- **Always** use lower gears for climbing and descending grades.
- **Do Not** ride the brakes while descending grades, they may get so hot that they stop working. Then you will potentially have a runaway tow vehicle and trailer.
- To conserve fuel, don't use full throttle to climb a hill. Instead, build speed on the approach.
- Slow down for bumps in the road. Take your foot off the brake when crossing the bump.
- **Do Not** brake while in a curve unless absolutely necessary. Instead, slow down before you enter the curve and power through the curve. This way, the towing vehicle remains in charge.
- **Do Not** apply the brakes to correct extreme trailer swaying. Continued pulling of the trailer, and even slight acceleration, will provide a stabilizing force.
- Anticipate the trailer "swaying." Swaying is the trailer reaction to the air pressure wave caused by passing trucks and buses. Continued pulling of the trailer provides a stabilizing force to correct swaying. **Do Not** apply the brakes to correct trailer swaying.
- Use lower gear when driving down steep or long grades. Use the engine and transmission as a brake. **Do Not** ride the brakes, as they can overheat and become ineffective.
- Be aware of your trailer height, especially when approaching roofed areas and around trees.
- Make regular stops, about once each hour. Confirm that:
 - Coupler is secure to the hitch and is locked.
 - Electrical connectors are secure.
 - There is appropriate slack in the safety chains.
 - There is appropriate slack in the breakaway switch pullpin cable.
 - Tires are not visibly low on pressure.

Inoperable Brakes, Lights or Mirrors

Be sure that the brakes and all of the lights on your trailer are functioning properly before towing your trailer. Check the trailer taillights by turning on your tow vehicle headlights. Check the trailer brake lights by having someone step on the tow vehicle brake pedal while you look at trailer lights. Do the same thing to check the turn signal lights. See Trailer Wiring Diagram section in this manual.

Standard mirrors usually do not provide adequate visibility for viewing traffic to the sides and rear of a towed trailer. You must provide mirrors that allow you to safely observe approaching traffic.



WARNING

Improper electrical connection between the tow vehicle and the trailer will result in inoperable lights and can lead to collision.

Before each tow, check that the tail lights, brake lights and turn signals work.

Trailer Towing Tips

Driving a vehicle with a trailer in tow is vastly different from driving the same vehicle without a trailer in tow. Acceleration, maneuverability and braking are all diminished with a trailer in tow.

It takes longer to get up to speed, you need more room to turn and pass, and more distance to stop when towing a trailer. You will need to spend time adjusting to the different feel and maneuverability of the tow vehicle with a loaded trailer.

Because of the significant differences in all aspects of maneuverability when towing a trailer, the hazards and risks of injury are also much greater than when driving without a trailer. You are responsible for keeping your vehicle and trailer in control, and for all the damage that is caused if you lose control of your vehicle and trailer.

As you did when learning to drive an automobile, find an open area with little or no traffic for your first practice trailering. Of course, before you start towing the trailer, you must follow all of the instructions for inspection, testing, loading and coupling. Also, before you start towing, adjust the mirrors so you can see the trailer as well as the area to the rear of it.

Drive slowly at first, 5 mph or so, and turn the wheel to get the feel of how the tow vehicle and trailer combination responds. Next, make some right and left hand turns. Watch in your side mirrors to see how the trailer follows the tow vehicle. Turning with a trailer attached requires more room.

Stop the rig a few times from speeds no greater than 10 mph. If your trailer is equipped with brakes, try using different combinations of trailer brake and tow vehicle brake. Note the effect that the trailer brakes have when they are the only brakes used. When properly adjusted, the trailer brakes will come on just before the tow vehicle brakes.

It will take practice to learn how to back up a tow vehicle with a trailer attached. Take it slow. Before backing up, get out of the tow vehicle and look behind the trailer to make sure that there are no obstacles.

Some drivers place their hands at the bottom of the steering wheel, and while the tow vehicle is in reverse, “think” of the hands as being on the top of the wheel. When the hands move to the right (**counterclockwise**, as you would do to turn the tow vehicle to the left when moving forward), the rear of the trailer moves to the right. Conversely, rotating the steering wheel **clockwise** with your hands at the bottom of the wheel will move the rear of the trailer to the left while backing up.

If you are towing a bumper hitch rig, be careful not to allow the trailer to turn too much because it will hit the rear of the tow vehicle. To straighten the rig, either pull forward or turn the steering wheel in the opposite direction.

Trailer VIN Tag

Fig 2-A below is a sample of the Vehicle Identification Number (VIN) Tag which is typically located on the left front of the trailer. See Figure 2-B for location.



Figure 2-A. Vehicle VIN Tag

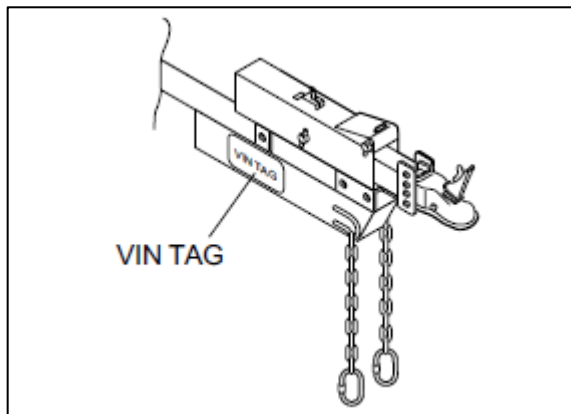

Figure 2-B. VIN Tag Location

The trailer VIN Tag contains the following critical safety information for the use of your trailer:

GAWR: The maximum gross weight that an axle can support. It is the lowest of axle, wheel, or tire rating.

Usually, the tire or wheel rating is lower than the axle rating, and determines GAWR.

GVWR: The maximum allowable gross weight of the trailer and its contents. The gross weight of the trailer includes the weight of the trailer and all of the items within it. GVWR is sometimes referred to as GTWR (Gross Trailer Weight Rating), or MGTW (Maximum Gross Trailer Weight). GVWR, GTWR and MGTW are all the same rating.

The sum total of the GAWR for all trailer axles may be less than the GVWR for the trailer, because some of the trailer load is to be carried by the tow vehicle, rather than by the trailer axle(s). The total weight of the cargo and trailer must not exceed the GVWR, and the load on an axle must not exceed its GAWR.

PSIC: The tire pressure (psi) measured when cold.

VIN: The Vehicle Identification Number.

EMPTY WEIGHT: Some information that comes with the trailer (such as the Manufacturer's Statement of Origin) is not a reliable source for "empty" or "net" weight. The shipping documents list average or standard weights and your trailer may be equipped with options.

To determine the "empty" or "net" weight of your trailer, weigh it on an axle scale. To find the weight of the trailer using an axle scale, you must know the axle weights of your tow vehicle without the trailer coupled. Some of the trailer weight will be transferred from the trailer to the tow vehicle axles, and an axle scale weighs all axles, including the tow vehicle axles.

Tow Vehicle

The towing hitch attached to your tow vehicle must have a capacity equal to or greater than the load rating of the trailer you intend to tow. The hitch capacity must also be matched to the tow vehicle capacity. Your vehicle dealer can provide and install the proper hitch on your tow vehicle.

Suspension System

Sway bars, shock absorbers, heavy duty springs, heavy duty tires and other suspension components may be required to sufficiently tow the trailer and pump.

Brake Controller

For trailers equipped with electric brakes, the electric brake controller is part of the tow vehicle and is essential in the operation of the electric brakes on the trailer. The brake controller is not the same as the safety breakaway brake system that may be equipped on the trailer.

Side View Mirrors

The size of the trailer that is being towed and your state law regulations determine the size of the mirrors. However, some states prohibit extended mirrors on a tow vehicle, except while a trailer is actually being towed. In this situation, detachable extended mirrors are necessary. Check with your dealer or the appropriate state agency for mirror requirements.

Heavy Duty Flasher

A Heavy Duty Flasher is an electrical component that may be required when your trailer turn signal lights are attached to the tow vehicle flasher circuit.

Electrical Connector

An Electrical Connector connects the light and brake systems on the trailer to the light and brake controls on the towing vehicle.

Emergency Flares & Triangle Reflectors

It is wise to carry these warning devices even if you are not towing a trailer. It is particularly important to have these when towing a trailer because the hazard flashers of your towing vehicle will not operate for as long a period of time when the battery is running both the trailer lights and tow vehicle lights.

Safety Chains

If the coupler connection comes loose, the safety chains can keep the trailer attached to the tow vehicle. With properly rigged safety chains, it is possible to keep the tongue of the trailer from digging into the road pavement, even if the coupler-to-hitch connection comes apart.

Trailer Lighting and Braking Connector

A device that connects electrical power from the tow vehicle to the trailer. Electricity is used to turn on brake lights, running lights, and turn signals as required. In addition, if your trailer has a separate braking system, the electrical connector will also supply power to the brakes from the tow vehicle.

Breakaway System

If the trailer coupler connection comes loose, the breakaway system can actuate emergency hydraulic brakes depending on the type of actuator on the trailer. The breakaway cable must be rigged to the tow vehicle with appropriate slack that will activate the system if the coupler connection comes loose.

Jackstand

A device on the trailer that is used to raise and lower the coupler. The jack is sometimes called the “landing gear” or the “tongue jack”.

Coupler Types

Two types of coupler used with the trailer are discussed below.

- Ball Hitch Coupler
- Pintle Eye Coupler

Ball Hitch Coupler

A ball hitch coupler (Figure 2-C) connects to a ball that is located on or under the rear bumper of tow vehicle. This system of coupling a trailer to a tow vehicle is sometimes referred to as “bumper pull.”

A ball hitch trailer may be fitted with a tongue jack that can raise and lower the coupler. The tongue jack is mounted to the A-frame (front or tongue) part of the trailer. By rotating the jack handle clockwise, the jack will extend and raise the tongue of the trailer.

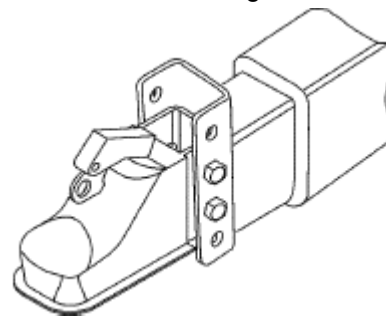

Figure 2-C. Ball Hitch Coupler

Before each tow, coat the ball with a thin layer of automotive bearing grease to reduce wear and ensure

proper operation. Check the locking device that secures the coupler to the ball for proper operation.

If you see or feel evidence of wear, such as flat spots, deformations, pitting or corrosion, on the ball or coupler, immediately have your dealer inspect them to determine the proper action to prevent possible failure of the ball and coupler system. All bent or broken coupler parts must be replaced before towing the trailer.

The coupler handle lever must be able to rotate freely and automatically snap into the latched position. Oil the pivot points, sliding surfaces, and spring ends with SAE 30W motor oil. Keep the ball socket and latch mechanism clean. Dirt or contamination can prevent proper operation of the latching mechanism.

The load rating of the coupler and the necessary ball size are listed on the trailer tongue. You must provide a hitch and ball for your tow vehicle where the load rating of the hitch and ball is equal to or greater than that of your trailer.

Also, the ball size must be the same as the coupler size. If the hitch ball is too small, too large, is underrated, is loose or is worn, the trailer can come loose from the tow vehicle and may cause death or serious injury.

The tow vehicle, hitch and ball must have a rated towing capacity equal to or greater than the trailer Gross Vehicle Weight Rating (GVWR). It is essential that the hitch ball be of the same size as the coupler.

The ball size and load rating (capacity) are marked on the ball. Hitch capacity is marked on the hitch.



WARNING

Coupler-to-hitch mismatch can result in uncoupling, leading to death or serious injury.

Be sure the **LOAD RATING** of the hitch ball is equal or greater than the load rating of the coupler.

Be sure the **SIZE** of the hitch ball matches the size of the ball coupler.



WARNING

A worn, cracked or corroded hitch ball can fail while towing and may result in death or serious injury.

Before coupling trailer, inspect the hitch ball for wear, corrosion and cracks.

Replace worn or damaged hitch ball.



WARNING

A loose hitchball nut can result in uncoupling, leading to death or serious injury.

Be sure the hitch ball is tight to the hitch before coupling the trailer.

- Rock the ball to make sure it is tightened to the hitch, and visually check that the hitch ball nut is solid against the lock washer and hitch frame.
- Wipe the inside and outside of the pintle coupler. Clean and inspect it visually for cracks and deformations. Feel the inside of the coupler for worn spots and pits. Replace the coupler if any of these conditions are found.
- Be sure the coupler is secured tightly to the tongue of the trailer. All coupler fasteners must be visibly solid against the trailer frame.
- The bottom surface of the coupler must be above the top of the hitch ball. Use the tongue jackstand to support the trailer tongue. Wood or concrete blocks may also be used.

Coupling the Trailer to the Tow Vehicle (Ball Coupler)

- Lubricate the hitch ball and the inside of the coupler with a thin layer of automotive bearing grease.
- Slowly back up the tow vehicle so that the hitch ball is near or aligned under the coupler.
- Using the jackstand at the front of trailer (tongue), turn the jackstand crank handle to raise the trailer. If the ball

coupler does not line up with the hitch ball, adjust the position of the tow vehicle.

- Open the coupler locking mechanism. Ball couplers have a locking mechanism with an internal moving piece and an outside handle. In the open position, the coupler is able to drop fully onto the hitch ball.
- Lower the trailer (Figure 2-D) until the coupler fully engages the hitch ball.

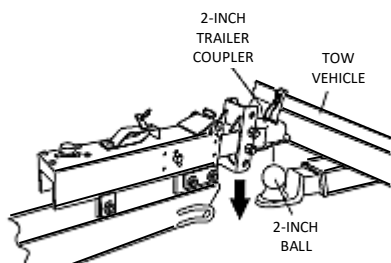

Figure 2-D. Ball Hitch Coupling Mechanism

- Engage the coupler locking mechanism. In the engaged position, the locking mechanism securely holds the coupler to the hitch ball.
- Insert a pin or lock through the hole in the locking mechanism.
- Be sure the coupler is all the way on the hitch ball and the locking mechanism is engaged. A properly engaged locking mechanism will allow the coupler to raise the rear of the tow vehicle. Using the trailer jackstand, verify that you can raise the rear of the tow vehicle by 1 inch after the coupler is locked to the hitch.
- Lower the trailer so that its entire tongue weight is held by the hitch.
- Raise the jackstand to a height where it will not interfere with the road.

NOTICE

Overloading can damage the tongue jack. **Do Not** use the tongue jack to raise the tow vehicle more than one inch.

If the coupler cannot be secured to the hitch ball, do not tow the trailer. Call your dealer for assistance. Lower the trailer so that its entire tongue weight is held by the hitch and continue retracting the jack to its fully retracted position.

Attaching Safety Chain

Inspect the safety chains and hooks for wear or damage. Replace worn or damaged safety chains and hooks before towing.

Attach the safety chains so that they:

- Cross underneath the coupler. See Figure 2-E.

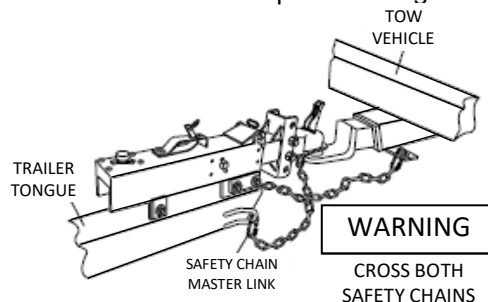

Figure 2-E. Attaching Safety Chain (Ball Hitch)

- Loop around a frame member of the tow vehicle or holes provided in the hitch system (DO NOT attach them to an interchangeable part of the hitch assembly).
- Have enough slack to permit tight turns, but not be close to the road surface, so if the trailer uncouples, the safety chains can hold the tongue up above the road.



WARNING

Improper rigging of the safety chains can result in loss of control of the trailer and tow vehicle, leading to death or serious injury, if the trailer uncouples from the tow vehicle.

- Fasten chains to frame of tow vehicle. DO NOT fasten chains to any part of the hitch unless the hitch has holes or loops specifically for that purpose.

- Cross chains underneath hitch and coupler with enough slack to permit turning and to hold tongue up, if the trailer comes loose.

Breakaway Brake System

If the coupler or hitch fails, a properly connected and working breakaway brake system (Figure 2-F) will apply the hydraulic brakes on the trailer. The safety chains will keep the tow vehicle attached and as the brakes are applied at the trailer's axles, the trailer/tow vehicle combination will come to a controlled stop.

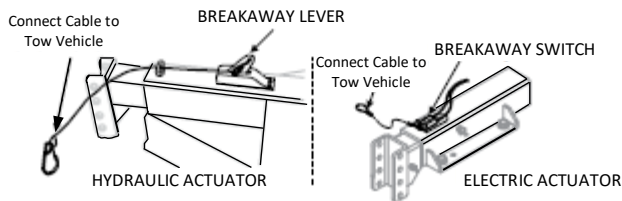

Figure 2-F. Breakaway Brake

Breakaway Cable Surge Brake System

The breakaway brake system includes a brake cable connected to the tow vehicle on one end and to the emergency brake lever located on the hydraulic actuator on the other end.

WARNING

- An ineffective breakaway brake system can result in a runaway trailer, leading to death or serious injury, if the coupler or ball hitch fails.
- Connect the breakaway cable to the tow vehicle and NOT to the hitch, ball or support.
- Before towing the trailer, test the function of the breakaway brake system. If the breakaway brake system is not working, **Do Not** tow the trailer. Have it serviced or repaired.

NOTICE

Do Not tow the trailer with the breakaway brake system ON because the brakes will overheat which can result in permanent brake failure.

NOTICE

Replace the breakaway brake battery (if equipped) at intervals specified by manufacturer.

Connecting Trailer Lights

Connect the trailer lights to the tow vehicle's electrical system using the electric connectors at the front of the trailer (tongue). Refer to the wiring diagram shown in the trailer wiring diagram section of this manual. Before towing the trailer check for the following:

- Running lights (turn on tow vehicle headlights).
- Brake Lights (step on tow vehicle brake pedal).
- Backup Lights (place tow vehicle gear shift in reverse).
- Turn Signals (activate tow vehicle directional signal lever).



WARNING

Improper electrical connection between the tow vehicle and the trailer will result in inoperable lights and electric brakes, and can lead to collision.

Before each tow:

- Check that the taillights, brake lights and turn signals work.
- Check that the electric brakes work by operating the brake controller inside the tow vehicle.

Uncoupling the Ball Hitch

Follow these steps to uncouple ball hitch from tow vehicle:

- Block trailer tires to prevent the trailer from rolling, before jacking the trailer up.
- Disconnect the electrical connector.
- Disconnect the breakaway brake switch cable. Promptly replace the pullpin in the switchbox.
- Before extending jackstand, make certain the ground surface below the jackstand foot will support the tongue load.

- Rotate the jackstand handle (or crank) clockwise. This will slowly extend the jack and transfer the weight of the trailer tongue to the jack.

Pintle Hitch Coupler

A pintle eye coupler (Figure 2-G) connects to a pintle-hook hitch that is located on or under the rear bumper of the tow vehicle. This system of coupling a trailer to a tow vehicle is sometimes referred to as a “lunette eye, tow ring or G.I. hitch.”

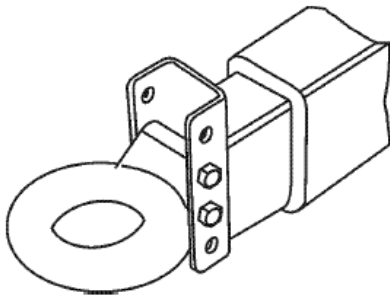

Figure 2-G. Pintle Hitch Coupler

A pintle hitch trailer may be fitted with a tongue jackstand that can raise and lower the coupler. The tongue jack is mounted to the A-frame (front or tongue) part of the trailer. By rotating the jack handle clockwise, the jack will extend and raise the tongue of the trailer.

The load rating of the coupler and the necessary pintle hitch size are listed on the trailer tongue. You must provide a pintle hitch and pintle coupler for your tow vehicle, where the load rating of the pintle hitch and pintle coupler is equal to or greater than that of your trailer.

Also, the pintle hitch size must be the same as the pintle coupler size. If the hitch is too small, too large, underrated, loose or worn, the trailer can come loose from the tow vehicle, and may cause death or serious injury.

Pintle Coupler and Pintle Hook

Before each tow, check the locking device that secures the coupler to the pintle hook assembly.

The pintle hook lever must be able to operate freely and automatically snap into place into the latched position.

Lightly oil the pivot points and sliding surfaces with SAE30W motor oil to prevent rust and help ensure proper operation of the latching mechanism.

If you see or feel evidence of wear, such as flat spots, deformations, pitting or corrosion, on the pintle hook or coupler, immediately have your dealer inspect them to determine the proper action to prevent possible failure of the ball and coupler system. All bent or broken coupler parts must be replaced before towing the trailer.

The tow vehicle, pintle hitch and pintle coupler must have a rated towing capacity equal to or greater than the trailer **Gross Vehicle Weight Rating (GVWR)**.

It is essential that the pintle hitch be of the same size as the pintle coupler.

The coupler size and load rating (capacity) are marked on the coupler. Hitch capacity is marked on the hitch.

 WARNING
<p>Coupler-to-hitch mismatch can result in uncoupling, leading to death or serious injury.</p> <p>Be sure the LOAD RATING of the pintle hitch hook is equal or greater than the load rating of the pintle eye coupler.</p> <p>Be sure the SIZE of the pintle hitch hook matches the size of the pintle eye coupler.</p>

 WARNING
<p>A worn, cracked or corroded pintle hitch hook can fail while towing, and may result in death or serious injury.</p> <p>Before coupling trailer, inspect the pintle hitch hook for wear, corrosion and cracks.</p> <p>Replace worn or damaged pintle hitch hook.</p>

- Rock the pintle eye coupler to make sure it is secured tightly to the hitch.

- Wipe the inside and outside of the pintle coupler. Clean and inspect it for cracks and deformations. Feel the inside of the coupler for worn spots and pits.

- Be sure the coupler is secured tightly to the tongue of the trailer. All coupler fasteners must be visibly solid against the trailer frame.

- Raise the bottom surface of the coupler to be above the top of the pintle hitch hook. Use the tongue jackstand to support the trailer tongue. Wood or concrete blocks may also be used.

⚠ WARNING

A defective pintle hitch not properly fastened can result in uncoupling, leading to death or serious injury.

Be sure the pintle hook is securely tighten to the tow vehicle before coupling the trailer.

Coupling trailer to tow vehicle (pintle Coupler)

- Slowly back up the tow vehicle so that the pintle hitch hook is near or aligned under the pintle eye ring coupler.

- Using the jackstand at the front of trailer (tongue), turn the jackstand crank handle to raise the trailer. If the pintle eye coupler does not line up with the pintle hitch hook, adjust the position of the tow vehicle.

- OPEN the pintle hook locking mechanism (Figure 2-H). Place the hook inside the eye coupler. CLOSE the pintle hook mechanism.

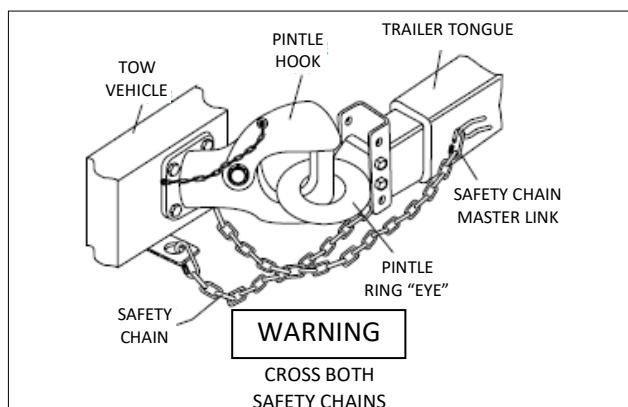

Figure 2-H. Attaching safety Chain (Pintle Hitch)

- Insert a pin or lock through the hole in the locking mechanism.

- Be sure the pintle hook is inserted completely through the eye ring and the locking mechanism is engaged. A properly engaged locking mechanism will allow the coupler to raise the rear of the tow vehicle. Using the trailer jack, test to see that you can raise the rear of the tow vehicle by 1-inch after the coupler is locked to the hitch.

- Lower the trailer so that its entire tongue weight is held by the hitch.

- Raise the jackstand to a height where it will not interfere with the road.

Tire safety

Unsafe Tires, Lug Nuts or Wheels

Trailer tires and wheels are more likely to fail than car tires and wheels because they carry a heavier load. Therefore, it is essential to inspect the trailer tires before each tow.

If a tire has a bald spot, bulge, cuts, is showing any cords, or is cracked, replace the tire before towing. If a tire has uneven tread wear, take the trailer to a dealer service center for diagnosis.

Uneven tread wear can be caused by tire imbalance, axle misalignment or incorrect inflation.

Tires with too little tread will not provide adequate tracking on wet roadways and can result in loss of control, leading to death or serious injury.

Improper tire pressure causes an unstable trailer and can result in a tire blowout and loss of control. Therefore, before each tow you must also check the tire pressure. Tire pressure must be checked when tires are cold.

Allow 3 hours cool-down after driving as much as 1 mile at 40 mph before checking tire pressure. Trailer tires will be inflated to higher pressures than passenger vehicle tires.

Since trailer wheels and lug nuts (or bolts) are subjected to greater side loads than automobile wheels, they are more prone to loosen. Before each tow, check to make sure they are tight.

The proper tightness (torque) for lug nuts is listed in the lug nut tightening section of this manual. Use a torque wrench to tighten the lug nuts. If you do not have a torque wrench, use a lug wrench (from your tow vehicle) and tighten the nuts as much as you can. Then have a Service garage or trailer dealer tighten the lug nuts to the proper torque.

WARNING

Metal creep between the wheel rim and lug nuts will cause rim to loosen and could result in a wheel coming off, leading to death or serious injury.

Tighten lug nuts before each tow.

Lug nuts are also prone to loosen after first being assembled. When driving a new trailer (or after wheels have been remounted), check to make sure they are tight after the first 10, 25 and 50 miles of driving and before each tow thereafter.

Failure to perform this check can result in a wheel parting from the trailer and a crash, leading to death or serious injury.

WARNING

Lug nuts are prone to loosen after initial installation, which can lead to death or serious injury.

Check lug nuts for tightness on a new trailer or when wheel(s) have been remounted after the first 10, 25 and 50 miles of driving.

WARNING

Improper lug nut torque can cause a wheel parting from the trailer, leading to death or serious injury.

Be sure lug nuts are tight before each tow.

WARNING

Improper tire pressure can result in a blowout and loss of control, which can lead to death or serious injury.

Be sure tires are inflated to pressure indicated on side wall before towing trailer.

Determining Load Limit of Trailer

Determining the load limits of a trailer includes more than understanding the load limits of the tires alone. On all trailers there is a Federal certification/VIN label that is located on the forward half of the left (road) side of the unit. This certification/VIN label will indicate the trailer’s Gross Vehicle Weight Rating (GVWR). This is the most weight the fully loaded trailer can weigh. It will also provide the Gross Axle Weight Rating (GAWR). This is the most the axle can weigh.

There is a vehicle placard (Figure 2-J) located in the same location as the certification label described above. This placard provides tire and loading information. In addition, this placard will show a statement regarding maximum cargo capacity.

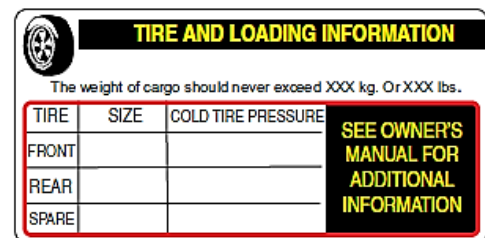

Figure 2-J. Trailer Tire Placard

If additional work items (hoses, tools, clamps etc.) are going to be added to the trailer, be sure they are distributed evenly to prevent overloading front to back and side to side. Heavy items should be placed low and as close to the axle positions as reasonable. Too many items on one side may overload a tire.

Excessive loads and/or underinflation cause tire overloading and, as a result, abnormal tire flexing occurs. This situation can generate an excessive amount of heat within the tire. Excessive heat may lead to tire failure. It is the air pressure that enables a tire to

support the load, so proper inflation is critical. The proper air pressure may be found on the certification/VIN label and/or on the Tire and Loading Information placard. This value should **never** exceed the maximum cold inflation pressure stamped on the tire.

Perform the following steps to determine the load limit of your trailer.

Step 1.

Locate the statement, "The weight of cargo should never exceed XXX kg or XXX lbs.," on your vehicle's Tire and Loading Information placard (Figure 2-J). This value equals the available amount of equipment load capacity.

Step 2.

Determine the weight of the equipment being loaded on the tow vehicle. That weight may not safely exceed the available equipment load capacity. The trailer's Tire Information Placard is attached adjacent to or near the trailer's VIN (Certification) label at the left front of the trailer (See Figure 2-A).

Determining Load Limit of Tow Vehicle

Step 1.

Locate the statement, "The combined weight of occupants and cargo should never exceed XXX lbs.," on your vehicle's placard.

Step 2.

Determine the combined weight of the driver and passengers who will be riding in your vehicle.

Step 3.

Subtract the combined weight of the driver and passengers from XXX kilograms or XXX pounds.

Step 4.

The resulting figure equals the available amount of cargo and luggage capacity. For example, if the "XXX" amount equals 1400 lbs and there will be five 150 lb passengers in your vehicle, the amount of available cargo and luggage capacity is 650 lbs. (1400 - (5 x 150) = 650 lbs.).

Step 5.

Determine the combined weight of luggage and cargo being loaded on the vehicle. That weight may not safely exceed the available cargo and luggage capacity calculated in Step 4.

If your vehicle will be towing a trailer, load from your trailer will be transferred to your vehicle. Consult the tow vehicle's manual to determine how this weight transfer reduces the available cargo and luggage capacity of your vehicle.

Studies of tire safety show that maintaining proper tire pressure, observing tire and vehicle load limits (not carrying more weight in your vehicle than your tires or vehicle can safely handle), avoiding road hazards and inspecting tires for cuts, slashes and other irregularities are the most important things you can do to avoid tire failure, such as tread separation or blowout and flat tires. These actions, along with other care and maintenance activities, can also:

- Improve vehicle handling.
- Help protect you and others from avoidable breakdowns and accidents.
- Improve fuel economy.
- Increase the tire life.

Use the information contained in this section to make tire safety a regular part of your vehicle maintenance routine. Recognize that the time you spend is minimal compared with the inconvenience and safety consequences of a flat tire or other tire failure.

Tire Fundamentals

Federal law requires tire manufacturers to place standardized information on the sidewall of all tires (Figure 2-K). This information identifies and describes the fundamental characteristics of the tire and also provides a tire identification number for safety standard certification and in case of a recall.

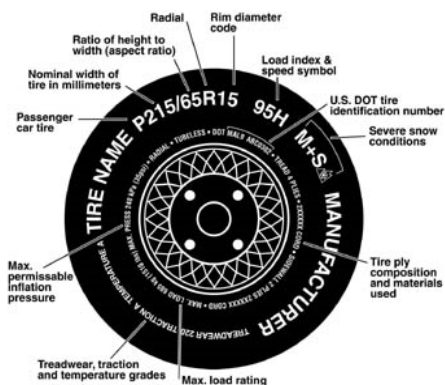

Figure 2-K. Standard Tire Sidewall Information

P: The “P” indicates the tire is for passenger vehicles.

Next number: This three-digit number gives the width in millimeters of the tire from sidewall edge to sidewall edge. In general, the larger the number, the wider the tire.

Next number: This two-digit number, known as the aspect ratio, gives the tire’s ratio of height to width. Numbers of 70 or lower indicate a short sidewall for improved steering response and better overall handling on dry pavement.

P: The “R” stands for radial. Radial ply construction of tires has been the industry standard for the past 20 years.

Next number: This two-digit number is the wheel or rim diameter in inches. If you change your wheel size, you will have to purchase new tires to match the new wheel diameter.

Next number: This two- or three-digit number is the tire’s load index. It is a measurement of how much weight each tire can support. You may find this information in your owner’s manual. If not, contact a local tire dealer. *Note:* You may not find this information on all tires because it is not required by law.

M+S: The “M+S” or “M/S” indicates that the tire has some mud and snow capability. Most radial tires have these markings; hence, they have some mud and snow capability.

Speed Rating: The speed rating denotes the speed at which a tire is designed to be driven for extended periods of time. The ratings range from 99 miles per hour (mph) to 186 mph. These ratings are listed in Table A. *Note:* You may not find this information on all tires because it is not required by law.

Table 2A. Speed Rating	
Letter Rating	Speed Rating
Q	99 mph
R	106 mph
S	112 mph
T	118 mph
U	124 mph
H	130 mph
V	149 mph
W	168* mph
Y	186* mph

U.S. DOT Tire Identification Number: This begins with the letters “DOT” and indicates that the tire meets all federal standards. The next two numbers or letters are the plant code where it was manufactured, and the last four numbers represent the week and year the tire was built. For example, the numbers 3197 means the 31st week of 1997. The other numbers are marketing codes used at the manufacturer’s discretion. This information is used to contact consumers if a tire defect requires a recall.

Tire Ply Composition and Materials Used: The number of plies indicates the number of layers of rubber-coated fabric in the tire. In general, the greater the number of plies, the more weight a tire can support. Tire manufacturers also must indicate the materials in the tire, which include steel, nylon, polyester, and others.

Maximum Load Rating: This number indicates the maximum load in kilograms and pounds that can be carried by the tire.

Maximum Permissible Inflation Pressure: This number is the greatest amount of air pressure that should be put in the tire under normal driving conditions.

Uniform Tire Quality Grading Standards (UTQGS)

Treadwear Number: This number indicates the tire's wear rate. The higher the treadwear number is, the longer it should take for the tread to wear down. For example, a tire graded 400 should last twice as long as a tire graded 200.

Traction Letter: This letter indicates a tire's ability to stop on wet pavement. A higher graded tire should allow you to stop your car on wet roads in a shorter distance than a tire with a lower grade. Traction is graded from highest to lowest as "AA", "A", "B", and "C".

Temperature Letter: This letter indicates a tire's resistance to heat. The temperature grade is for a tire that is inflated properly and not overloaded. Excessive speed, underinflation or excessive loading, either separately or in combination, can cause heat build-up and possible tire failure. From highest to lowest, a tire's resistance to heat is graded as "A", "B", or "C".

Refer to Figure 2-L for additional tire information for light trucks.

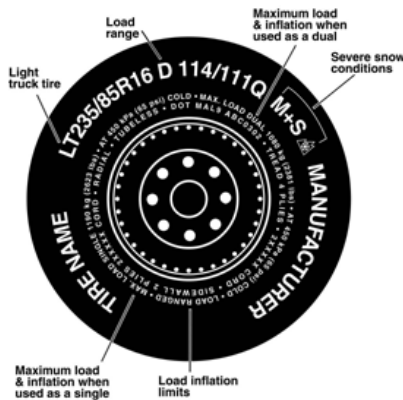

Figure 2-L

Tires for light trucks have other markings besides those found on the sidewalls of passenger tires.

LT: The "LT" indicates the tire is for light trucks or trailers.

ST: An "ST" is an indication the tire is for trailer use only.

Max. Load Dual: kg (lbs) at kPa (psi) Cold: This information indicates the maximum load and tire

pressure when the tire is used as a dual, that is, when four tires are put on each rear axle (a total of six or more tires on the vehicle).

Max. Load Single: kg (lbs) at kPa (psi) Cold: This information indicates the maximum load and tire pressure when the tire is used as a single.

Load Range: This information identifies the tire's load carrying capabilities and its inflation limits.

Tire Safety Tips

- Slow down if you have to go over a pothole or other object in the road.
- **Do Not** run over curbs or other foreign objects in the roadway, and try not to strike the curb when parking.
- Check tire inflation pressure weekly during use to insure the maximum tire life and tread wear.
- **Do Not** bleed air from tires when they are hot.
- Inspect tires for uneven wear patterns on the tread, cracks, foreign objects, or other signs of wear or trauma.
- Remove bits of glass and foreign objects wedged in the tread.
- Make sure your tire valves have valve caps.
- **Always** check tire pressure on tow vehicle and trailer before towing. Check tire pressure at least once a month.
- **Do Not** overload tow vehicle. Check the tire information and loading placard for safe allowable tire loading conditions.







Tire Repair

The proper repair of a punctured tire requires a plug for the hole and a patch for the area inside the tire that surrounds the puncture hole. Punctures through the tread can be repaired if they are not too large, but punctures to the sidewall should not be repaired. Tires must be removed from the rim to be properly inspected before being plugged and patched.

Replacing Worn or Damaged Tires

Replace the tire before towing the trailer if the tire treads have less than 1/16 inch depth or the telltale bands are visible. Check inflation pressure weekly during use to insure the maximum tire life and tread wear. A bubble, cut or bulge in a side wall can result in a tire blowout. Inspect both side walls of each tire for any bubble, cut or bulge; and replace a damaged tire before towing the trailer.

Table 2B below will help pinpoint the causes and solutions of tire wear problems.

Table 2B. Tire Wear Troubleshooting			
Wear Pattern		Cause	Solution
	Center Wear	Over inflation	Adjust pressure to particular load per tire manufacturer
	Edge Wear	Under inflation	Adjust pressure to particular load per tire manufacturer
	Side Wear	Loss of camber or overloading	Make sure load does not exceed axle rating. Align wheels.
	Toe Wear	Incorrect toe-in	Align wheels
	Cupping	Out-of-balance	Check bearing adjustment and balance tires
	Flat Spots	Wheel lockup and tire skidding	Avoid sudden stops when possible and adjust brakes

WARNING

Always wear safety glasses when removing or installing force fitted parts. **Do not** attempt to repair or modify a wheel. **Do Not** install an inner-tube to correct a leak through the rim. If the rim is cracked, the air pressure in the inner tube may cause pieces of the rim to explode (break off) with great force and cause serious eye or bodily injury.

Wheel Rims

If the trailer has been struck, or impacted, on or near the wheels, or if the trailer has struck a curb, inspect the rims for damage (i.e. being out of round); and replace any damaged wheel. Inspect the wheels for damage every year, even if no obvious impact has occurred.

Wheels, Bearings and lug nuts

A loose, worn or damaged wheel bearing is the most common cause of brakes that grab.

To check wheel bearings, jack trailer and check wheels for side-to-side looseness. If the wheels are loose, or spin with a wobble, the bearings must be serviced or replaced. Check inflation pressure weekly during use to insure the maximum tire life and tread wear. Most trailer axles are built with sealed bearings that are not serviceable. Sealed bearings must be replaced as complete units.

NOTICE

Never use a pneumatic air gun to tighten wheel lug nuts.

Over-tightening lug nuts will result in breaking the studs or permanently deforming the mounting stud holes in the wheels.

WARNING

Lug nuts are prone to loosen after initial installation, which can lead to death or serious injury. Check all wheel lug nuts periodically.

Lug Nut Torque Requirements

It is extremely important to apply and maintain proper wheel mounting torque on the trailer. Be sure to use only the fasteners matched to the cone angle of the wheel. Proper procedure for attachment of the wheels is as follows:

1. Start all wheel lug nuts by hand.
2. Torque all lug nuts in sequence. See Figure 2-M. **Do Not** torque the wheel lug nuts all the way down. Tighten each lug nut in 3 separate passes as defined by Table 3A.
3. Check to see if the lug nuts are tight after the first 10, 25 and 50 miles of driving and before each tow thereafter.

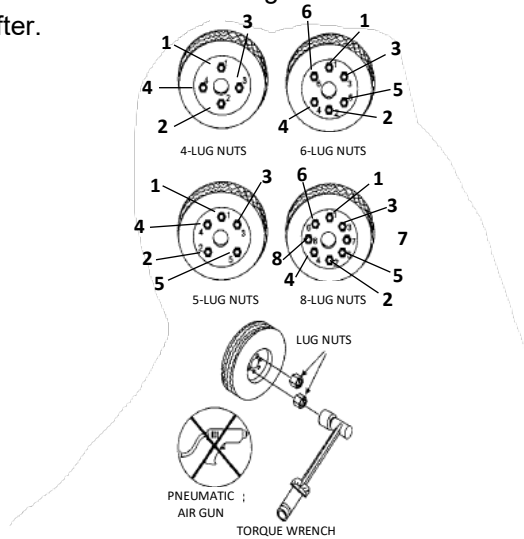

Figure 2-M. Wheel Lug Nuts Tightening Sequence

Table 2C. Tire Torque Requirements

Wheel Size	First Pass FT-LBS	Second Pass FT-LBS	Third Pass FT-LBS
12"	20-25	35-40	50-65
13"	20-25	35-40	50-65
14"	20-25	50-60	90-120
15"	20-25	50-60	90-120
16"	20-25	50-60	90-120

Lights and Signals

Before each tow, check the trailer taillights, stoplights, turn signals and any clearance lights for proper operation.

Replace any broken or burned-out lamps as necessary. Check the wire harness for cuts, fraying or other damage. If it needs replacing, contact your dealer.

WARNING

Improper operating taillights, stoplights and turn signals can cause collisions.

Check all lights before each tow.

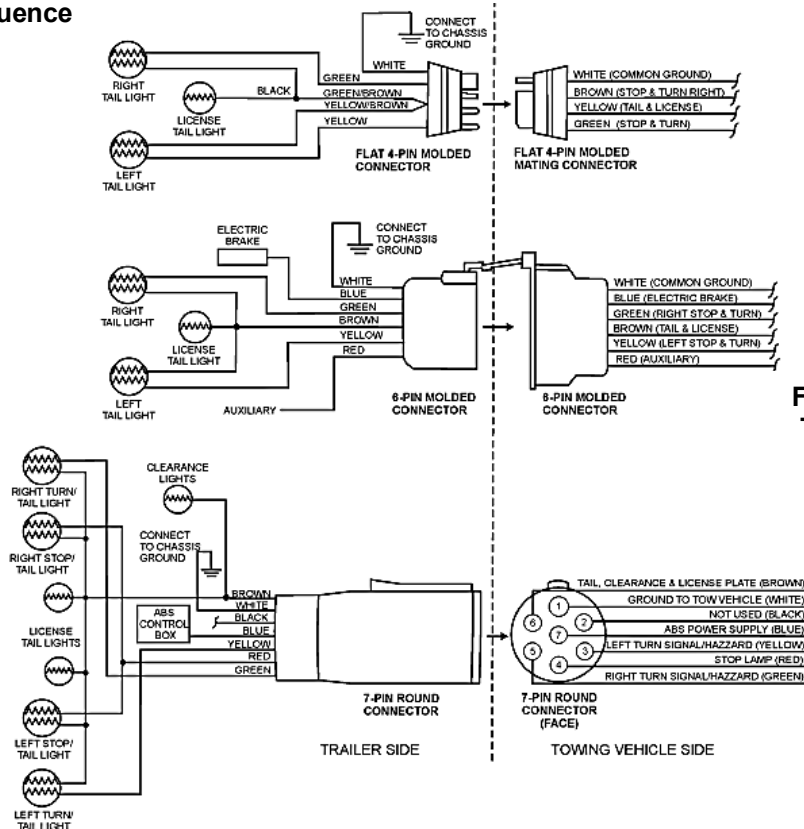

Figure 2-N. Trailer to Tow Vehicle Wiring Diagram

Pre-Operation Checklist

Injuries and fatalities can come from detectable potential equipment failure when an operator has not properly inspected and assessed equipment before and after use. These inspections are often neglected and are poorly documented.

Safety is the primary and obvious reason that daily inspections should be conducted and so is compliance because thousands of dollars could be spent based on

failure to determine the equipment safety prior to operation.

In addition to the safety and compliance related to equipment safety, there's also potential cost-savings related to proactive discovery of issues and predictive maintenance of your equipment. Finding issues early limits downtime and prevents a more expensive repair. Following a pre-operation inspection routine is not that difficult, but it does take a high level of discipline from the operator.

DAILY PRE-OPERATION CHECKLIST

Daily Pre-Operation Checklist		✓	✓	✓	✓	✓	✓
1	Hardware and damage check						
2	Engine oil and fluid levels						
3	Braking control operation						

Inspection and Setup

Engine Oil

When checking the engine oil, be sure to check if the oil is clean. If the oil is not clean, drain the oil by removing the oil drain plug, and refill with the specified amount of oil. Oil should be warm before draining.

The primary Cummins Inc. recommendation is for the use of 15W-40 multigrade lubricating oil for normal operation at ambient temperatures above -15°C [5°F].

Use of "synthetic engine oils" (those made with API group 3 or group 4 base stocks) is permitted, subject to the same performance and viscosity limitations of petroleum (mineral) based engine oils.

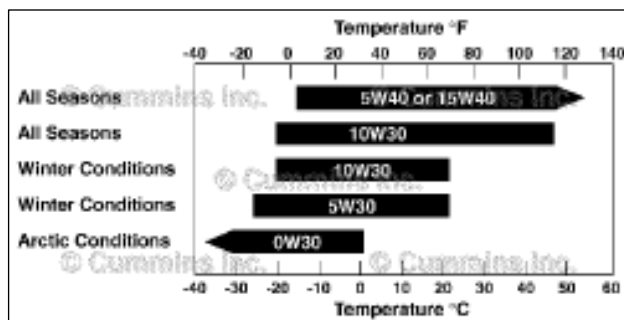

Table 3A. Engine Oil Grades

Checking Engine Oil

1. Make sure pump is placed on secure level ground.
2. Remove the engine oil dipstick from its holder.
3. Verify that the oil level (Figure 3-A) is maintained between the two notches on the dipstick.

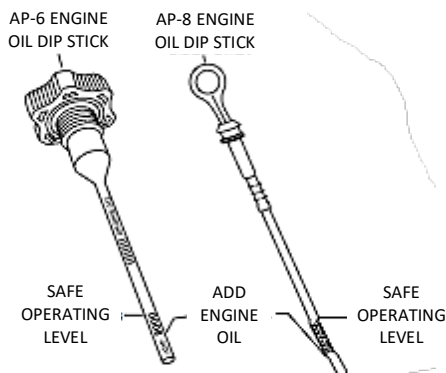

Figure 3-A. Oil Dipstick

4. If engine oil is low, fill engine crankcase with lubricating oil through filler hole (Figure 3-B), but **Do Not** overfill.

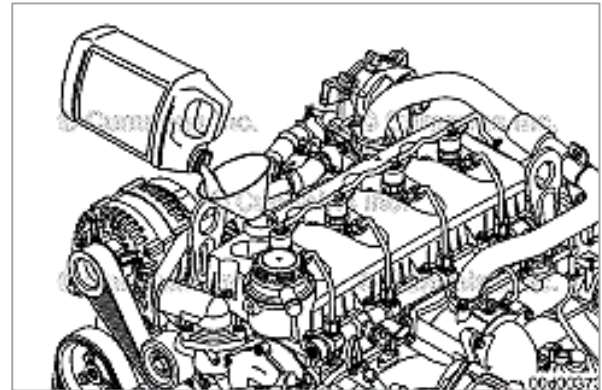



Figure 3-B. Engine Oil Filler Hole

Fuel Check

! DANGER

Never fill the fuel tank while the engine is running or in the dark. Fuel spillage on a hot engine can cause a fire or explosion. If fuel spillage occurs, wipe up the spilled fuel completely to prevent fire hazards.



1. The fuel tank used with this pump has a built-in fuel gauge (Figure 3-C) within the tank. Read the fuel gauge to determine if the fuel level is low.

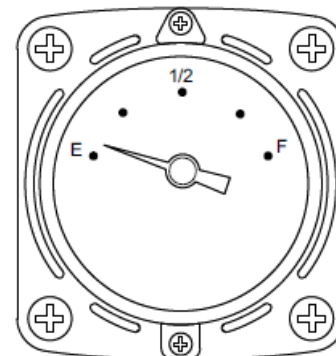
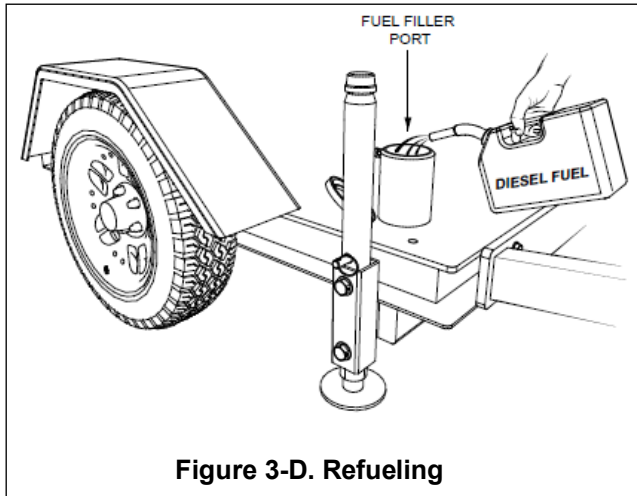

Figure 3-C. Fuel Gauge

2. Handle fuel in a safety container. If the container does not have a spot, use a funnel.
3. If the fuel level is low, fill (Figure 3-D) with recommended type diesel fuel. **DO NOT** fill fuel tank beyond capacity



4. Pay attention to the fuel tank capacity when replenishing fuel. Refer to the fuel tank capacity listed in Table 4C, Trailer specifications.
5. Tighten the fuel tank cap securely after filling.

Battery Cable Connection

Always make sure the battery cables are properly connected to the battery terminals. The RED cable is connected to the positive terminal of the battery, and the BLACK cable is connected to the negative terminal.

Pump Placement

1. Read safety instructions at the beginning of the manual.
2. Place pump on secure level ground as near to the water as possible.
3. Deploy all four trailer jack stands to level the pump. If possible, place chock blocks underneath each wheel to prevent the pump from rolling.

Suction/Discharge Hose Connections

!
DANGER

PVC discharge hoses and thin-walled rubber hoses can easily fail at the end of the hose fittings. Leaks from the hoses can cause high-pressure liquid to be discharged, causing dangerous conditions. Make sure pressure rating of hoses exceeds the pump maximum pressure to prevent hose failure.



1. Check that the suction and discharge hoses (Figure 3-E) are securely attached to the pump via Bauer™ couplers (when used) and are not restricted.
2. Place each hose so that it lays as straight as it is possible on the ground. Remove any twists or sharp bends from hose which may block the flow of water.
3. If using a light weight discharge hose, it should be anchored to avoid movement with high flow or high pressure water. **Always** use a suction hose or pipe that matches the size of the pump inlet to insure optimum performance and reduce the risk of damage to the pump.

NOTICE

It is recommended that the discharge hose or pipe match the size of the pump outlet to reduce friction as much as possible. Using a discharge line that is larger than the pump outlet will reduce friction and improve water flow. Similarly, a smaller line will reduce water flow by increasing friction.

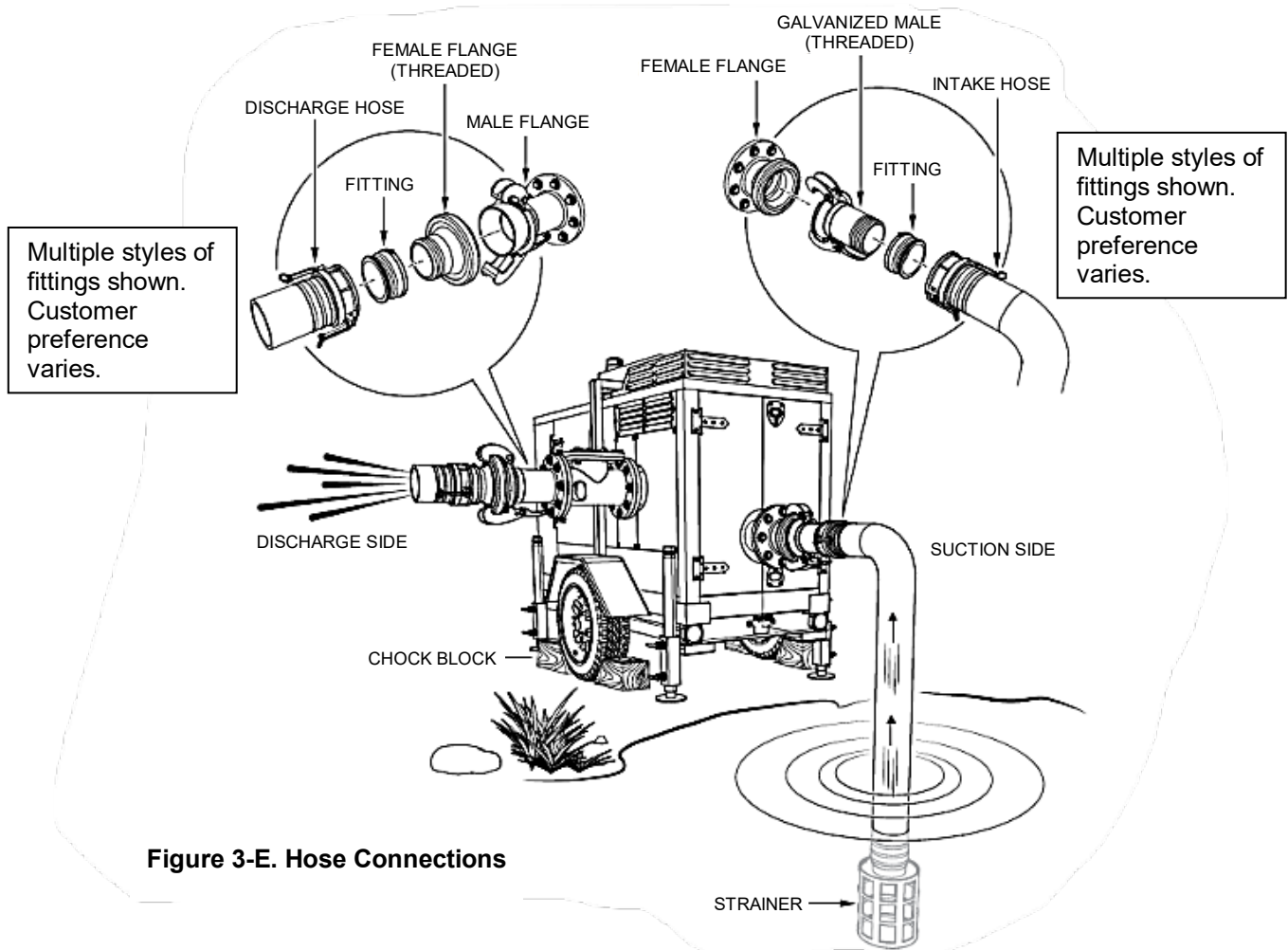

Figure 3-E. Hose Connections

4. Shorter suction lift and suction hose length will produce better performance.
5. Remember suction hoses must be rigid enough not to collapse when the pump is in operation.
6. Make sure the suction strainer is clean and securely attached to the water end of the suction hose. The strainer is designed to protect the pump by preventing large objects from being pulled into the pump. Failure to use a strainer could cause damage to the pump, impeller, pump shaft, pump bearings or wear plate.
7. If a strainer becomes clogged with debris, clean the strainer.

CAUTION

The strainer should be positioned so it will remain completely **under water**. Running the pump with the strainer above water for long periods can damage the pump.

DANGER

Do Not pump flammable liquids, corrosive chemicals or liquids containing toxic substances. These liquids can create potentially dangerous health and environmental hazards. Contact local authorities for assistance.

Introduction

The compressor priming pump is a multi-purpose compressor-assisted pump designed to operate on sumping and bypass applications. The unit consists of a centrifugal trash pump, diesel engine, drive coupling, frame, ENVIROPRIME® priming system and trailer (optional). The unit is completely automatic in its priming and operation and with minimal maintenance will give years of reliable service.

Installation

- Position pump as close as possible to the source of fluid to be pumped and place on a firm level surface. Remember to allow accessibility for proper operation, maintenance and refueling of the unit. To maximize pumping capacity, suction lifts should be kept to a minimum.
- Do not lift pump with suction and discharge piping or hoses attached.
- For sumping applications, an adequately sized strainer must be fitted to the end of the suction pipework. The strainer openings should be sized to prohibit objects larger than the solids capability of the pump from entering the pump.
- Be sure to provide sufficient submergence for the strainer.
- Remove all leaks from suction pipework to optimize pump performance.
- The suction and discharge piping diameter should be equal to or greater than the nominal size of the pump ports to minimize friction losses. The pipework should be kept as short as possible with a minimum number of fittings and elbows to minimize friction losses.
- The pipework must be supported immediately after the pump connections to prevent stress and possible misalignment of the equipment and must be restrained with adequate thrust blocks and/or binders to prevent separating under pressure.
- The suction pipework should be sloped upward to the pump from the source to prevent air pockets from forming which could inhibit priming.

Pre-Start Up

Perform the following before starting the pump:

1. Check all fluid levels.
2. Check battery and cables.
3. Check belts and hoses.
4. Ensure that all guards/covers are in place.
5. Close pump casing drain valve.
6. Open air line valve to the venturi.
7. Make sure the throttle control is set to the idle position.

Start Up & Operation

1. Insert key and turn to the run position.
2. Wait a couple of seconds and then turn the key to engage the starter. Once the engine starts, release the key and allow it to return to the run position. Do not attempt to crank the engine for more than 10 seconds at a time or you could damage the starter and drain the battery. Do not attempt to engage the starter while the engine is running.
3. Allow the engine to operate at idle speed for 1-2 minutes and then adjust throttle to desired setting. The pump should begin pumping water within a minute depending on the length of suction hose and height the pump is above water

NOTICE
Longer suction hoses require more time for the pump to begin pumping water.

4. If pump does **not** begin to pump water after a few minutes, check for loose connections or air leaks in the suction hose. Make sure there is water in the vacuum system and strainer is not clogged with debris. Reference the Pump Troubleshooting Guide in the Troubleshooting section of this manual.
5. Make certain suction hose does not have any air leakage. Tighten hose clamps and couplings as required.

6. Check for leaks between pump and engine. If water is leaking between the pump and bearing housing, the seal inside the pump may be worn or damaged. Continued operation of the pump is not recommended. Further usage of the pump under these conditions may cause severe water damage to bearing housing assembly.
7. Engine may be operated anywhere within the minimum and maximum speed range as set at the factory. Tampering with and readjusting these settings will void warranty.
8. Note: Paint on exhaust system may flake/ burn off overtime due to high heat in this area.
9. After starting, no other operator intervention is necessary. Pump may be left unattended except for daily maintenance.

Shutdown

1. After pumping is completed, use the throttle control to reduce the speed to idle and allow engine to run a few minutes to cool down.
2. Turn the key to the off position.
3. Open the pump casing drain valve to drain fluid.



CAUTION

If pumping in a positive head (pumping up hill), be sure to open discharge check valve drain and release pressure before uncoupling hose.

Pump Inspection after Use

1. It is recommended that the pump be inspected after each use for damage or wear.
2. Drain and flush pump volute and priming system. Usually from suction end.
3. Inspect impeller for wear or damage and measure impeller clearance if it appears worn. Inspect interval should be about every 1000 hours. This

inspection should be performed when the pump is scheduled for maintenance inspection.

4. Inspect discharge check valve for wear or damage. Replace if necessary.
5. Inspect fuel tank and check for water by removing 0.5- inch drain plugs. Do not overtighten when replacing.
6. Check oil reservoirs for contamination or water.
7. Do dry vacuum test to check seal and check valve seal. This check should be performed when the pump is scheduled for maintenance inspection.

Storage

- Drain pump when not in use or during cold weather.
- Apply a rust inhibitor to any unpainted surfaces.

For storage of the pump for over 30 days, the following is required:

- Drain the fuel tank completely.
- Run the engine until the fuel in the injection system is completely consumed.
- Completely drain used oil from the engine crankcase and fill with fresh clean oil, then follow the procedures described in the engine manual for engine storage.
- Remove the drain plug from the pump and drain out any water from left in the housing.
- Remove the pump cover and clean inside of pump housing. Coat inside of pump housing with a light film of oil to reduce corrosion. A spray can of oil works well for this application.
- Cover suction and discharge ports with duct tape to prevent any foreign matter from falling into pump.
- Cover pump and engine with plastic covering or equivalent and store in a clean, dry place.
- Refer to engine manufacturers' recommendations for any questions regarding the long term storage of engines.

QSF4X4 Pump Specifications

Table 4A – 4x4 Series Pump Specifications	
Model	QSF4x4
Pump Mounting	Site Trailer
Weight – kg [lb]	1474 [3250]
Suction x Discharge Size	4 inch x 4 inch
Max. Flow – lpm [gpm]	5110 [1350] @ 2400 RPM
Max. Head – m [ft]	41 [135]
Max. Head – kPa [PSI]	407 [59]
Suction Lift – m [ft]	8.5 [28]
Max. Solids – mm [in]	76.2 [3]
Max. Operating Temp. C° [F°]	93 [200]
Max. Operating Speed	2400 RPM
Max. <u>Volute</u> Pressure – kPa [PSI]	1206 [175]
Impeller Diameter – mm [in]	210 [8.25]
Volute Material	Class 30 Ductile Iron
Impeller Material	65-45-12 Ductile Iron
Shaft Material	SAE 1144 Stress-proof Steel
Mechanical Seal	Grease Lubricated
Mechanical Seal Faces	Tungsten Carbide/Silicon Carbide
Fuel Consumption – lph [gph]	11.4 [2.5] @ 1800 RPM
Operating Time	40 hours @ 1800 RPM (34 @ 2400)
Compressor Type	Integrally Mounted to Engine

4. SPECIFICATIONS

Pump Performance Curve

Model: QSF4X4
 Impeller Diameter: 8.25"

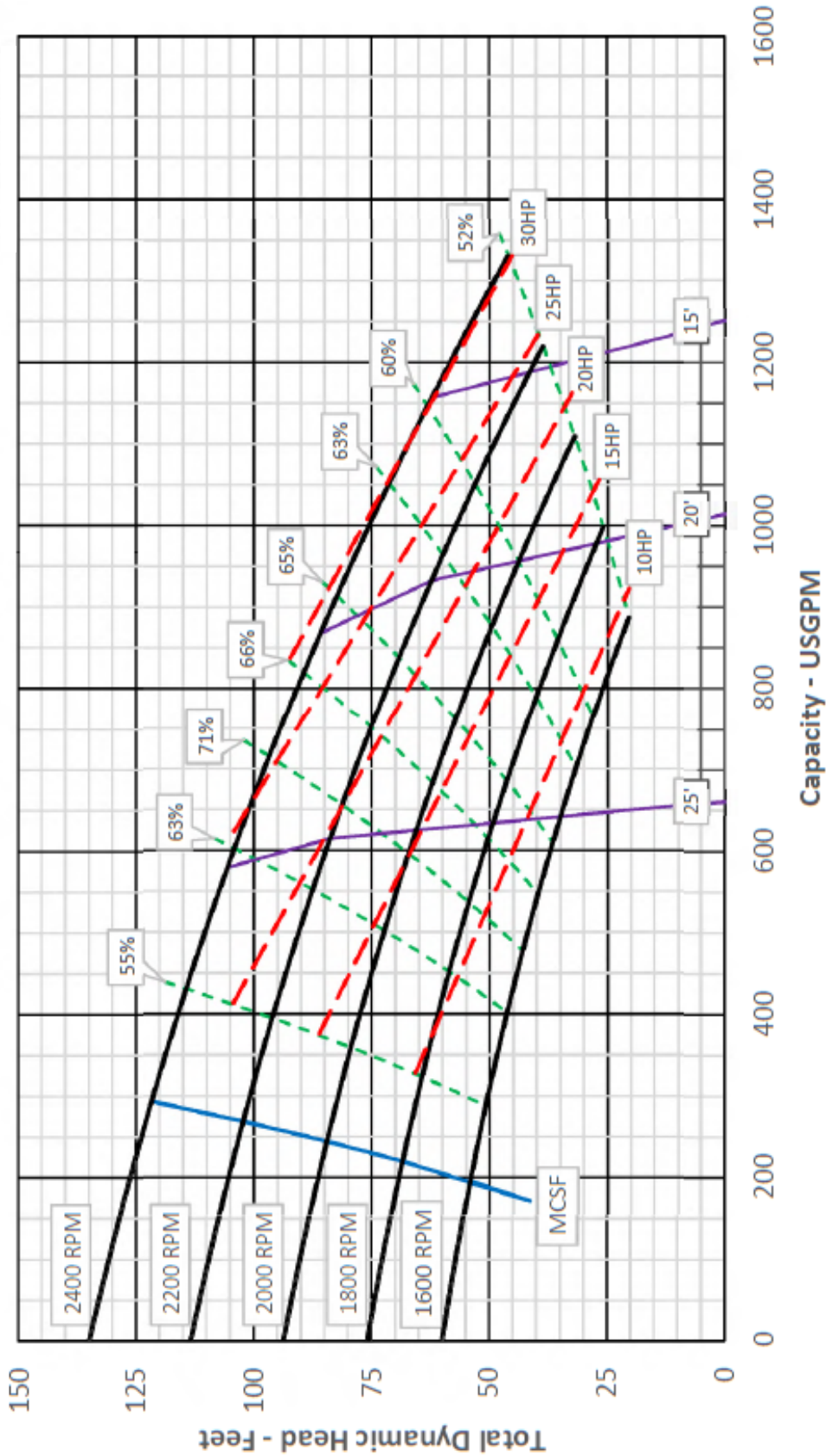

Test Conditions: Specific Gravity: 1.0 Temperature: 80°F Viscosity: 31.5 SSU Altitude: Sea Level
 Tests conducted according to Hydraulic Institute ANSI/HI 14.6 Standard.

Rev: 12/19



Engine Specifications

Table 4B. Engine Specifications	
Engine manufacturer	Cummins
Engine model	QSF2.8
Aspiration	Turbocharged charge air cooled and EGR
EPA Tier	Tier 4 Final
Number of cylinders	4
Max. continuous speed	2250 RPM
Bore/Stroke – mm [in]	94 x 100 [3.7 x 3.94]
Displacement – liters [cu. In]	2.8 [171]
Power – kW [hp] @ 2500 RPM	37 [49]
Compression ratio	16.9:1
Oil capacity – liters [quarts]	8.2 [8.66] Pan only - Aluminum
Oil type	15W-40 (Valvoline Premium Blue™ or equal) API1 CJ-4
Cooling system	Water Cooled
Coolant capacity – liters [quarts]	5 [5.3]
Fuel type	No. 2 Diesel; Ultra low Sulfur Diesel Fuel
Starting method	Electric Start
Battery	12V
Battery minimum CCA	850 Amperes
Weight – kg [lb]	244 [538]
Dimensions – in. (mm) (LxWxH)	724 x 633 x 818 [29 x 25 x 32]

Trailer Specifications

Table 4C. Trailer Specifications	
Axle, single – kg [lb]	2359 [5200]
Stabilizer jacks (Front/Rear)	3 (1-rear & 2-front)
Brakes	Electric
Coupler	Pintle Hitch
Tires (2)	15 inch
Lights	LED Trailer Lights
Safety chain, hook type – mm [in]	9.5 x 914 [3/8 x 36]
Fuel tank capacity – gallons (liters)	379 [100]
Dimensions, L x W – mm [in]	4166 x 1880 [164 x 74]

Auto Start/Stop Control Panel

This pump is provided with an advanced engine control panel. With high standards for technology, reputation and durability this panel can provide advanced pump control, combined with simple and intuitive operation. Available on all engine tier levels, including Final Tier 4.

Features

- Monitor suction and discharge pressures along with flow rates
- Pump monitoring and protection for inlet, outlet, flow and temperature
- Transducer control with float back up
- Automatic low battery monitoring and recharge run
- Inputs for high level alarm, auto start inhibit, low coolant, low oil level, auxiliary shutdown and others
- Low side outputs for engine run, unit in auto and fail to start
- OLED display for visibility in high sunlight areas and extreme temps
- Expansion modules compatible

Manual Operation

- Traditional key start operation
- Manual speed control with programmable min and max speeds
- Engine information display including oil pressure, coolant temp, speed, battery, fuel level and hours
- Diagnostic fault code reader
- Alarm and operation Logs
- Programmable maintenance alerts

Automatic Operation

- Visible and audible prestart warnings
- Single and dual float start/stop
- Automatic operation using pressure, level and temperature transducers
- Programmable weekly exercise timer

Automatic Throttle

- Speed control using warm up, prime, operating and cool down speeds
- Selectable throttle types including single speed, target and linear modes

Communications

- Ability to integrate with SCADA systems
- RS485 Modbus
- J1939 CANbus
- Relay contact expansion module compatible



Technical Specifications

Environmental		Electrical	
▪ Operating temperature -40° to + 80° C		▪ Operating voltage range 6 to 32 VDC	
▪ Storage temperature -40° to + 80° C		▪ Power consumption in low power mode 50mA	
▪ IP67			
Inputs		Outputs	
▪ 9 Digital, NO or NC		▪ 2-Ten amp form A	
▪ 3 resistive analog inputs		▪ 6-Five amp form A	
▪ 4 flex analog 4-20mA, 0-5 VDC			
▪ 1 speed capture			
Communication		Event Logs	
▪ RS485 MODbus		▪ Alarm, 64 Events	
▪ J1939 CANbus		▪ Operation, 64 Events	
Emission Compliance		Expandability	
▪ Compatible through Tier 4 Final		▪ Twist Throttle TT-100	
		▪ XCANI0 modules	



Pumping Application

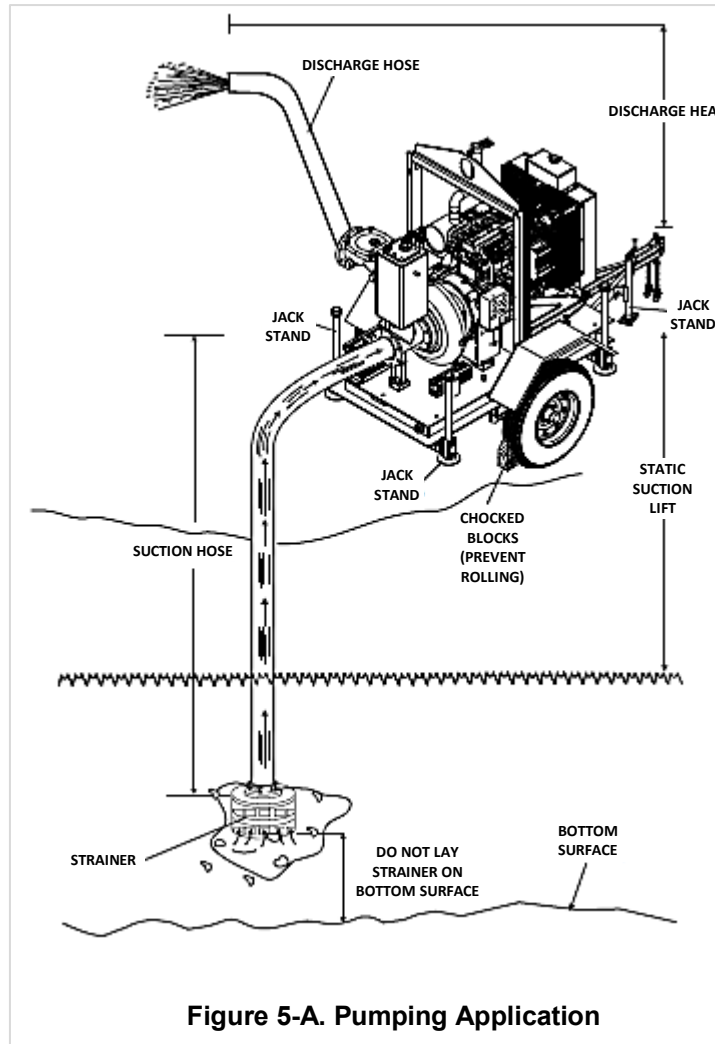

Figure 5-A. Pumping Application

Figure 5-A shows a typical application using the Dry Prime diesel-powered prime-assist pump. Please note that this pump is intended for the removal of clean water and water containing some debris and solids. Maximum size of solids should not exceed 3 inches (76.2 mm) in diameter. **Do Not** set strainer on bottom of water bed.

Placing the strainer above the water bed will prevent the pump from drawing in excessive amounts of sand and foreign debris.

The following terms are usually used when referring to lift or head:

Static Suction Lift – The vertical distance from the water line to the center of the impeller.

Static Discharge Head – The vertical distance from the discharge outlet to the point of discharge or liquid level when discharging into the bottom of a water tank.

Dynamic Suction Head – The static suction lift plus the friction in the suction line. Also referred to as total suction head.

Dynamic Discharge Head – The static discharge head plus the friction in the discharge line. Also referred to as total discharge head.

Total Dynamic Head – The Dynamic Head Suction Head plus the Dynamic Discharge Head. Also referred to as total head.

Towing Application

NOTICE

Reference *Trailer Safety Guidelines* section in this manual for a more detailed complete understanding on towing requirements.

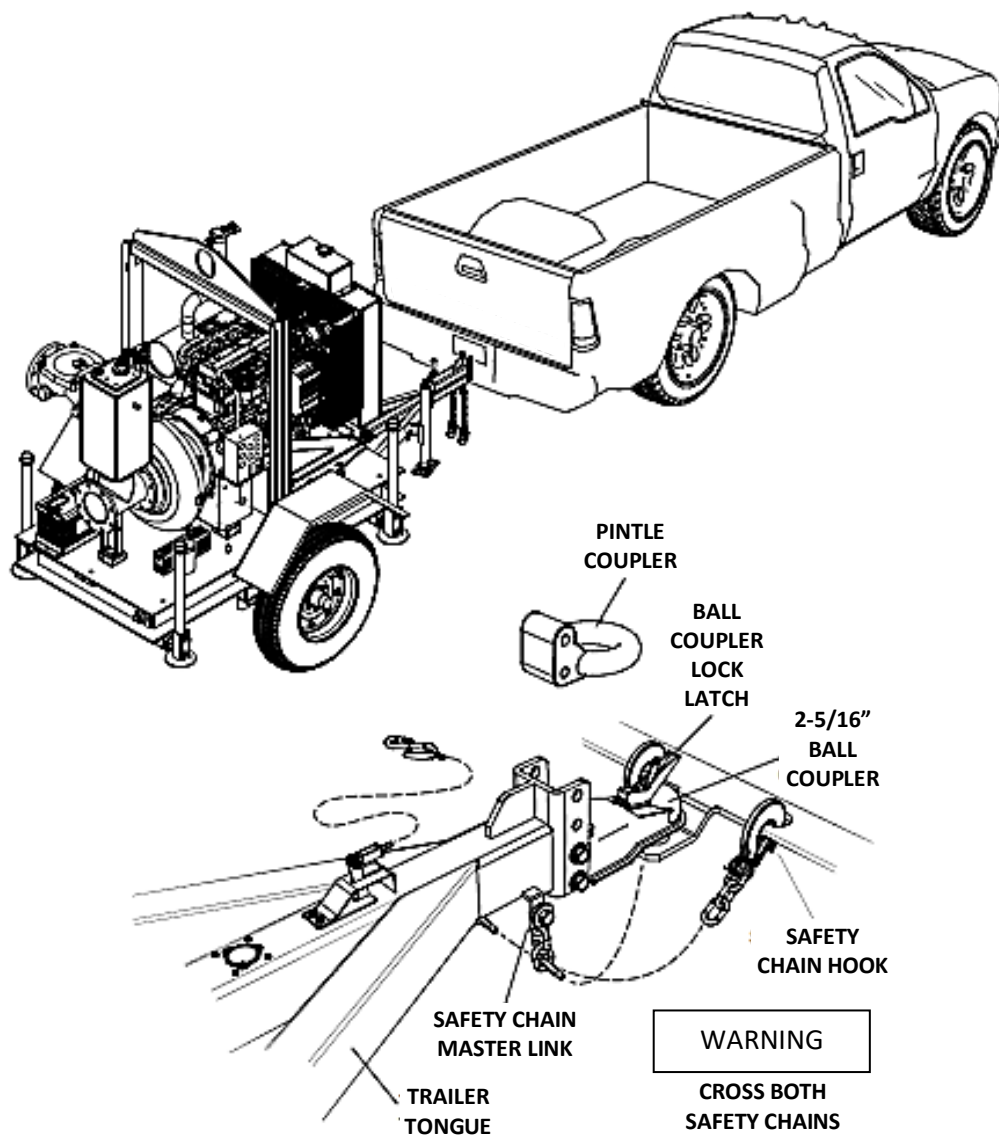

Figure 5-B. Towing Application

Pump Maintenance

To ensure longer pump life and service, please follow the pump maintenance guidelines as listed in Table 6A below.

Table 6A – Pump Maintenance	
Daily	Check bearing grease fittings
	Check mechanical seal grease fitting
	Check for leaks and kinks in discharge hose.
	Check pump volute. Flush with clean water.
	Check strainer.
Every 250 hours	Check tire pressure
	Inspect protective guards
	Inspect all nuts and bolts
	Check/replenish bearing grease
	Check/replenish mechanical seal grease
	Check condition of discharge check valve
	Inspect/clean venturi
	Check jack stands
	Check tire pressure
	Check wheel bearings
	Check safety chains
	Check trailer hitch
	Check lights
Check/tighten wheel lugs	

- Shut off the engine and check the vacuum reading. The vacuum reading should be 0.75 to 0.9 bar, or 25 to 27 inches hg. Vacuum reading should hold about 3 to 10 minutes before dropping to zero.
- If the vacuum reading drops fast, check for leaks and repair if necessary. Listen for leaks. If the area is quiet, small air leaks should be easy to hear.

NOTICE

The vacuum test will indicate the condition on the impeller and wear ring. If this test fails, the pump must be disassembled, and the impeller and wear ring must be inspected for wear and clearance tolerances. Reference replacing the impeller procedure in the maintenance section of this manual.

Dry Pump Vacuum Test

- To perform the pump vacuum test do the following:
- Perform all start-up steps without installing the hoses.
- Block the suction with a plug or heavy rubber flap as shown in Figure 6-A. An accurate vacuum gauge should be installed in the plug or flap to check the vacuum system performance and pump vacuum gauge.
- Place the ball valve on side of suction chamber in the **closed** position. This will isolate the venturi.
- Start the engine and run at 1800 RPM. Note the maximum vacuum reading.

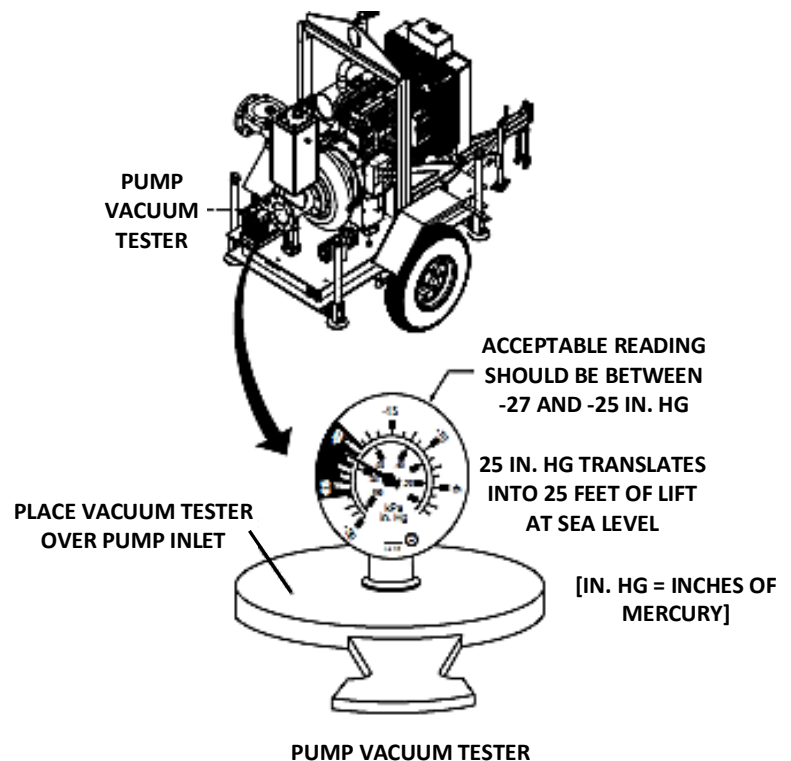

Figure 6-A. Dry Pump Vacuum Test

NOTICE

Before attempting any maintenance procedures on the pump, **always** disconnect the negative battery cable from the battery.

Refer to the **Pump End Assembly** drawing in the parts section of this manual for item numbers referenced in the maintenance procedures shown below and on the preceding pages.

Pump Flushing

NOTICE

Proper pump care requires that the pump volute chamber be flushed with clean fresh water, to ensure that no corrosive liquids or potentially damaging particles are left inside the pump during idle periods.

1. Remove the vent plugs (Figure 6-B) from the volute.

Item No.	Description
1	Volute
2	Plug

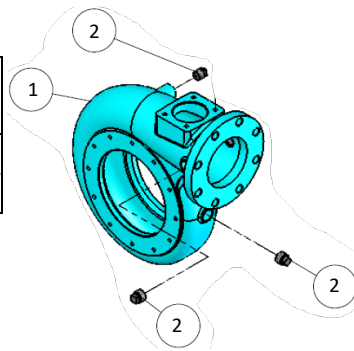
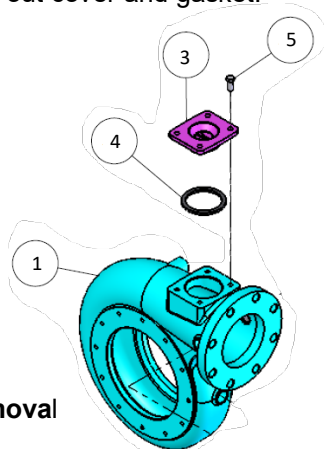

Figure 6-B. Plug Removal

2. Remove the four bolts that secure the clean-out cover (Figure 6-C) to the volute.
3. Remove the clean-out cover and gasket.

Item No.	Description
1	Volute
3	Clean-out Cover
4	Gasket
5	Bolt



**Figure 6-C
Clean-out Cover Removal**

4. Place the volute drain valve (Figure 6-D) in the **open** position.

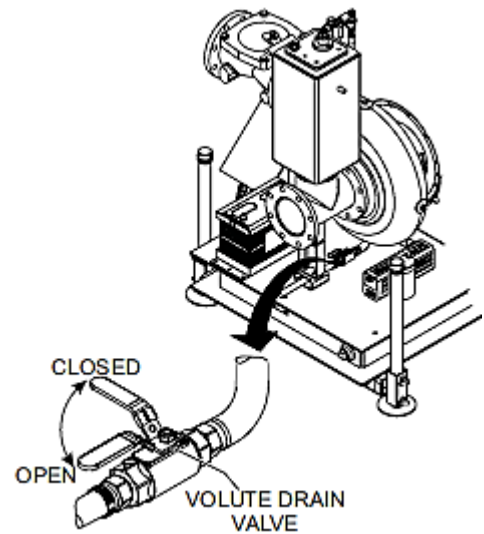

Figure 6-D. Volute Drain Valve (Open)

5. Flush the pump from the discharge side, using a high velocity stream of fresh water.
6. Continue flushing until clear water comes out of each drain plug, especially the bottom drain valve.
7. Reinstall all of the vent plugs.
8. Reinstall the gasket and cleanout cover on the volute. (Replace the gasket with a new one if the existing one is damaged.)
9. Place the volute drain valve in the **closed** position.

Testing the Venturi Nozzle

- Using a flat blade screw driver, disconnect the hose (Figure 6-E) connected to the suction chamber ball valve.

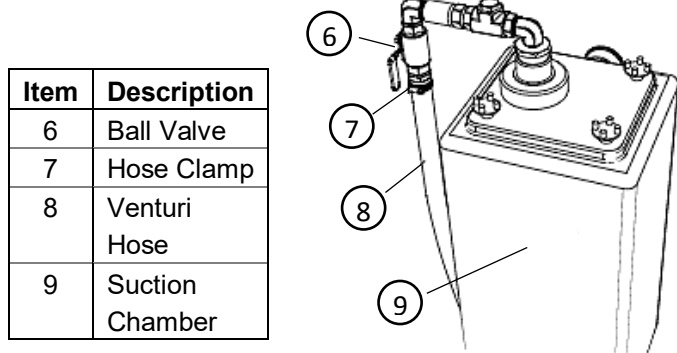

Figure 6-E. Venturi Hose Disconnection

- Attach a 0 to 30 inch vacuum gauge to the free end of the venturi hose as shown in Figure 6-F.

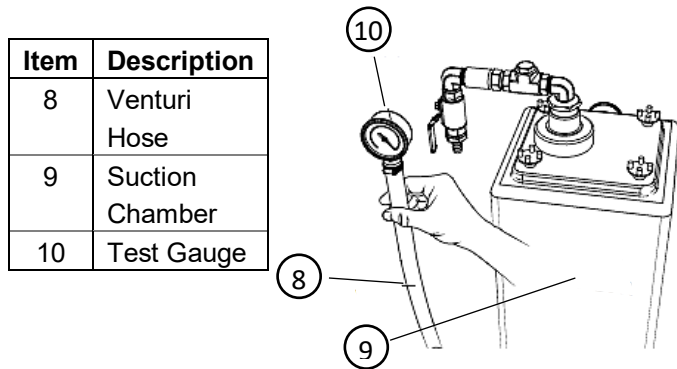

Figure 6-F. Vacuum Gauge

- Start the engine. The test gauge should read 25 inches Hg.
- If the vacuum reads 25 inches or higher, then it can be assumed the venturi is working correctly.
- Stop the engine. Remove the gauge and reconnect the venturi hose to the suction chamber ball valve.

Checking Operation of Float Assembly

- Remove the four wrench nuts (Figure 6-G) from the top of the suction chamber.

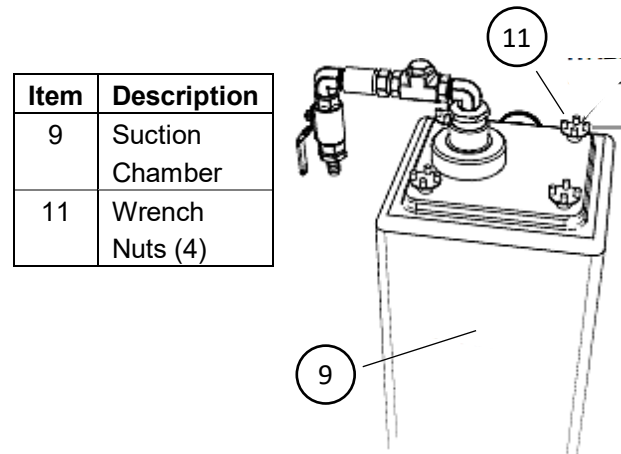

Figure 6-G. Wrench Nut Removal

- Carefully remove the float assembly and place it on top of the suction chamber as shown in Figure 6-H.

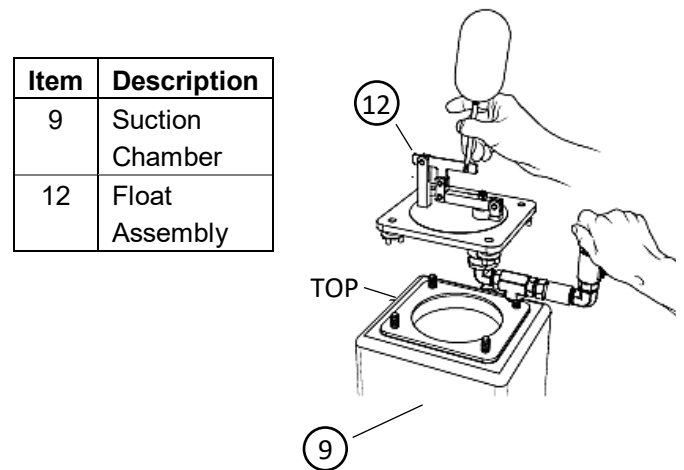

Figure 6-H. Float Assembly Removal

3. Measure the gap between points “A” and “B” as shown in Figure 6-J. This is done with the float causing the rubber bumper to rest lightly against the seat.

Item	Description
13	Float
14	Adjustment Screw
15	Locking Nut
16	Rubber Bumper

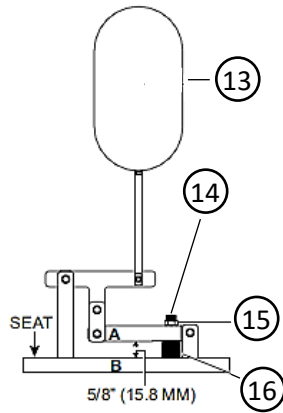

Figure 6-J. Float Adjustment

4. To set gap, loosen the locking nut and turn the adjustment screw until 5/8-inch (15.8 mm) length clearance is achieved. Replace the rubber bumper if necessary to obtain this clearance.
5. Tighten the locking nut.
6. Carefully reinstall the float assembly back inside the suction chamber.
7. Reinstall the four wrench nuts on top of the suction chamber. Hand tighten the wrench nuts snugly.

Engine Maintenance

The following information regarding engine maintenance provides only a high level view of recommended practices. Please refer to the engine manufacturer's O&M Manual for complete instructions.

Maintenance Guidelines - Overview

General Information

Cummins Inc. recommends that the system be maintained according to the Maintenance Schedule in this section.

If the system is operating in ambient temperatures below -18°C [0°F] or above 38°C [100°F], perform maintenance at shorter intervals. Shorter maintenance intervals are also required if the system is operated in a dusty environment or if frequent stops are made. Contact your local Cummins® Authorized Repair Location for recommended maintenance intervals.

Some of these maintenance procedures require special tools or must be completed by qualified personnel. Contact your local Cummins® Authorized Repair Location for detailed information.

If your system is equipped with a component or accessory not manufactured or supplied by Cummins Inc., refer to the component manufacturer's maintenance recommendations.

OEM supplied equipment and components can impact on the performance and reliability of the engine if they are not correctly maintained.

Maintenance Schedule

General Information

Cummins Inc. recommends that the engine be maintained according to the Maintenance Schedule in this section.

NOTE: The maintenance intervals **must** be reduced if the engine is operating in ambient temperatures consistently below -18°C [0°F], dusty environment or frequent start and stop operations. Contact a Cummins® Authorized Repair Location for recommended intervals.

Keep a record of all performed maintenance.

If engine is equipped with a component or an accessory **not** manufactured by Cummins Inc., refer to the original equipment manufacturer (OEM) service manual and maintenance recommendations.

Perform maintenance at whichever interval occurs first. At each scheduled maintenance interval, perform all previous maintenance checks that are due for scheduled maintenance.

Specific instructions for performing the maintenance checks are listed in the sections below:

Maintenance Procedures at Daily Interval

- Crankcase Breather Tube - Check
- Lubricating Oil Level - Check
- Fuel-Water Separator - Drain
- Fan, Cooling - Check
- Coolant Level - Check
- Air Intake Piping - Check
- Air Cleaner Restriction - Check⁽³⁾
- Dust Ejection Valve - Check
- Drive Belts - Check

Maintenance Procedures at 250 Hours or 3 Months

- Lubricating Oil and Filters - Change⁽¹⁾
- Radiator Hoses - Check
- Charge Air Cooler - Check
- Charge Air Piping - Check
- Air Intake Piping - Check

Maintenance Procedures at 500 Hours or 6 Months

- Fuel-Water Separator - Change
- Fuel Filter (Cartridge Type) - Change
- Lubricating Oil and Filters - Change⁽¹⁾
- Radiator Pressure Cap - Check
- Engine Coolant Antifreeze - Check
- Batteries - Check
- Battery Cables and Connections - Check

Maintenance Procedures at 1000 Hours or 1 Year

- Fan Hub, Belt Driven - Check
- Cooling Fan Belt Tensioner - Check

Maintenance Procedures at 2000 Hours or 2 Years

- Overhead Set - Adjust
- Cooling System - Flush⁽²⁾

Notes:

1 Oil change interval for engines equipped with an 8.2 liter [8.6 quart] lubricating oil pan capacity is every 500 hours or 6 months.

2 **Must** use a heavy-duty year-around antifreeze that meets the chemical composition of American Society of Testing and Materials (ASTM) D6210 standard.

3 The air cleaner (filter) element change interval is based upon restriction. It is important to check the restriction daily and change the primary air cleaner filter(s) once they become restricted (635 mm-h₂o [25 in-h₂o]). The secondary air cleaner filters should be changed every third time the primary filters are changed. If the primary filter has been breached during vehicle operation, the secondary filter should be changed, if necessary.

Daily Maintenance Procedures – Overview

General Information

Preventive maintenance begins with day-to-day awareness of the system. Before starting the system, check the appropriate fluid levels. Look for:

- Leaks
- Loose or damaged parts
- Worn or damaged belts
- Worn or damage low and high voltage harnesses
- Any change in system appearance.
- Odor of fuel
- Odor of electronic devices

System Operation Report

The system must be maintained in top mechanical and electronic condition if the operator is to get optimum satisfaction from its use. The maintenance department needs daily running reports from the operator to make necessary adjustments in the time allocated. The daily running report also helps to make provisions for more extensive maintenance work as the reports indicate the necessity.

Comparison and intelligent interpretation of the daily report, along with a practical follow-up action, will eliminate most failures and emergency repairs.

Report to the maintenance department any of the following conditions that may apply:

- Low lubricating oil pressure
- Low power
- Power increases or engine surge
- Erratic or no accelerator control or response
- Any warning lights flashing or staying on
- Abnormal water or oil temperature
- Unusual system noise
- Excessive smoke
- Excessive use of coolant, fuel, or lubricating oil
- Any fuel, coolant, or lubricating oil leaks
- Loose or damaged parts
- Worn or damaged belts
- Worn or damaged low or high voltage harnesses

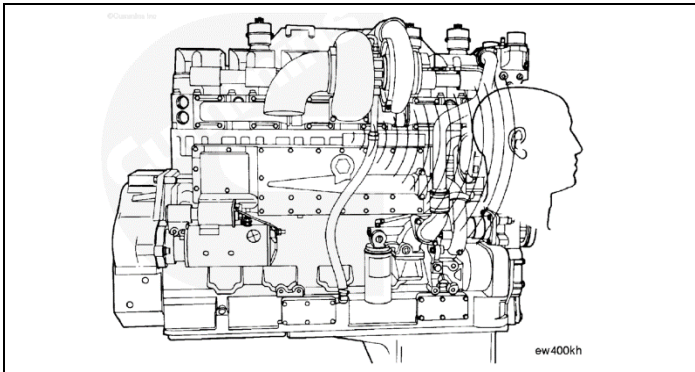

Unusual System Noise

During daily maintenance checks, listen for any unusual system noise(s) that can indicate that service is required.

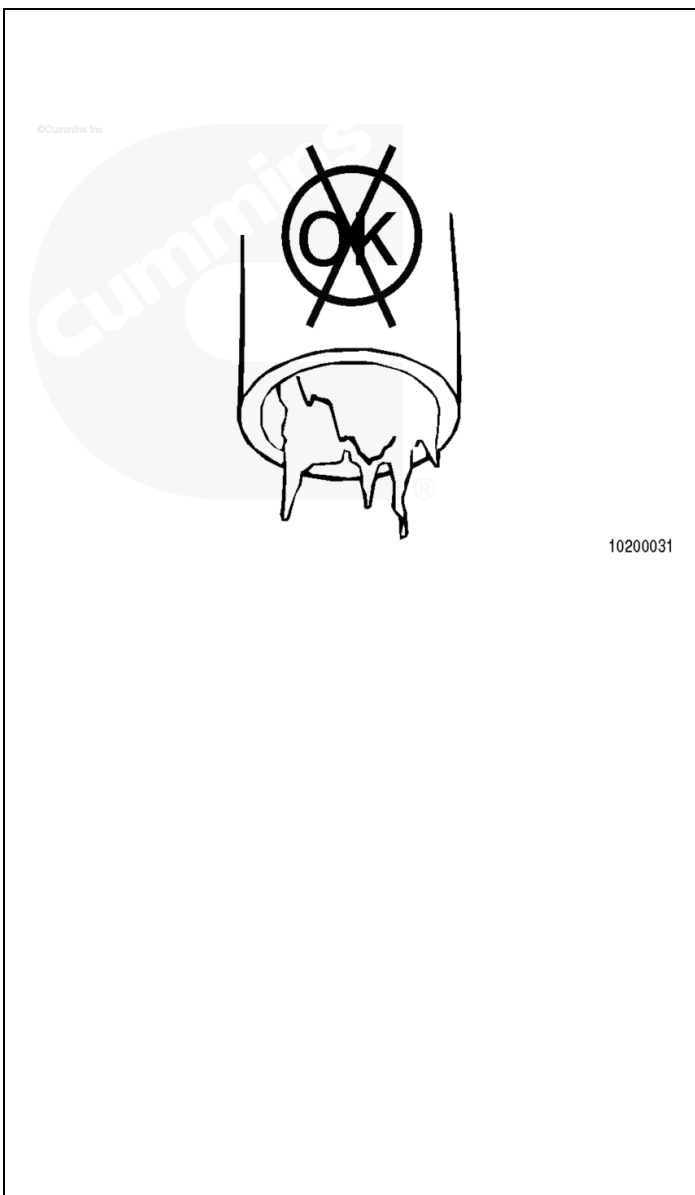

Crankcase Breather Tube Maintenance Check

If equipped, drain the catch bottle and properly dispose of contents.

Inspect the crankcase breather tube outlet for the following conditions that may be blocking or restricting the crankcase breather tube.

NOTE: If equipped with a catch bottle at the end of the crankcase breather tube, removal of the catch bottle may be required to inspect the crankcase breather tube outlet.

- Sludge
- Debris
- Ice.

If any of the above conditions exist, the crankcase breather tube outlet **must** be cleaned.

Inspect the crankcase breather tube outlet more frequently when ambient temperatures are below freezing. Frequent ice buildup in the crankcase breather tube may require one of the following actions.

- A crankcase breather tube heater option be installed.
- If a crankcase breather tube heater is already installed, troubleshoot the crankcase breather tube heater for not operating.

Contact a Cummins® Authorized Repair Location.

**Crankcase Breather Tube
Maintenance Check**

Visually inspect the crankcase breather tube for the following conditions.

- Cracks
- Material deterioration
- General damage.

If any of the above conditions are exist, replace the crankcase breather tube. Contact a Cummins® Authorized Repair Location.

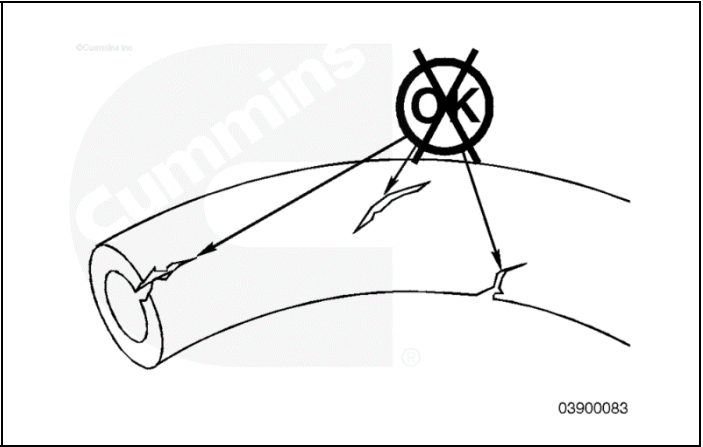

**Lubricating Oil Level
Maintenance Check**

CAUTION

Never operate the engine with oil level below the L (low) mark or above the H (high) mark. Poor engine performance or engine damage can occur.

The engine **must** be level when checking the oil level to make sure the measurement is correct.

Shut off the engine for an accurate reading.

Wait at least 15 minutes after shutting off the engine to check the oil level. This allows time for the oil to drain into the oil pan.

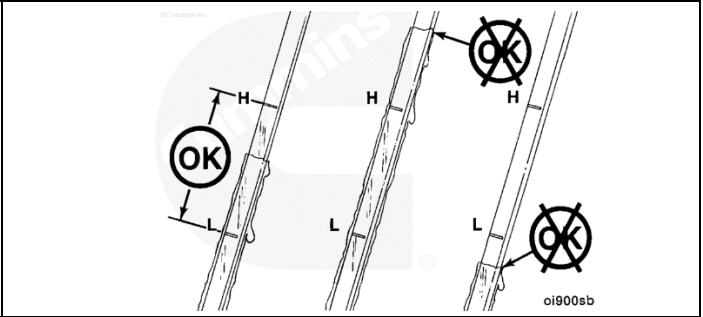

**Fuel-Water Separator
General Information**

Fuel System Priming

A certain amount of air becomes trapped in the fuel system when fuel system components on the supply and/or high-pressure side are serviced or replaced. Fuel system priming is accomplished using a manual priming pump. For priming procedures, see the Prime section of this procedure.

NOTE: It is **not** necessary to vent air from the high-pressure fuel system before starting the engine. Cranking the engine will help prime the fuel system.

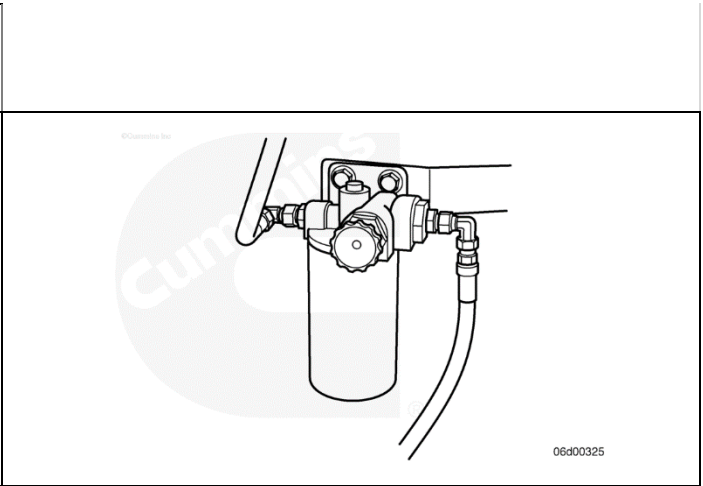

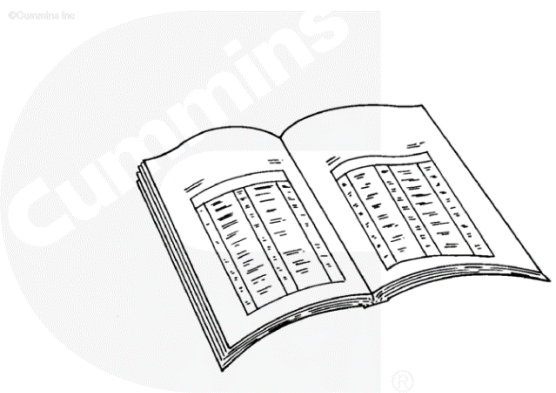
 <p>©Cummins Inc.</p> <p>ck800wa</p>	<p>Preparatory Steps</p>
	<p>WARNING</p>
	<p>Fuel is flammable. Keep all cigarettes, flames, pilot lights, arcing equipment, and switches out of the work area and areas sharing ventilation to reduce the possibility of severe personal injury or death when working on the fuel system.</p>
	<p>WARNING</p>
	<p>Do not bleed the fuel system of a hot engine; this can result in fuel spilling onto a hot exhaust manifold, which can cause a fire.</p>
	<p>WARNING</p>
<p>Batteries can emit explosive gases. To reduce the possibility of personal injury, always ventilate the compartment before servicing the batteries. To reduce the possibility of arcing, remove the negative (-) battery cable first and attach the negative (-) battery cable last.</p>	
<p>WARNING</p>	
<p>Wear appropriate eye and face protection when using compressed air. Flying debris and dirt can cause personal injury.</p>	
<p>WARNING</p>	
<p>When using a steam cleaner, wear safety glasses or a face shield, as well as protective clothing. Hot steam can cause serious personal injury.</p>	
<ul style="list-style-type: none"> ▪ Disconnect the batteries. See equipment manufacturer service information. ▪ Clean the area around the fuel filter. ▪ If required, disconnect the wiring harness from the water-in-fuel sensor. <p>NOTE: Clean all around the filter area before disassembly. Dirt or contaminants can damage the fuel system.</p>	

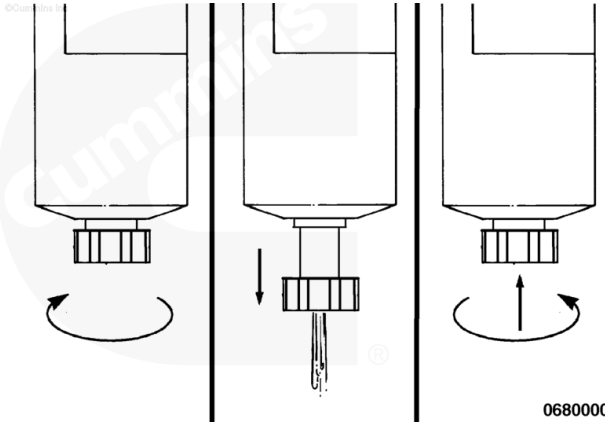
<p>Drain</p> <p>⚠ WARNING</p> <p>Drain the water-fuel separator into a container and dispose of the accordance with local environmental regulations.</p> <p>⚠ CAUTION</p> <p>When closing the drain valve, do not overtighten the valve. Overtightening can damage the threads.</p> <p>Cummins Inc. requires a water-fuel separator or fuel filter be installed in the fuel supply system.</p> <p>Drain the water and sediment from the water-fuel separator daily.</p> <p>Open the drain valve by hand. Turn the valve counterclockwise approximately 3 1/2 turns until the valve drops down 25 mm [1 in] and draining occurs.</p> <p>Drain the filter sump until clear fuel is visible.</p> <p>To close the valve, lift the valve and turn clockwise until it is hand-tight.</p>	 <p>06800004</p>
--	---

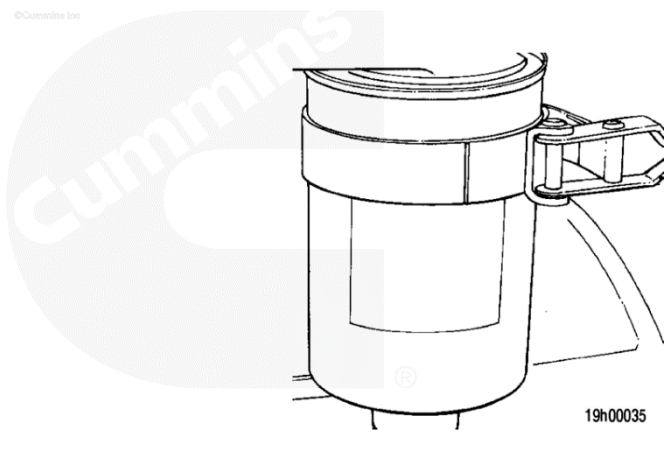
<p>Remove</p> <p>Remove the fuel-water separator from the filter head with filter wrench, Part Number 3398231, or equivalent.</p>	 <p>19h00035</p>
--	--

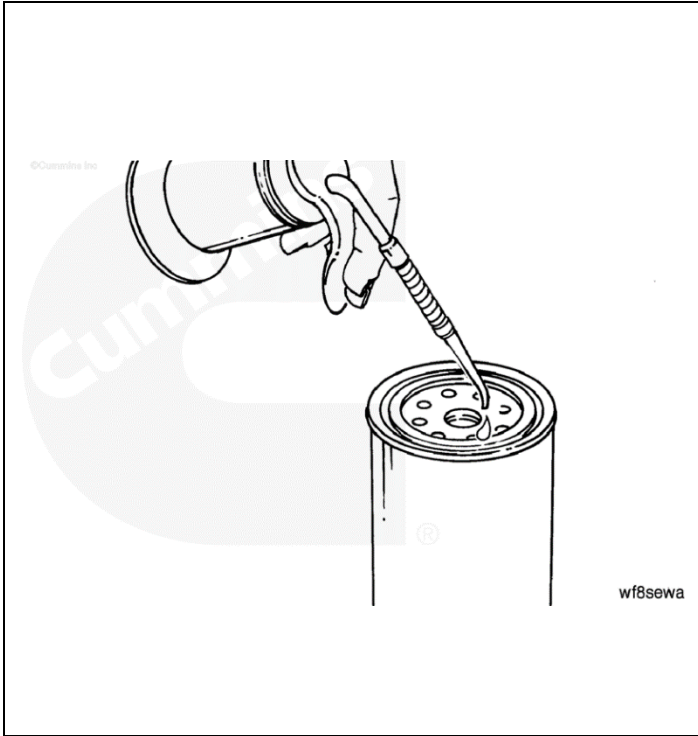

Install

CAUTION

Do not pre-fill the suction side fuel filter with fuel unless a clean side block off plug is used. The system must be primed after the fuel filter is installed. Pre-filling the pressure side fuel filter can result in debris entering the fuel system and damaging fuel system components.

NOTE: If available, pre-fill new filters, with clean fuel prior to assembly using the clean side block-off plug packed with the filter. Do not pour fuel directly into the center of the filter as this will allow unfiltered fuel to enter the system and can cause damage to fuel system components.

Use the correct fuel filter.

Lubricate the fuel filter o-ring seal with clean lubricating oil.

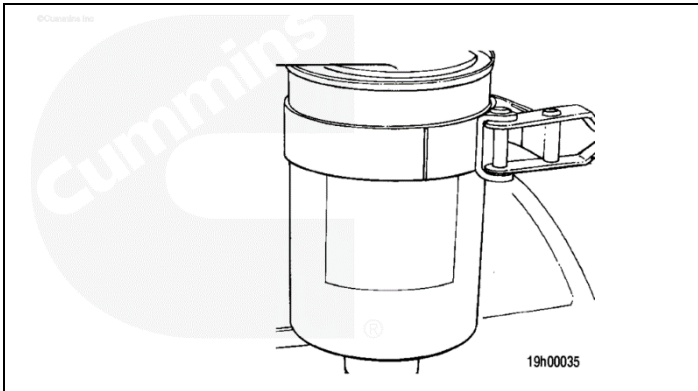

Install the fuel-water separator from the filter head with filter wrench, Part Number 3398231, or equivalent.
Torque Value: 24 N•m [204 in-lb]

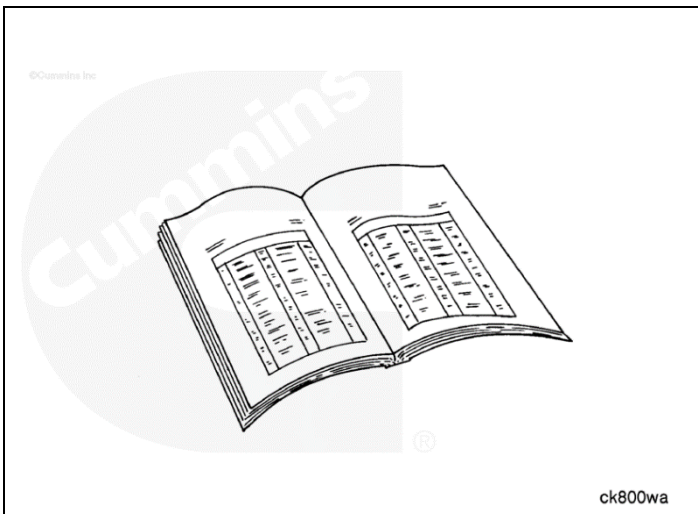

Finishing Steps

WARNING

Batteries can emit explosive gases. To reduce the possibility of personal injury, always ventilate the compartment before servicing the batteries. To reduce the possibility of arcing, remove the negative (-) battery cable first and attach the negative (-) battery cable last.

- If required, connect the wiring harness to the water-in-fuel sensor.
- Connect batteries. See equipment manufacturer service information.

Operate the engine and check for leaks.

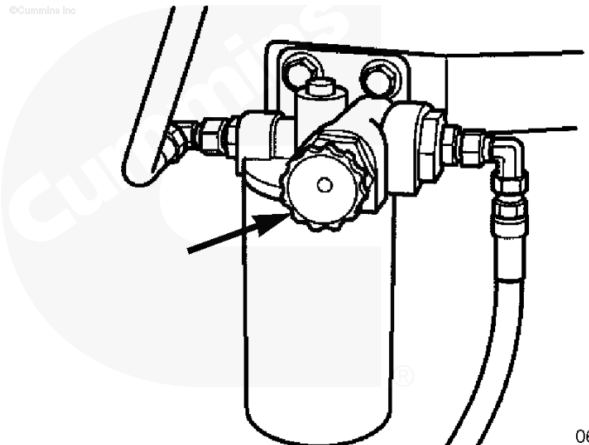
<p>Prime</p> <p>WARNING</p> <p>The fuel pump, high-pressure fuel lines, and fuel rail contain very high-pressure fuel. To reduce the possibility of personal injury, never loosen any fittings while the engine is running.</p> <p>CAUTION</p> <p>Do not engage the starter motor for more than 30 seconds at a time. Allow two minutes between cranking intervals.</p>	
<p>After a fuel-water separator change or running the vehicle tank dry, make sure there is fuel in the vehicle fuel tank.</p> <p>NOTE: It is not necessary to vent air from the high-pressure fuel system before starting the engine. Cranking the engine will prime the fuel system.</p> <p>Unlock the manual priming pump handle by turning counterclockwise. Pump the primer handle until resistance is felt and the handle can not be pumped any longer (approximately 140 to 150 strokes for dry filters, or 20 to 60 strokes for pre-filled filters).</p> <p>Lock the manual priming pump handle.</p> <p>Crank the engine. If the engine does not start after 30 seconds, turn the keyswitch to the OFF position.</p> <p>Pump the priming pump again, repeating the previous steps until the engine starts.</p> <p>When the engine does start, it may run erratically and with increased noise levels for a few minutes. This is a normal condition.</p> <p>If the engine does not start, contact a Cummins Authorized Repair Location.</p> <p>Operate the engine and check for leaks.</p>	 <p>06d00409</p>

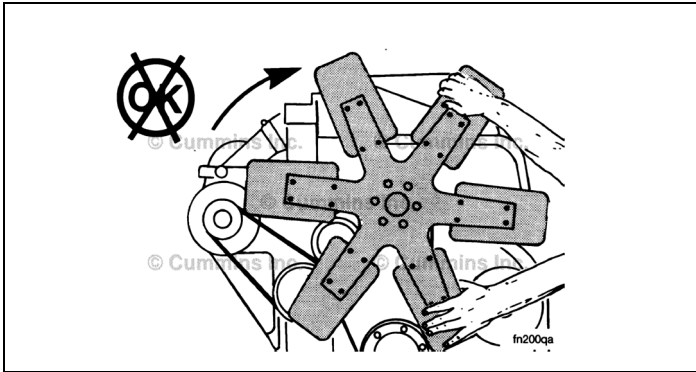

Fan, Cooling
Inspect for Reuse

WARNING

Do not pull or pry on the fan to manually rotate the engine. To do so can damage the fan blades. Damaged fan blades can cause premature fan failures which can result in serious personal injury or property damage.

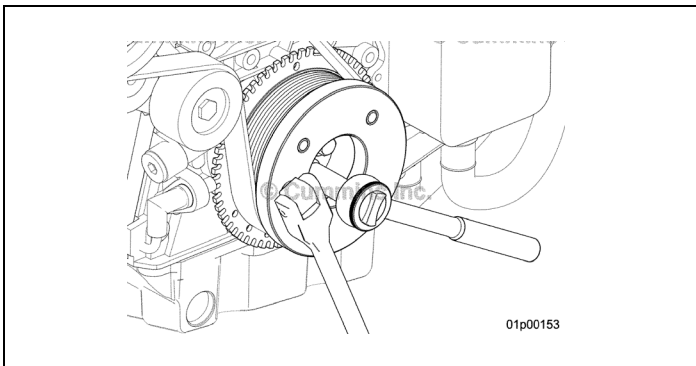

Use barring/holding tool, Part Number 5299566, to rotate the crankshaft.

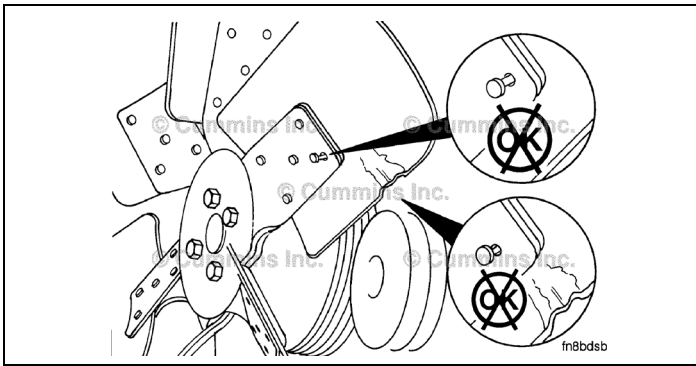

A visual inspection of the cooling fan is required daily. Check for cracks, loose rivets, and bent or loose blades. Check the fan to make sure it is securely mounted. Tighten the capscrews, if necessary.

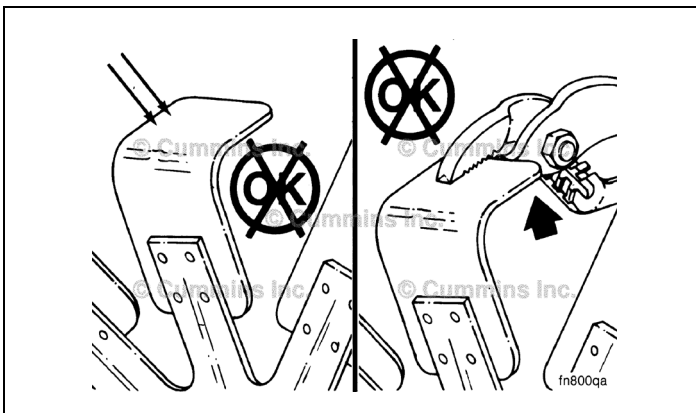

WARNING

Do not straighten a bent fan blade or continue to use a damaged fan. A bent or damaged fan blade can fail during operation and cause personal injury or property damage.

Replace original equipment fan that is damaged with a fan of the identical part number. Cummins Inc. must approve any other fan changes to be covered under warranty.

Refer to the vehicle or equipment manufacturer's specifications for capscrew torque.

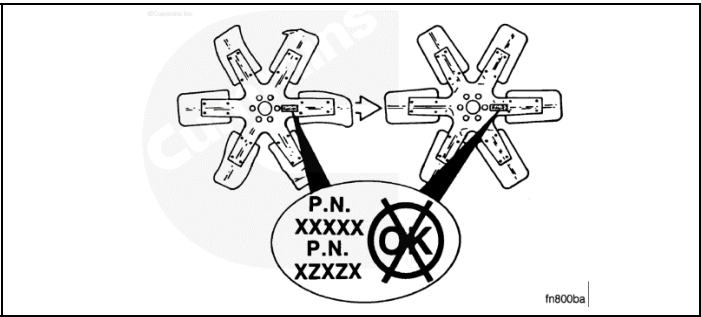

Coolant Level Maintenance Check

WARNING

Do not remove a pressure cap from a hot engine. Wait until the coolant temperature is below 50°C [120°F] before removing the pressure cap. Heated coolant spray or steam can cause personal injury.

CAUTION

Never use a sealing additive to stop leaks in the cooling system. This can result in cooling system plugging and inadequate coolant flow, causing the engine to overheat.

The coolant level **must** be checked daily.

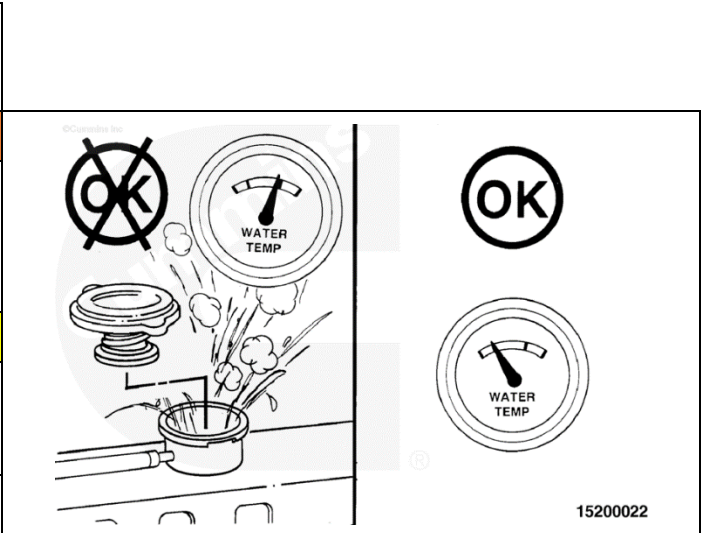

CAUTION

Do not add cold coolant to a hot engine. Engine castings can be damaged. Allow the engine to cool to below 50°C [120°F] before adding coolant.

Coolant added to the engine must be mixed with the correct proportions of antifreeze, supplemental coolant additive, and water to avoid engine damage.

Coolant recommendations and specification details on correct mixing of coolant can be found in Maintenance Specifications.

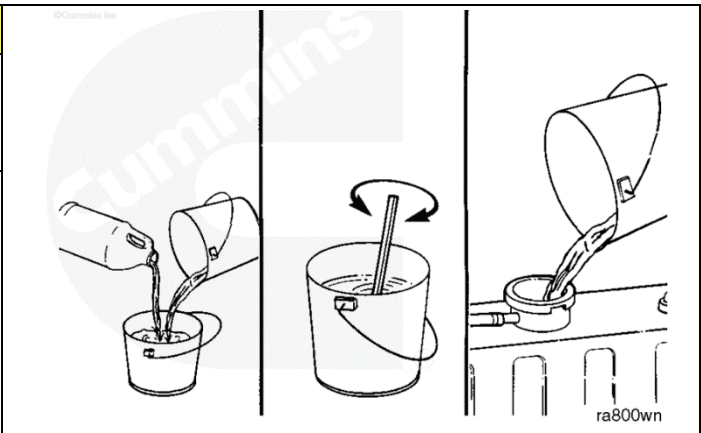

Fill the cooling system with coolant. Refer to the markings on the radiator or expansion tank for coolant levels or refer to the OEM manual.

NOTE: Some radiators have two fill necks, both of which must be filled when the cooling system is drained.

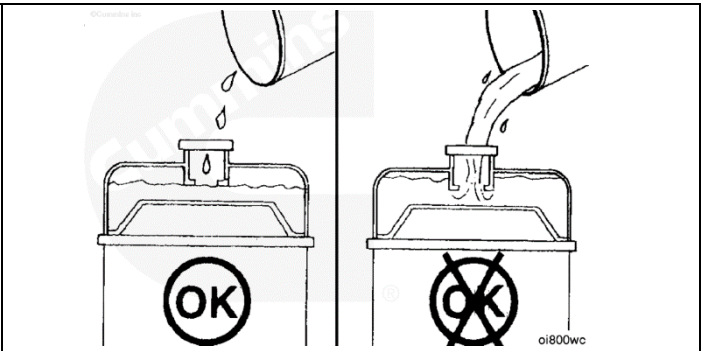

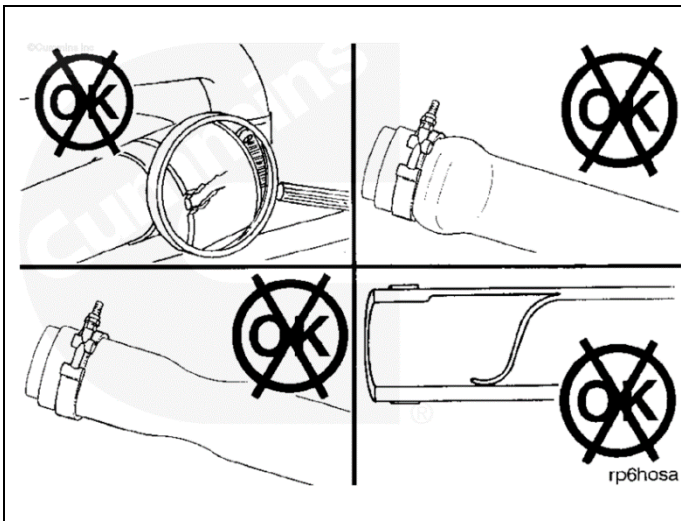

Air Intake Piping

Maintenance Check

Inspect the intake piping daily for wear points and damage to piping, loose clamps, and punctures that can damage the engine.

Replace damaged pipes and tighten loose clamps, as necessary, to prevent the air system from leaking.

Torque Value: 8 N•m [71 in-lb]

Check for corrosion under the clamps and hoses of the intake system piping. Corrosion can allow corrosive products and dirt to enter the intake system. Disassemble and clean, as required.

Air Cleaner Restriction

Maintenance Check

Mechanical Indicator

CAUTION

Never operate the engine without an air cleaner. Intake air must be filtered to prevent dirt and debris from entering the engine and causing premature wear.

NOTE: Do not remove the felt washer from the indicator. The felt washer absorbs moisture.

A mechanical restriction indicator is available to indicate excessive air restriction through a dry-type air cleaner. This instrument can be mounted in the air cleaner outlet or on the instrument panel. The red flag (1) in the window gradually rises as the cartridge loads with dirt. After changing or replacing the cartridge, reset the indicator by pushing the reset button (2).

Restriction or vacuum indicators need to be installed as close as possible to the turbocharger air

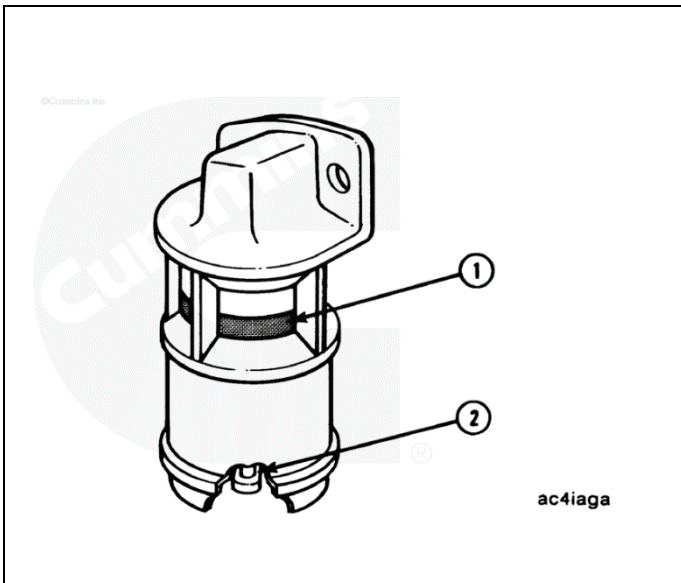

Vacuum Indicator

Vacuum switches actuate a warning light on the instrument panel when the air restriction becomes excessive.

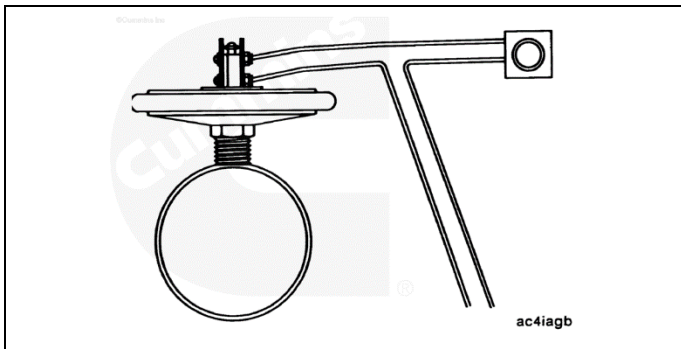

Industrial Gas Mechanical Indicator
 A mechanical restriction indicator is available to indicate excessive air restriction through a dry-type air cleaner. This instrument is mounted in the air cleaner outlet. The red flag (1) in the window gradually rises as the cartridge loads with dirt. When air restriction is indicated the air filter must be replaced. After changing or replacing the cartridge, reset the indicator by pushing the reset button (2).

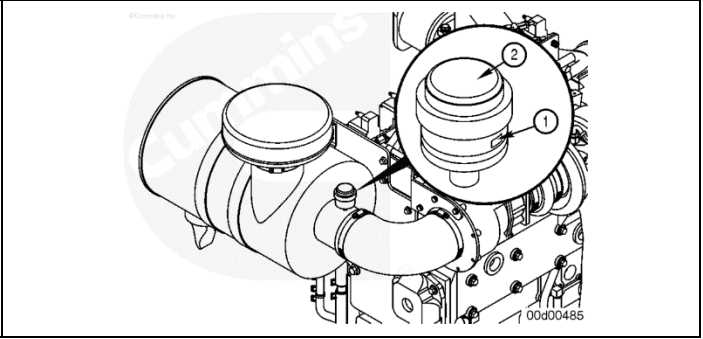

Dust Ejection Valve
Maintenance Check
 Inspect the dust ejection valve for cuts and tears. Replace the valve if damage is found.

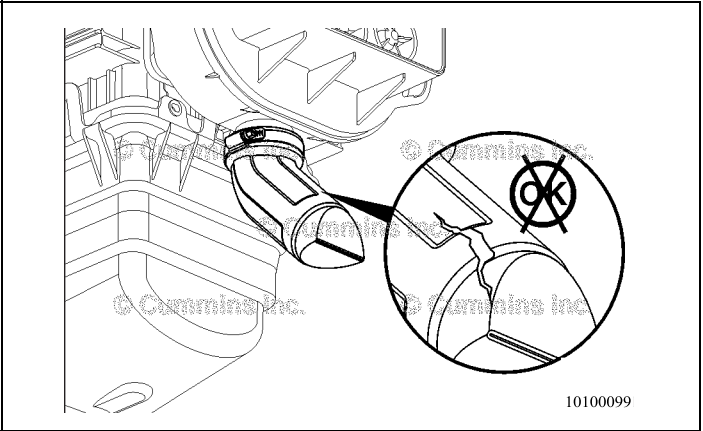

Drive Belts
Maintenance Check
Poly-Vee Belt

CAUTION

Make sure that the engine is switched off and any starting mechanisms are isolated before any inspections are made. Daily belt inspections can be carried out through an appropriate aperture. Do not remove any guards.

Inspect the belts daily. Check the belt for intersecting cracks. Traverse (across the belt width) cracks are acceptable. Longitudinal (direction of belt length) cracks that intersect with transverse cracks are **not** acceptable. Replace the belt if it is frayed or has pieces of material missing. Refer to Section A for belt adjustment and replacement procedures.

- Belt damage can be caused by:
- Incorrect tension
 - Incorrect size or length
 - Pulley misalignment
 - Incorrect installation
 - Severe operating environment
 - Oil or grease on the side of belts.

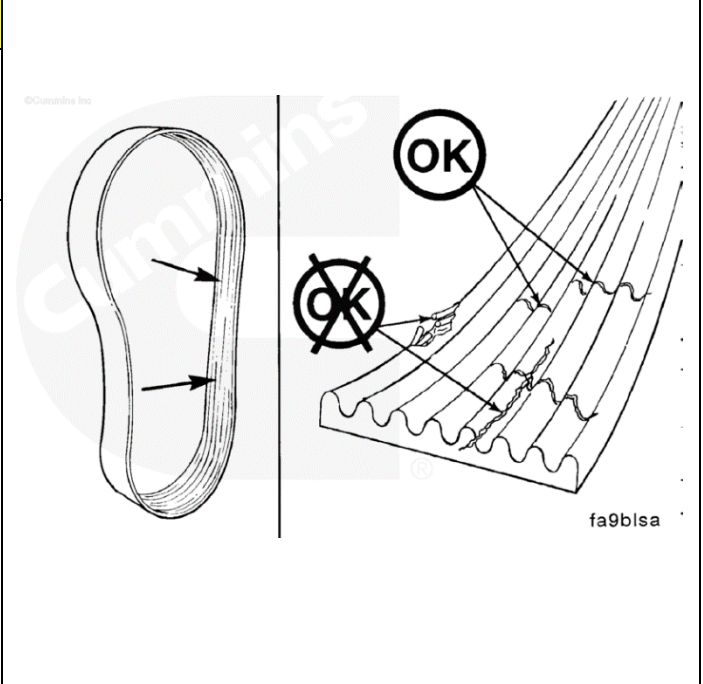

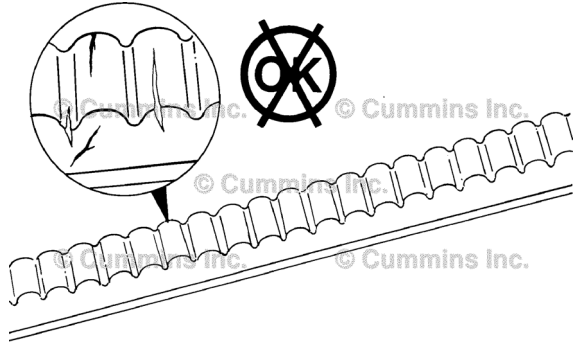
 <p>fa8blsb</p>	<p>Cogged Belt</p> <p>Inspect the belts daily. Replace the belts if they are cracked, frayed, or have chunks of material missing. Small cracks are acceptable.</p> <p>Adjust the belts that have a glazed or shiny surface, which indicates belt slippage. Correctly installed and tensioned belts will show even pulley and belt wear. Refer to Section A for belt adjustment and replacement procedures.</p> <p>Belt damage can be caused by:</p> <ul style="list-style-type: none"> • Incorrect tension • Incorrect size or length • Pulley misalignment • Incorrect installation • Severe operating environment • Oil or grease on the belts
--	---

Maintenance Procedures at 250 Hours or 3 Months

Maintenance Procedures - Overview
General Information

All maintenance checks and inspections listed in previous maintenance intervals **must** also be performed at this time, in addition to those listed under this maintenance interval.

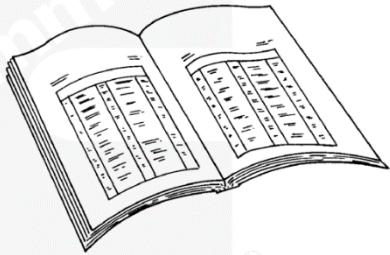
 <p>ck800wa</p>	<p>Lubricating Oil and Filters</p> <p>Drain</p> <p>WARNING</p> <p>Do not remove a pressure cap from a hot engine. Wait until the coolant temperature is below 50°C [120°F] before removing the pressure cap. Heated coolant spray or steam can cause personal injury.</p> <p>WARNING</p> <p>To reduce the possibility of personal injury, avoid direct contact of hot oil with your skin.</p> <p>Change the lubricating oil and filter(s) at the specified oil change interval. See the Maintenance Schedule to find the correct change interval for your application.</p>
--	---

Radiator Hoses
Inspect and reuse

Inspect all hoses for cracks, cuts, or collapsing. The silicone engine coolant hose will exhibit swelling because of the elasticity of the hose.

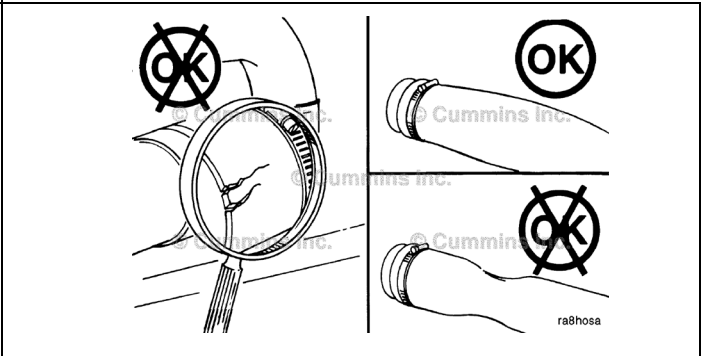

Charge-Air Cooler
Maintenance Check

Inspect the charge-air cooler (CAC) for dirt and debris blocking the fins. Check for cracks, holes, or other damage. If damage is found, refer to the vehicle, vessel, or equipment manufacturer.

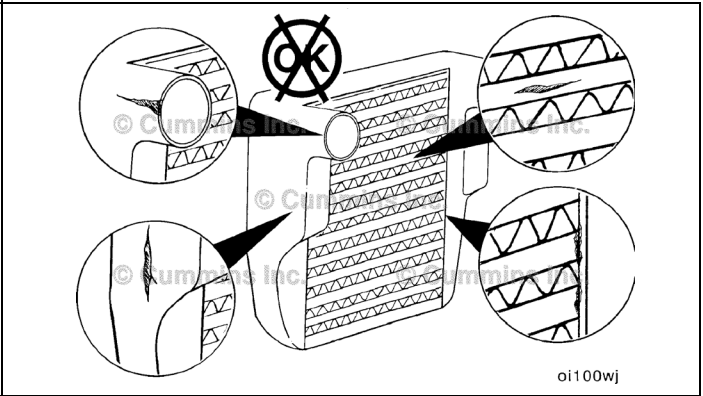

Charge-Air Piping
Maintenance Check

Inspect the charge-air piping and hoses for leaks, holes, cracks, or loose connections. Tighten the hose clamps if necessary. Refer to the vehicle or equipment manufacturer's specifications for the correct torque value.

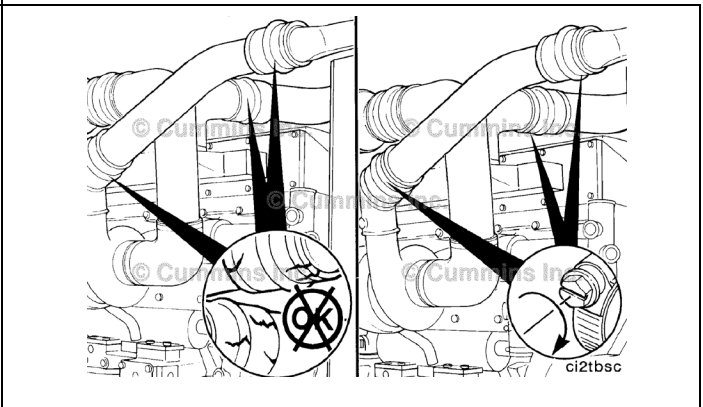

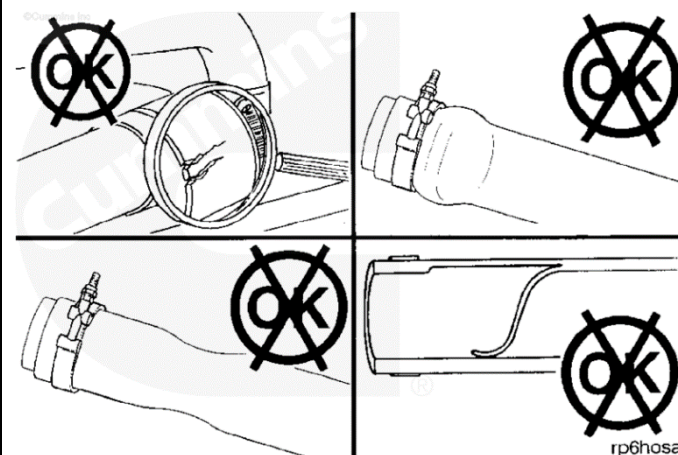
	<p>Air Intake Piping Maintenance Check</p> <p>Inspect the intake piping daily for wear points and damage to piping, loose clamps, and punctures that can damage the engine.</p> <p>Replace damaged pipes and tighten loose clamps, as necessary, to prevent the air system from leaking.</p> <p>Torque Value: 8 N•m [71 in-lb]</p> <p>Check for corrosion under the clamps and hoses of the intake system piping. Corrosion can allow corrosive products and dirt to enter the intake system. Disassemble and clean, as required.</p>
--	---

Maintenance Procedures at 500 Hours or 6 Months

	<p>Maintenance Procedures – Overview</p> <p>General Information</p> <p>All maintenance checks and inspections listed in previous maintenance intervals must also be performed at this time, in addition to those listed under this maintenance interval.</p>
--	---

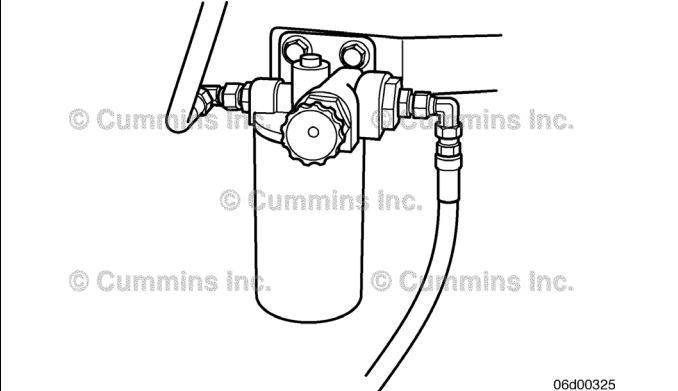
	<p>Fuel-Water Separator</p> <p>General Information</p> <p>Fuel System Priming</p> <p>A certain amount of air becomes trapped in the fuel system when fuel system components on the supply and/or high-pressure side are serviced or replaced. Fuel system priming is accomplished using a manual priming pump. For priming procedures, see the Prime section of this procedure.</p> <p>NOTE: It is not necessary to vent air from the high pressure fuel system before starting the engine. Cranking the engine will help prime the fuel system.</p>
--	--

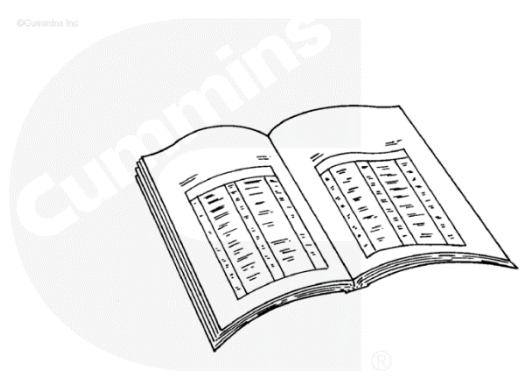
<p>Preparatory Steps</p>	 <p style="text-align: right;">ck800wa</p>
<p>⚠ WARNING</p>	
<p>Fuel is flammable. Keep all cigarettes, flames, pilot lights, arcing equipment, and switches out of the work area and areas sharing ventilation to reduce the possibility of severe personal injury or death when working on the fuel system.</p>	
<p>⚠ WARNING</p>	
<p>Do not bleed the fuel system of a hot engine; this can result in fuel spilling onto a hot exhaust manifold, which can cause a fire.</p>	
<p>⚠ WARNING</p>	
<p>Batteries can emit explosive gases. To reduce the possibility of personal injury, always ventilate the compartment before servicing the batteries. To reduce the possibility of arcing, remove the negative (-) battery cable first and attach the negative (-) battery cable last.</p>	
<p>⚠ WARNING</p>	
<p>Wear appropriate eye and face protection when using compressed air. Flying debris and dirt can cause personal injury.</p>	
<p>⚠ WARNING</p>	
<p>When using a steam cleaner, wear safety glasses or a face shield, as well as protective clothing. Hot steam can cause serious personal injury.</p>	
<ul style="list-style-type: none"> • Disconnect the batteries. See equipment manufacturer service information. • Clean the area around the fuel filter. • If required, disconnect the wiring harness from the water-in-fuel sensor. <p>NOTE: Clean all around the filter area before disassembly. Dirt or contaminants can damage the fuel system.</p>	

Drain

WARNING

Drain the water-fuel separator into a container and dispose of the accordance with local environmental regulations.

CAUTION

When closing the drain valve, do not overtighten the valve. Overtightening can damage the threads.

Cummins Inc. requires a water-fuel separator or fuel filter be installed in the fuel supply system.

Drain the water and sediment from the water-fuel separator daily.

Open the drain valve by hand. Turn the valve **counterclockwise** approximately 3 1/2 turns until the valve drops down 25 mm [1 in] and draining occurs.

Drain the filter sump until clear fuel is visible.

To close the valve, lift the valve and turn **clockwise** until it is hand-tight.

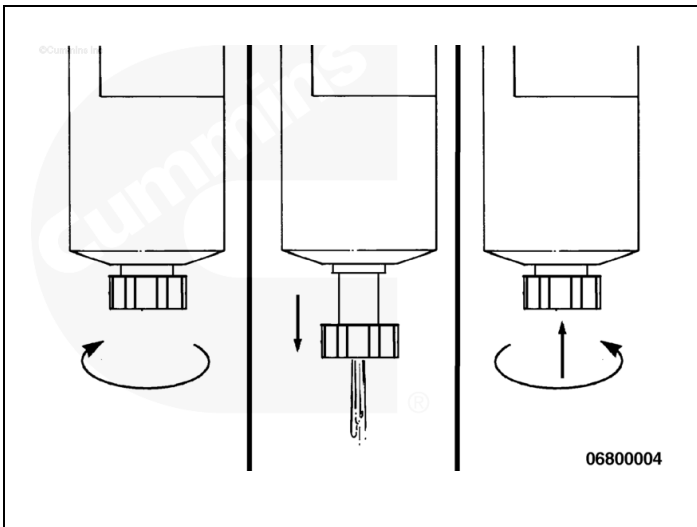

Remove

Remove the fuel-water separator from the filter head with filter wrench, Part Number 3398231, or equivalent.

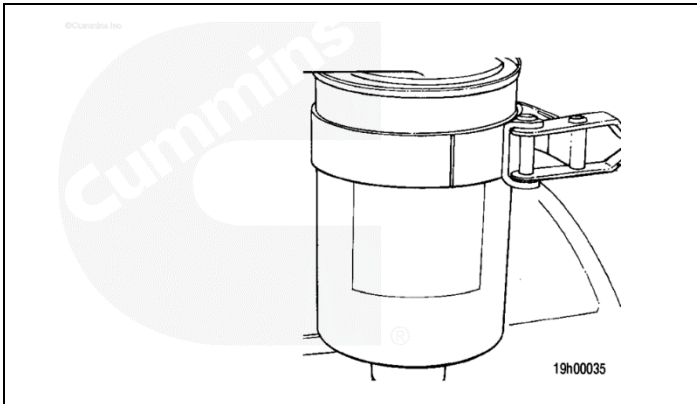

Install

⚠ CAUTION

Do not pre-fill the suction side fuel filter with fuel unless a clean side block off plug is used. The system must be primed after the fuel filter is installed. Prefilling the pressure side fuel filter can result in debris entering the fuel system and damaging fuel system components.

NOTE: If available, pre-fill new filters, with clean fuel prior to assembly using the clean side block-off plug packed with the filter. Do not pour fuel directly into the center of the filter as this will allow unfiltered fuel to enter the system and can cause damage to fuel system components.

Use the correct fuel filter.

Lubricate the fuel filter o-ring seal with clean lubricating oil.

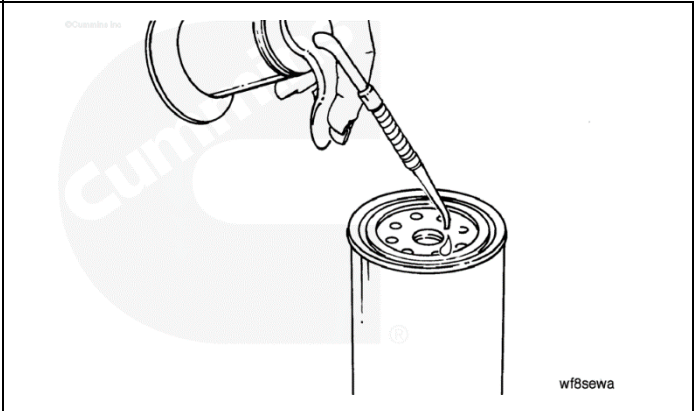

Install the fuel-water separator from the filter head with filter wrench, Part Number 3398231, or equivalent.

Torque Value: 24 N•m [204 in-lb]

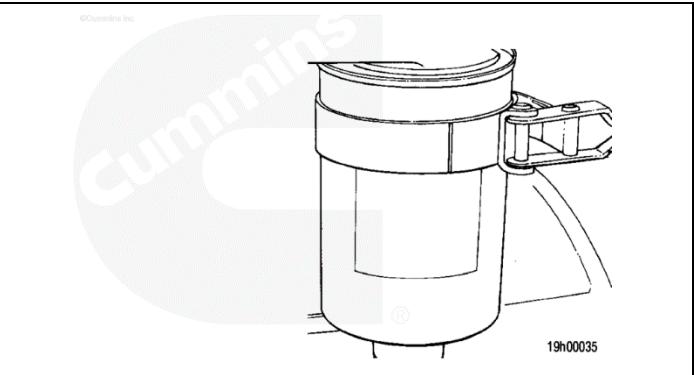

Finishing Steps

⚠ WARNING

Batteries can emit explosive gases. To reduce the possibility of personal injury, always ventilate the compartment before servicing the batteries. To reduce the possibility of arcing, remove the negative (-) battery cable first and attach the negative (-) battery cable last.

- If required, connect the wiring harness to the water-in-fuel sensor.
- Connect batteries. See equipment manufacturer service information.
- Operate the engine and check for leaks.

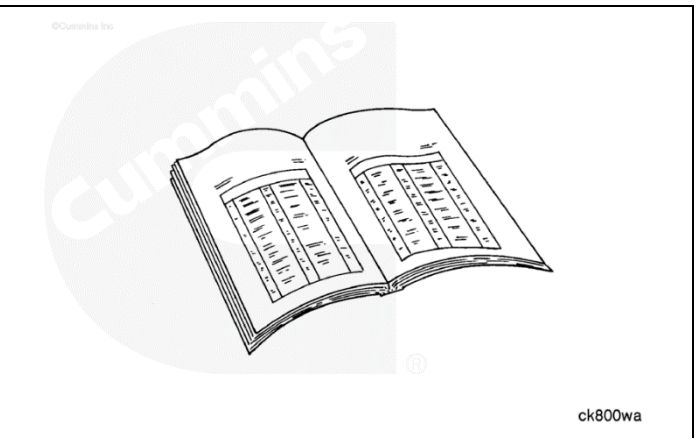

Prime

⚠ WARNING

The fuel pump, high-pressure fuel lines, and fuel rail contain very high-pressure fuel. To reduce the possibility of personal injury, never loosen any fittings while the engine is running.

⚠ CAUTION

Do not engage the starter motor for more than 30 seconds at a time. Allow two minutes between cranking intervals.

After a fuel-water separator change or running the vehicle tank dry, make sure there is fuel in the vehicle fuel tank.

NOTE: It is **not** necessary to vent air from the high pressure fuel system before starting the engine. Cranking the engine will prime the fuel system.

Unlock the manual priming pump handle by turning **counterclockwise**. Pump the primer handle until resistance is felt and the handle can **not** be pumped any longer (approximately 140 to 150 strokes for dry filters, or 20 to 60 strokes for pre-filled filters).

Lock the manual priming pump handle.

Crank the engine. If the engine does **not** start after 30 seconds, turn the keyswitch to the OFF position.

Pump the priming pump again, repeating the previous steps until the engine starts.

When the engine does start, it may run erratically and with increased noise levels for a few minutes. This is a normal condition.

If the engine does **not** start, contact a Cummins Authorized Repair Location.

Operate the engine and check for leaks.

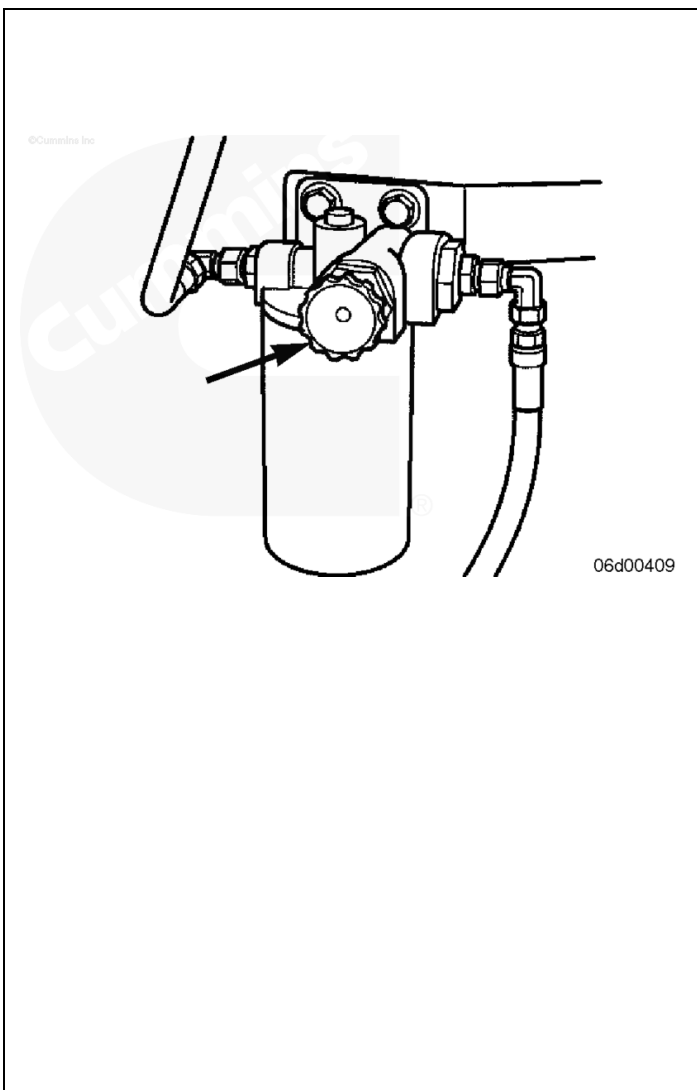

**Fuel Filter (Cartridge Type)
General Information**

The engine uses a dual suction side fuel filter system.

The main fuel filter is a cartridge type fuel filter (1) and is located between the gear pump and fuel-water separator. This filter is **not** pressurized, but operates under a vacuum.

The cartridge type fuel filter **must** have below characteristics:

- Water-separating
- 5-micron rating
- Water-in-fuel sensor with shunt resistor
- Water-drain valve
- Chassis mounted

The fuel-water separator (2) is located between the main fuel filter and the OEM fuel supply tank. Use the following procedure to service the fuel-water separator.

Use the following procedure for fuel filter recommendations.

If the engine has been allowed to run out of fuel or the fuel system has been serviced or repaired, it will be necessary to prime the fuel system. Reference the Priming step in this procedure.

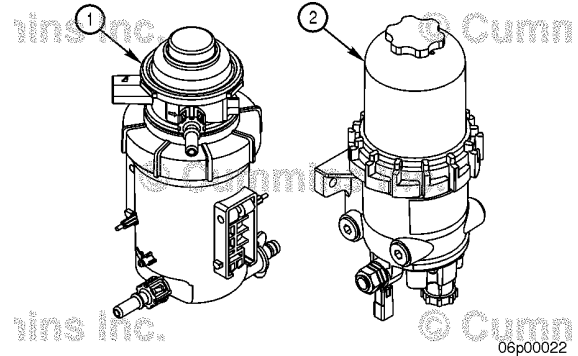

Preparatory Steps

⚠ WARNING

Depending on the circumstance, diesel fuel is flammable. When inspecting or performing service or repairs on the fuel system, to reduce the possibility of fire and resulting severe personal injury, death or property damage, never smoke or allow sparks or flames (such as pilot lights, electrical switches, or welding equipment) in the work area.

⚠ WARNING

Do not bleed the fuel system of a hot engine; this can result in fuel spilling onto a hot exhaust manifold, which can cause a fire.

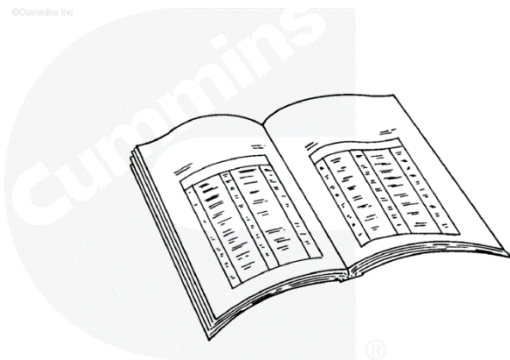

ck800wa

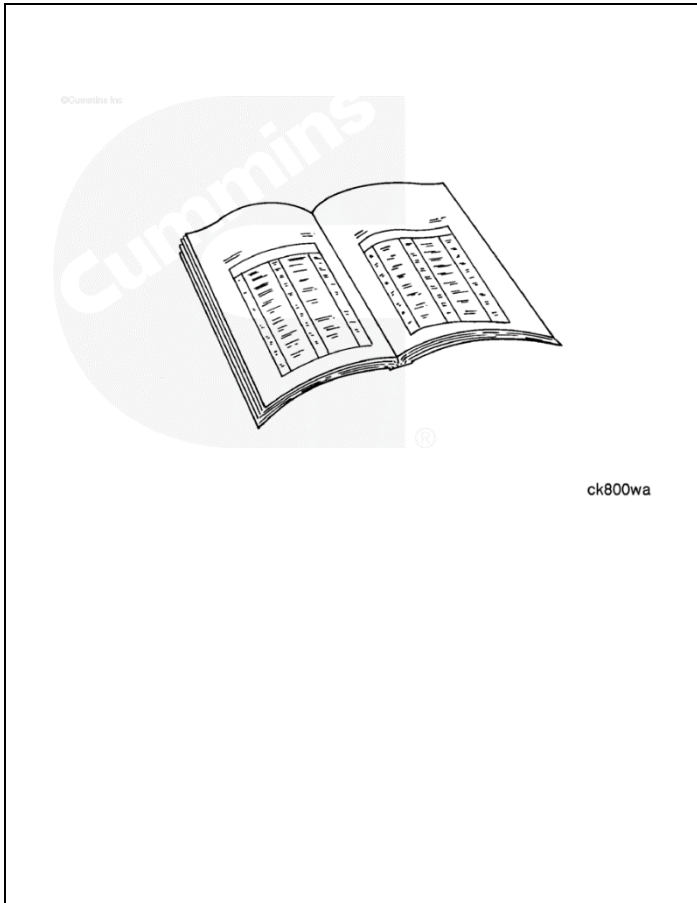

⚠ WARNING

Batteries can emit explosive gases. To reduce the possibility of personal injury, always ventilate the compartment before servicing the batteries. To reduce the possibility of arcing, remove the negative (-) battery cable first and attach the negative (-) battery cable last.

⚠ WARNING

Wear appropriate eye and face protection when using compressed air. Flying debris and dirt can cause personal injury.

⚠ WARNING

When using a steam cleaner, wear safety glasses or a face shield, as well as protective clothing. Hot steam can cause serious personal injury.

- Disconnect the batteries. See equipment manufacturer service information.
- Clean the area around the fuel filter.
- If required, disconnect the wiring harness from the fuel heater.
- Disconnect the fuel lines.

Clean all around the filter area before disassembly. Dirt or contaminants can damage the fuel system.

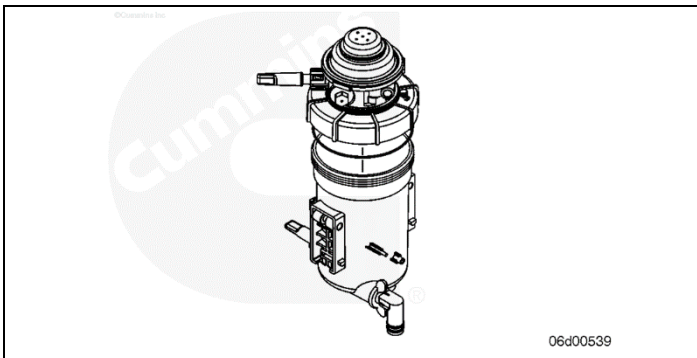

Remove

Loosen the top of the fuel filter housing and remove the sealing o-ring, as well as the fuel filter element.

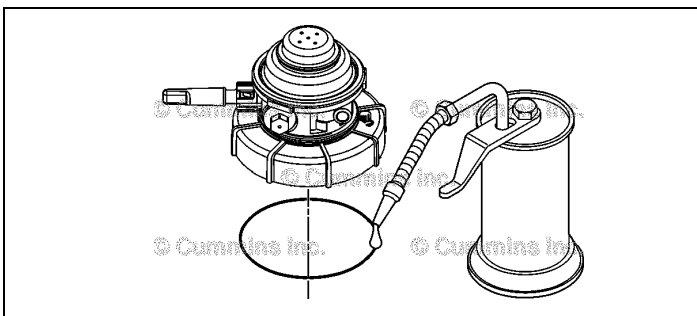

Install

⚠ CAUTION

Do not pre-fill the pressure side fuel filter with fuel. The system must be primed after the fuel filter is installed. Pre-filling the pressure side fuel filter can result in debris entering the fuel system and damaging fuel system components.

Use the correct fuel filter. Lubricate the fuel filter o-ring seal with clean lubricating oil.

CAUTION

Mechanical overtightening can distort the threads as well as damage the filter element seal or filter can.

Install the fuel filter element in the fuel filter housing. The stand pipe base and fuel filter element have an oval interface; make sure the fuel filter element is properly aligned.

Install the top of the fuel filter housing and hand tighten.

Do **not** pre-fill the cartridge style fuel filter/housing.

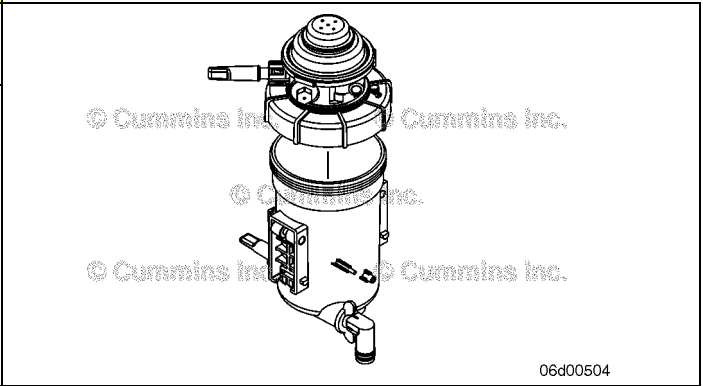

Finishing Steps

WARNING

Batteries can emit explosive gases. To reduce the possibility of personal injury, always ventilate the compartment before servicing the batteries. To reduce the possibility of arcing, remove the negative (-) battery cable first and attach the negative (-) battery cable last.

- Connect the fuel lines.
- If required, connect the wiring harness to the fuel heater.
- Connect the batteries. See equipment manufacturer service information.
- Operate the engine and check for leaks.

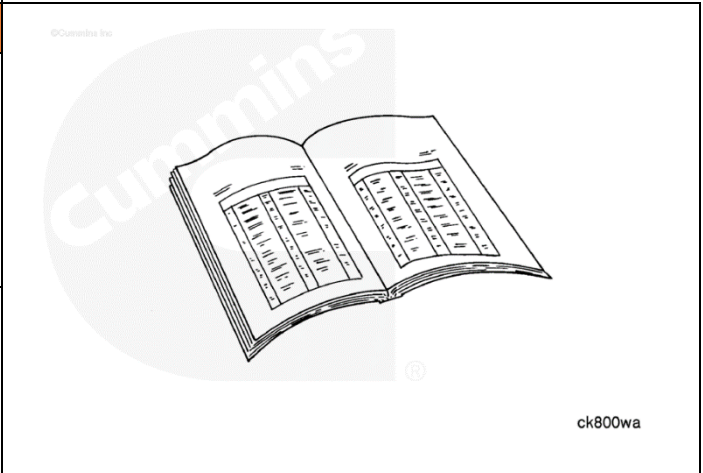

Prime

WARNING

The fuel pump high-pressure fuel lines and fuel rail contain very high-pressure fuel. Never loosen any fittings while the engine is running. Personal injury and property damage can result.

WARNING

Do not engage the starter motor for more than 30 seconds at a time. Allow two minutes between cranking intervals.

After a filter change or running the vehicle tank dry:
 Make sure there is fuel in the vehicle fuel tank.
NOTE: It is **not** necessary to vent air from the high pressure fuel system before starting the engine. Cranking the engine will prime the fuel system.

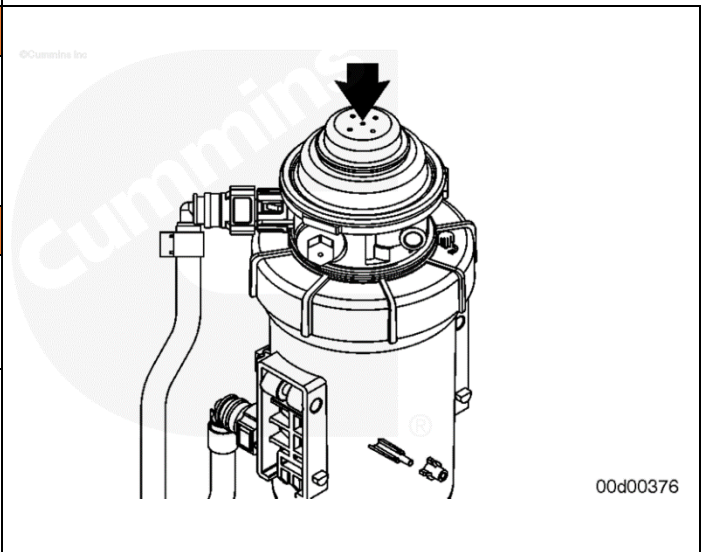

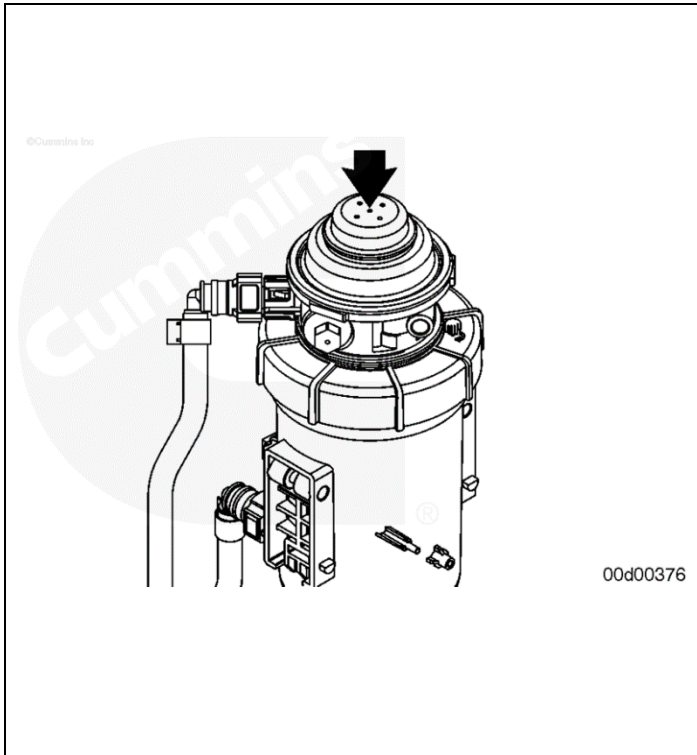

Pump the primer handle until resistance is felt and the handle can not be pumped anymore (approximately 140 to 150 strokes for dry filters).

Crank the engine. If the engine does **not** start after 30 seconds, turn the keyswitch to the OFF position.

Pump the priming pump again, repeating the previous steps until the engine starts.

When the engine does start, it may run erratically and with increased noise levels for a few minutes. This is a normal condition.

NOTE: It is possible that Fault Code 559 may become active after fuel filter replacement due to air introduced into the system. Be sure to operate the engine until air is purged and use INSITE™ electronic service tool to clear the fault code before releasing the vehicle.

Operate the engine and check for leaks.

Lubricating Oil and Filters Drain

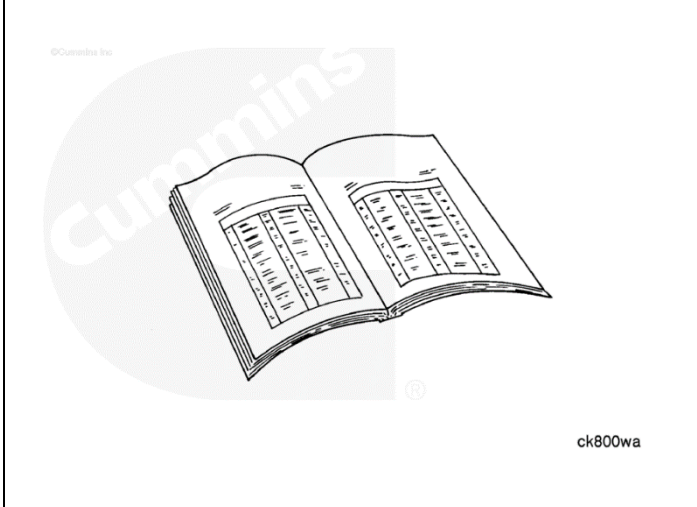

⚠️ WARNING

Some state and federal agencies have determined that used engine oil can be carcinogenic and cause reproductive toxicity. Avoid inhalation of vapors, ingestion, and prolonged contact with used engine oil. If not reused, dispose of in accordance with local environmental regulations.

⚠️ WARNING

To reduce the possibility of personal injury, avoid direct contact of hot oil with your skin.

Change the lubricating oil and filter(s) at the specified oil change interval. See the Maintenance Schedule to find the correct change interval for your application.

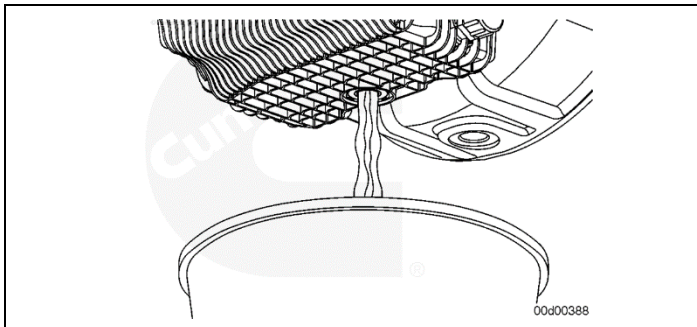

NOTE: Use a container that can hold at least 10 liters [10.6 qt] of engine lubricating oil.

Operate the engine until the water temperature reaches 60°C [140°F].

Shut off the engine.

Remove the oil drain plug. Drain the oil immediately to be sure all the oil and suspended contaminants are removed from the engine.

Remove
 Clean the area around the lubricating oil filter head.

Use a Cummins® oil filter wrench, Part Number 3400158, or a 1/2" drive (bottom of the oil filter), to remove the filter.

Clean the gasket surface of the filter head.

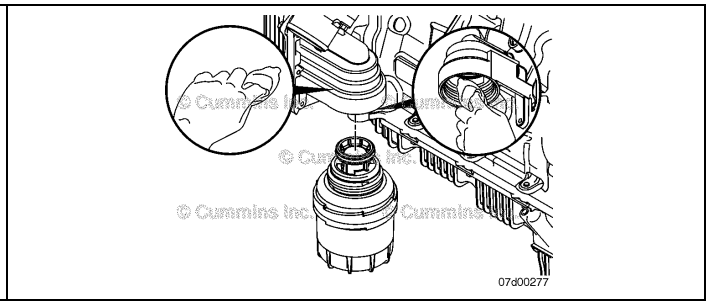

Install
 Use the correct oil filter.

Reference the Cummins®/Fleetguard®/Nelson® filter specifications for the correct oil filter part number.

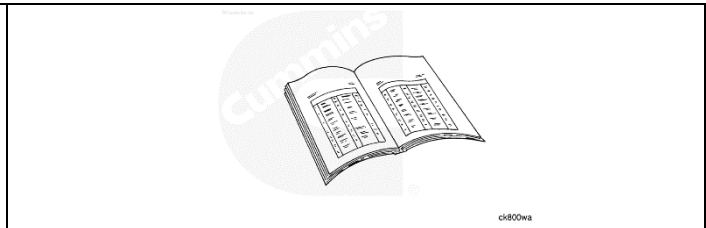

CAUTION

The lack of lubrication during the delay until the filter is pumped full of oil at start-up can damage the engine.

Use the correct grade and specification of engine oil. Refer to Lubricating Oil Recommendations and Specifications.

Use clean oil to coat the gasket surface of the filter.

Fill the filter with clean oil.

NOTE: Be careful that no debris is poured into the filter. If using an oil supply with a metallic or plastic seal under the cap, be careful to peel the seal back. Puncturing the seal with a knife or sharp object can result in debris falling into the oil container.

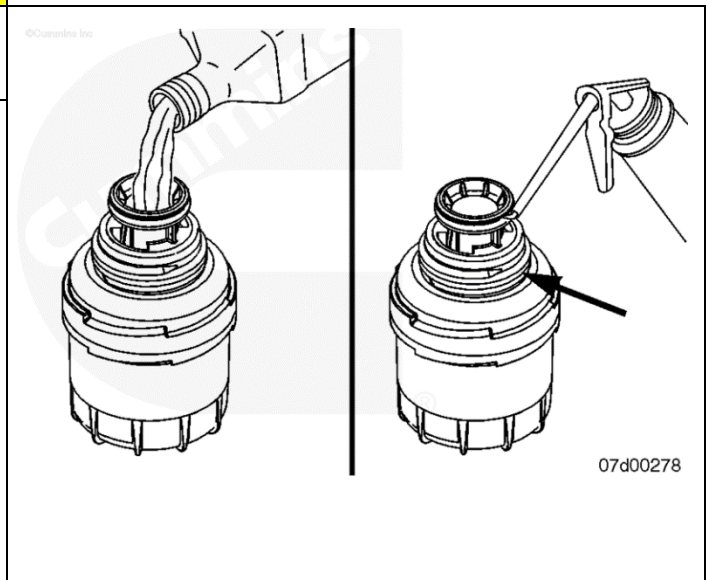

CAUTION

Mechanical overtightening of filter can distort the threads or damage the filter element seal.

Install the filter on the oil filter head. Tighten the filter until the gasket contacts the filter head surface.

Tighten the filter 1/2 turn after the filter makes contact with the filter head, or tighten to the following value.

Torque Value: 38 N•m [28 ft-lb]

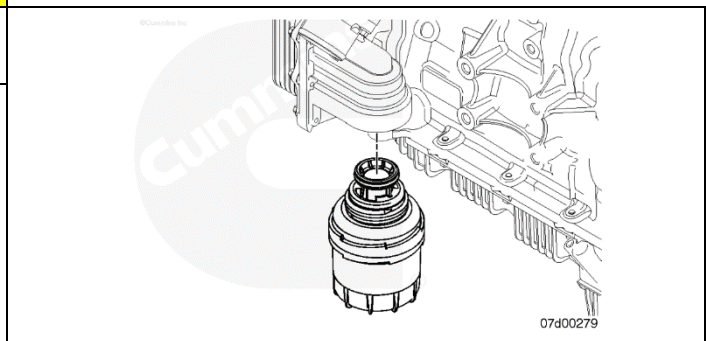

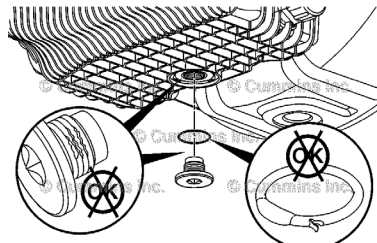
 <p>07d00321</p>	<p>Fill</p> <p>Clean and check the lubricating oil drain plug threads and sealing surface. Use a new sealing o-ring, if damaged.</p> <p>Install the lubricating oil pan drain plug.</p> <p>Torque Value: Plastic Oil Drain Plug 24 N•m [212 in-lb]</p>
---	--

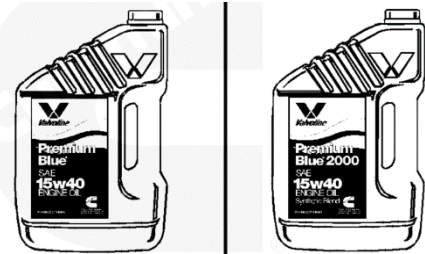
 <p>pl800gb</p>	<p>NOTE: Use a high-quality 15W-40 multiviscosity lubricating oil, such as Valvoline Premium Blue™, or its equivalent in Cummins® engines. Choose the correct lubricating oil for your operating climate.</p>
--	--

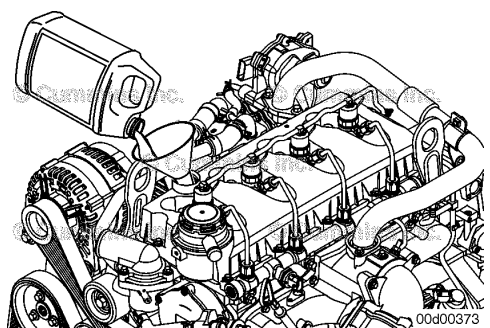
 <p>00d00373</p>	<p>Fill the engine with clean lubricating oil to the proper level.</p>
--	--

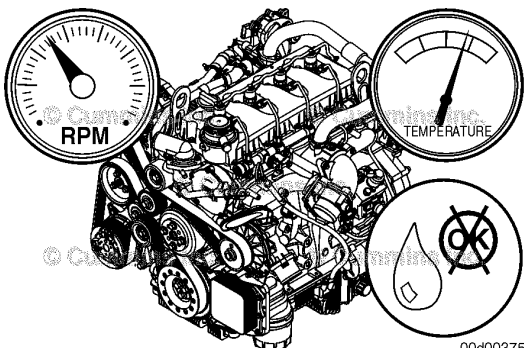
 <p>00d00375</p>	<p>Idle the engine to inspect for leaks at the drain plug and, if changed, the oil filter seal.</p> <p>NOTE: Engine oil pressure must be indicated on the gauge within 15 seconds after starting. If oil pressure is not registered within 15 seconds, shut off the engine immediately to avoid engine damage. Confirm the correct oil level is in the oil pan.</p>
---	--

Shut off the engine. Wait approximately 5 minutes to let the oil drain from the upper parts of the engine. Check the level again.

Add oil as necessary to bring the oil level to the H (high) mark on the dipstick.

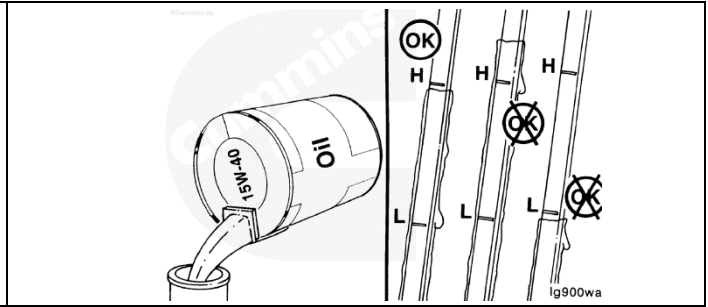

Radiator Pressure Cap
General Information

The cooling system is designed to use a pressure cap to prevent boiling of the coolant.

Use the following procedure for the minimum pressure rating. This is an absolute minimum value. See equipment manufacturer service information for the correct radiator pressure cap.

An incorrect or malfunctioning cap can result in the loss of coolant and the engine running hot.

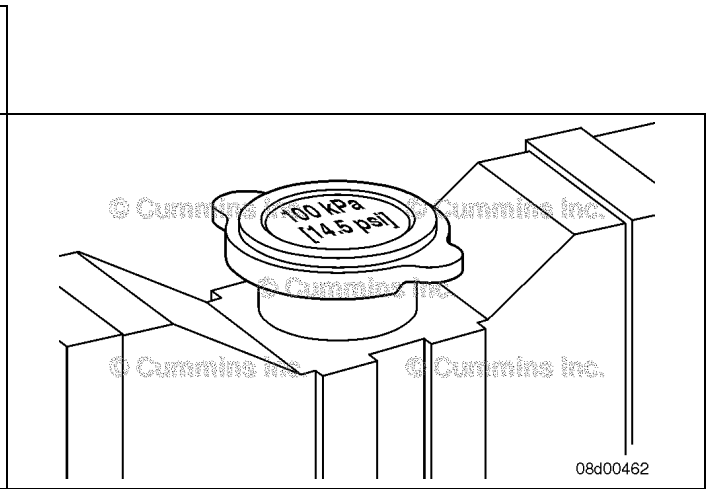

Inspect for Reuse

Be sure the correct radiator pressure cap is being used. Inspect the rubber seal of the pressure cap for damage. Inspect the radiator fill neck for cracks or other damage. See equipment manufacturer service information for instructions if the fill neck is damaged.

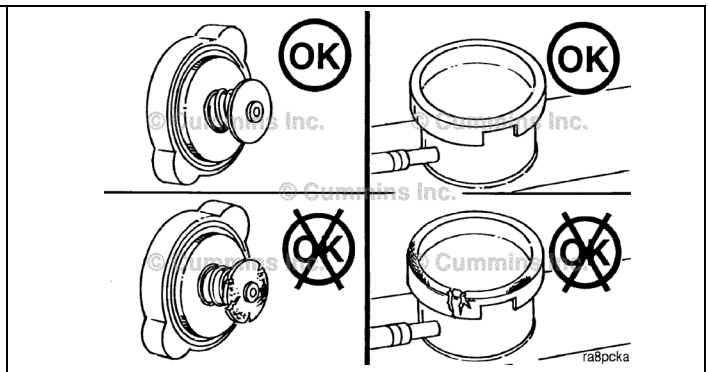

Pressure-test the radiator cap. See equipment manufacturer service information for radiator cap test procedures.

The pressure cap **must** seal within 14 kPa [2 psi] of the value stated on the cap, or it **must** be replaced.

An incorrect or malfunctioning cap can result in the loss of coolant and the engine running hot.

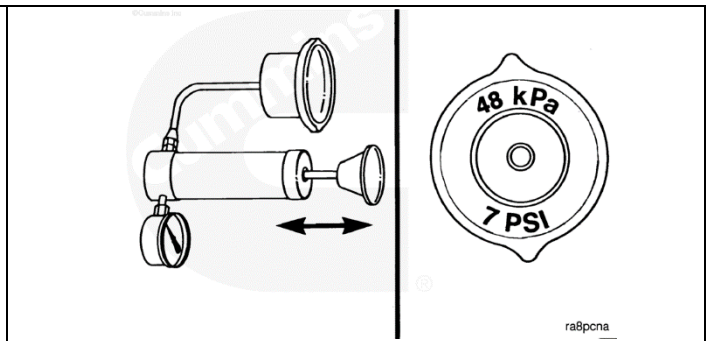

Engine Coolant Antifreeze Maintenance Check

CAUTION

Overconcentration of antifreeze or use of high silicate antifreeze can cause damage to the engine.

Check the antifreeze concentration. Use a mixture of 50-percent water and 50-percent ethylene glycol or propylene glycol-base antifreeze to protect the engine to -32°C [-25°F] year-around.

The Fleetguard® refractometer, Part Number CC-2806 or CC-2800, provides a reliable, easy to read, and accurate measurement of freezing point protection and glycol (antifreeze) concentration.

To check the antifreeze concentration:

- 1 Place a drop of coolant on the refractometer window and shut the lid.
- 2 Look through the eyepiece and focus.
- 3 Record the freeze point protection for either ethylene glycol or propylene glycol coolants.

NOTE: Antifreeze is essential in every climate. It broadens the operating temperature by lowering the coolant freezing point and by raising its boiling point.

The corrosion inhibitors also protect the cooling system components from corrosion and provides longer component life.

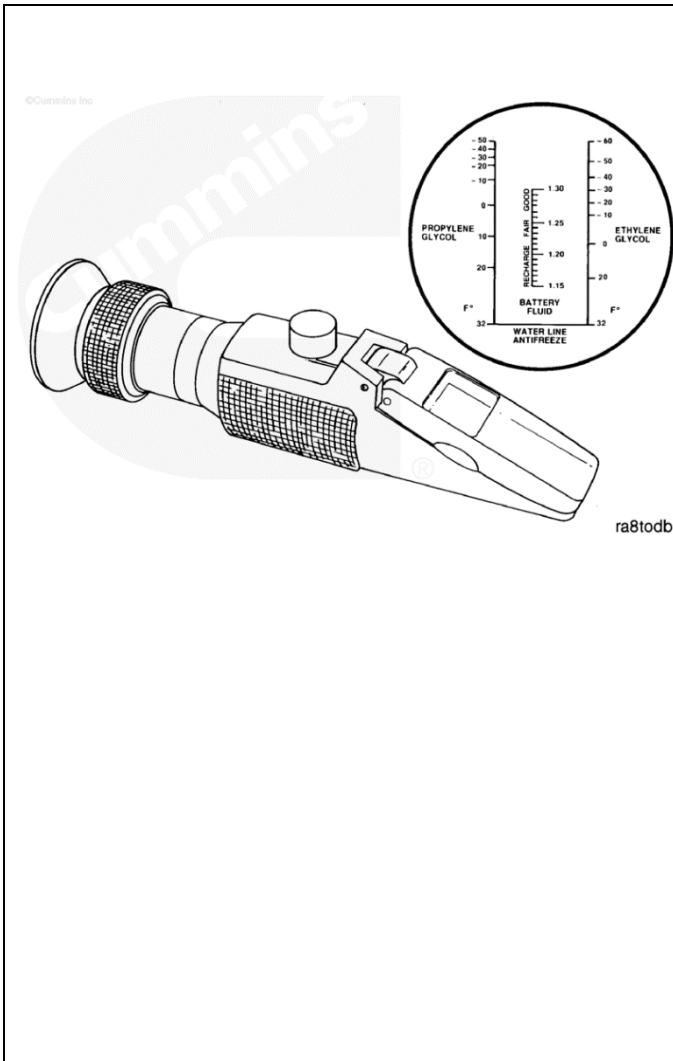

Batteries Initial Check

If conventional batteries are used, remove the cell caps or covers and check the electrolyte level.

NOTE: Maintenance-free batteries are sealed and do **not** require the addition of water.

Fill each battery cell with distilled water. Refer to the battery manufacturer's specifications.

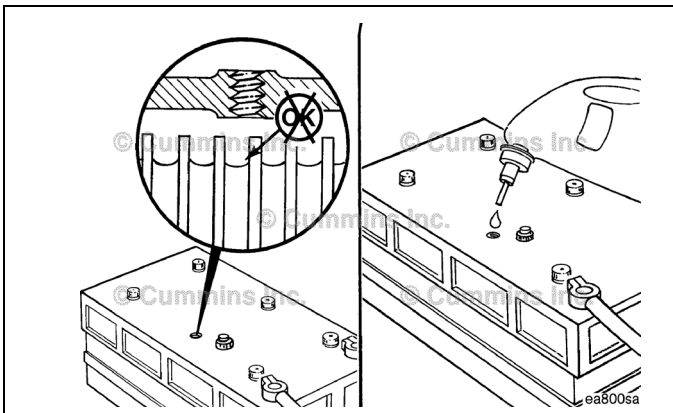

Use the Fleetguard® refractometer, Part Number CC-2800, to check the specific gravity of the battery electrolyte.

Refer to the battery fluid column in the refractometer to determine the state of charge of each battery cell.

If water has been added to a dry cell, recharge the battery to mix the added water with the existing battery electrolyte, to prevent incorrect readings.

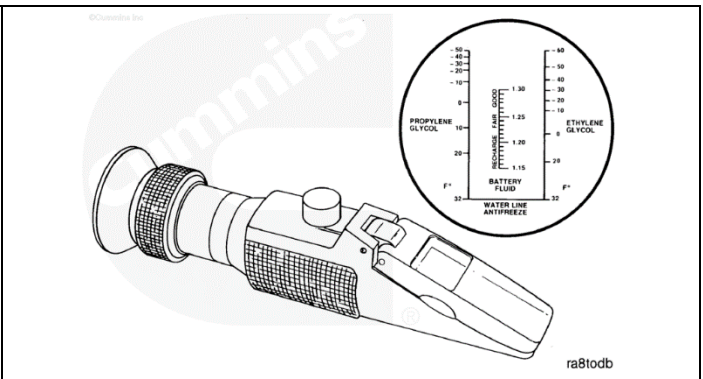

CAUTION

Do not connect battery charging cables to any electronic control system part. This can damage the electronic control system parts.

Use a carbon-pile load (battery/alternator tester) to test the output amperage of maintenance-free or conventional vent cap batteries.

If the output amperage is low, use a battery charger to charge the battery. See equipment manufacturer service information.

Replace the battery if it will not charge to the original equipment manufacturer (OEM) specifications or will not maintain a charge.

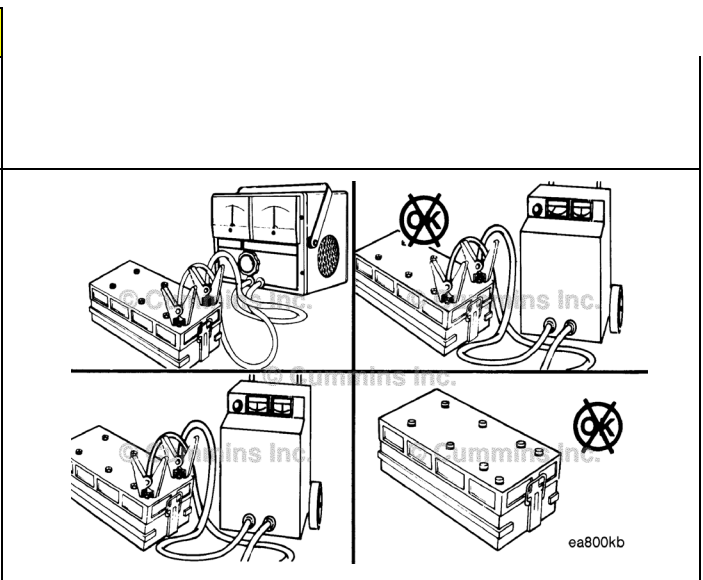

**Battery Cables and Connections
Initial Check**

There are two possible heavy-duty battery connections:

- Battery terminal and clamp (1)
- Threaded battery terminal and nut (2).

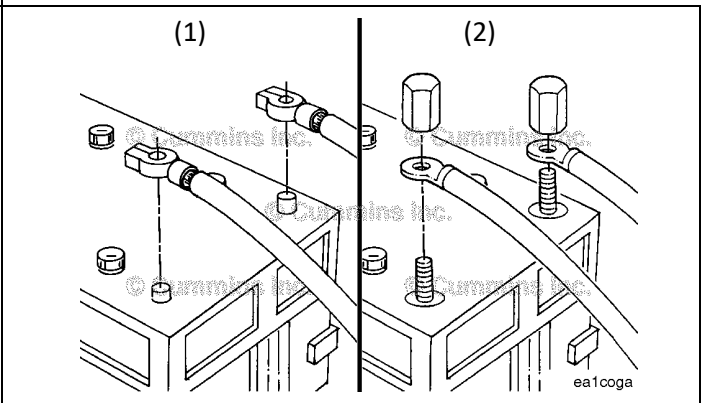

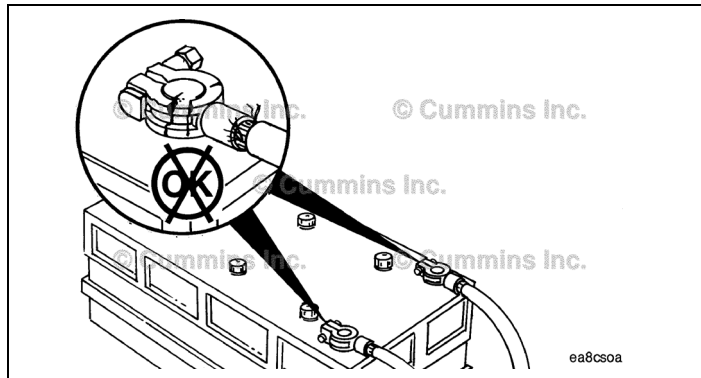

WARNING

Batteries can emit explosive gases. To reduce the possibility of personal injury, always ventilate the compartment before servicing the batteries. To reduce the possibility of arcing, remove the negative (-) battery cable first and attach the negative (-) battery cable last.

Remove and inspect the battery cables and connections for cracks or corrosion.

Replace broken terminals, connectors, or cables.

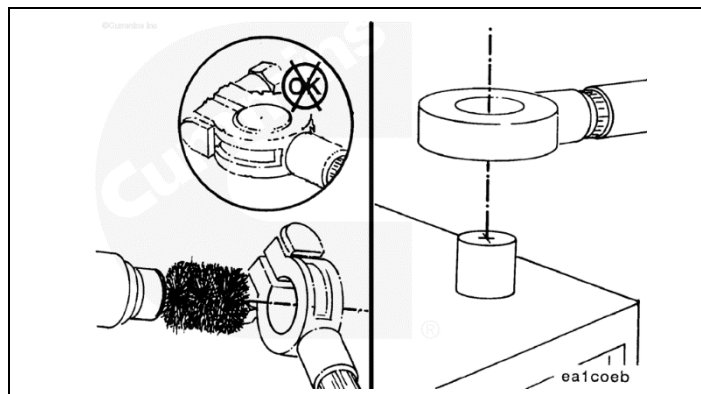

If the connections are corroded, use a battery brush or wire brush to clean the connections until shiny.

Make sure all debris is removed from the connecting surfaces.

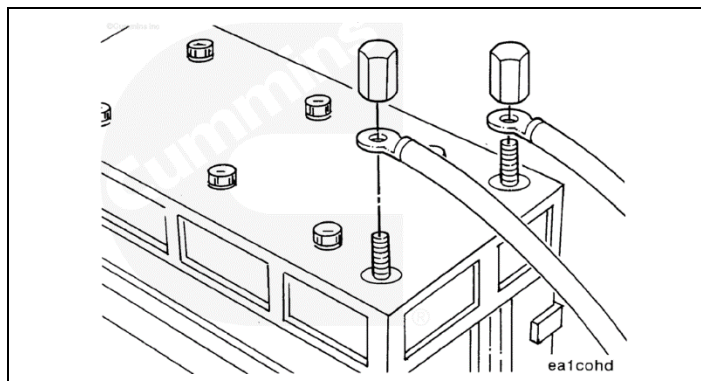

WARNING

Batteries can emit explosive gases. To reduce the possibility of personal injury, always ventilate the compartment before servicing the batteries. To reduce the possibility of arcing, remove the negative (-) battery cable first and attach the negative (-) battery cable last.

Install the cables and tighten the battery connections. Coat the terminals with grease to prevent corrosion.

Maintenance Procedures at 1000 Hours or 1 Year

Maintenance Procedures - Overview

General Information

All maintenance checks and inspections listed in previous maintenance intervals **must** also be performed at this time, in addition to those listed under this maintenance interval.

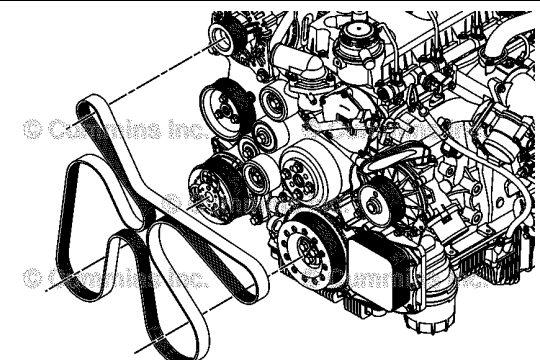
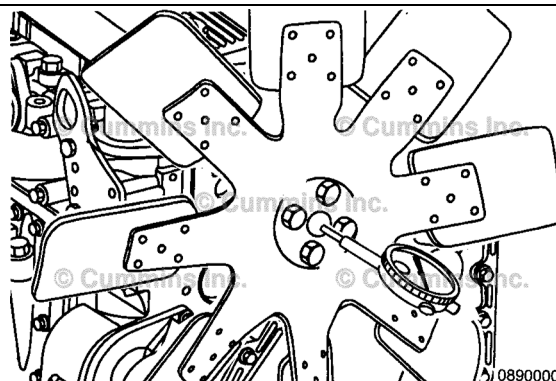
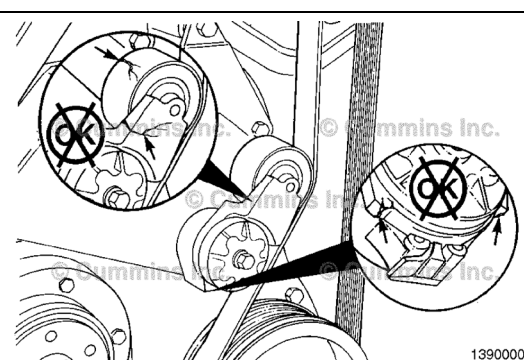
<p>Fan Hub, Belt Driven Maintenance Check</p> <p>Remove the belt. Refer to engine owner's manual.</p>	 <p>00d00392</p>
<p>Check the fan hub bearing. The fan hub must rotate without any wobble or excessive end clearance.</p>	 <p>08900009</p>
<p>Cooling Fan Belt Tensioner Initial Check</p> <p>With the engine stopped, check the tensioner arm, pulley, and stops for cracks. If any cracks are found, the tensioner must be replaced.</p>	 <p>13900004</p>

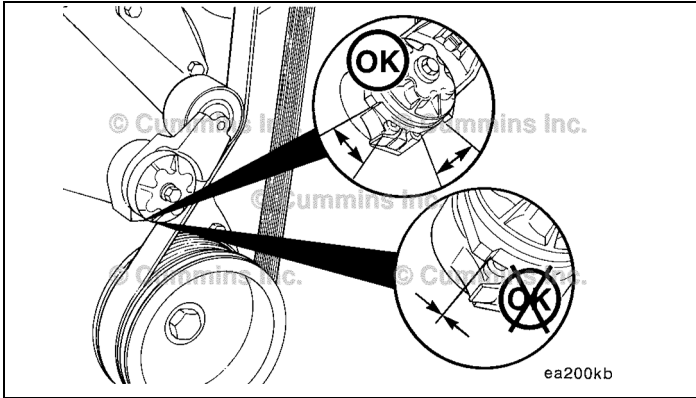

With the belt installed, verify that neither tensioner arm stop is in contact with the spring casing stop. If either of the stops is touching:

- Verify the correct belt part number is installed.
- If the correct belt is installed, replace the belt.

After replacing the belt, if the tensioner arm stops are still in contact with the spring case stop, replace the tensioner.

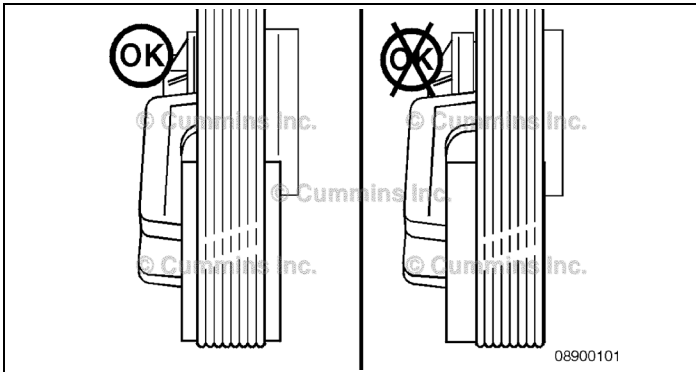

Check the location of the drive belt on the belt tensioner pulley. The belt should be centered on, or close to the middle of, the pulley. Misaligned belts, either too far forward or backward, can cause belt wear, belt roll-off malfunctions, or increase uneven tensioner bushing wear.

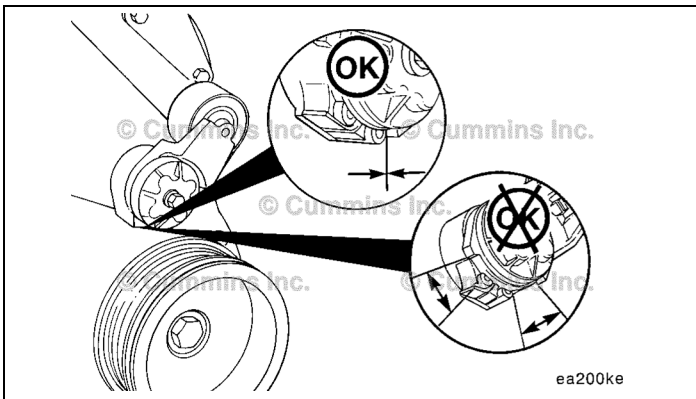

Remove the drive belt.

With the belt removed, verify that the tensioner arm stop is in contact with the spring case stop. If they are not touching, the tensioner must be replaced.

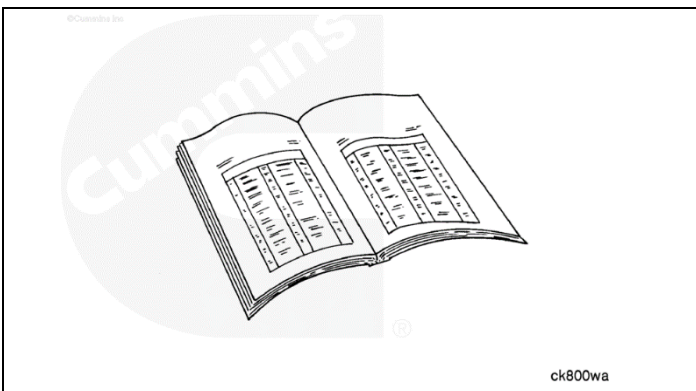

Preparatory Steps

⚠ WARNING

Batteries can emit explosive gases. To reduce the possibility of personal injury, always ventilate the compartment before servicing the batteries. To reduce the possibility of arcing, remove the negative (-) battery cable first and attach the negative (-) battery cable last.

- Disconnect the batteries. See equipment manufacturer service information.
- Remove the drive belt.

Remove
 Remove the capscrew and belt tensioner from the bracket.

NOTE: Most belt tensioners are mounted to a separate mounting bracket and use internal fasteners for clearance.

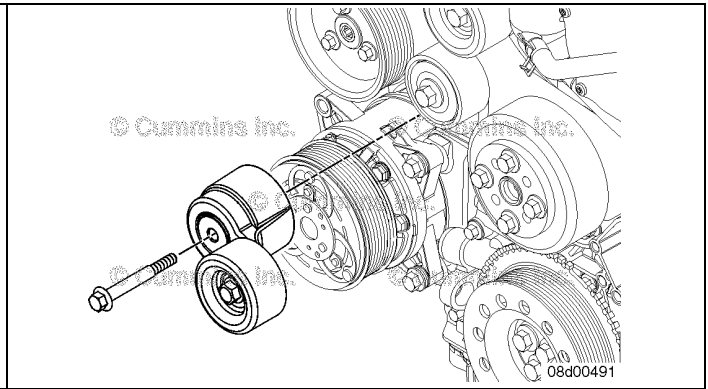

Clean and Inspect for Reuse
 Check the belt for damage.

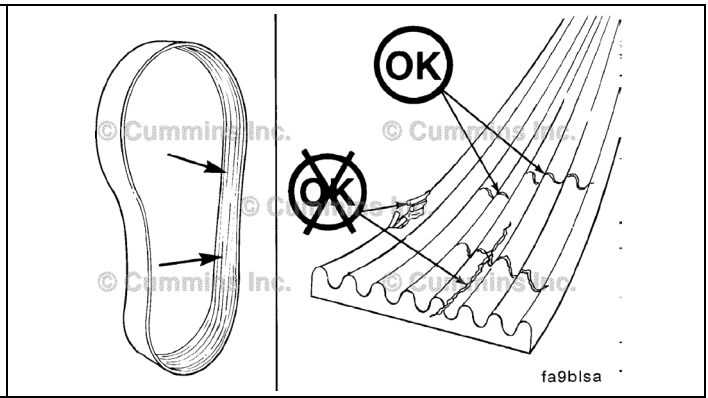

Measure the clearance between the tensioner spring and the tensioner arm to verify tensioner wear-out and uneven bearing wear. If the clearance exceeds 3 mm [0.12 in] at any point, the tensioner has failed and **must** be replaced as a complete assembly.

Tensioners generally show a larger clearance gap near the lower portion of the spring case, resulting in the upper portion rubbing against the tensioner arm. **Always** replace the belt when a tensioner is replaced.

- 1 Tensioner cap
- 2 Tensioner arm
- 3 Spring case
- 4 Pulley
- 5 Clearance gap.

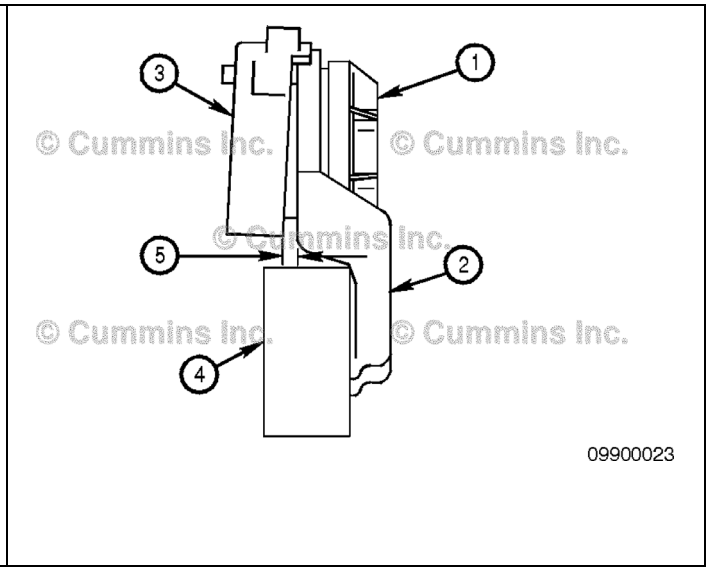

Inspect the tensioner for evidence of the tensioner arm contacting the tensioner cap. If there is evidence of the two areas making contact, the pivot tube bushing has failed and the tensioner **must** be replaced.

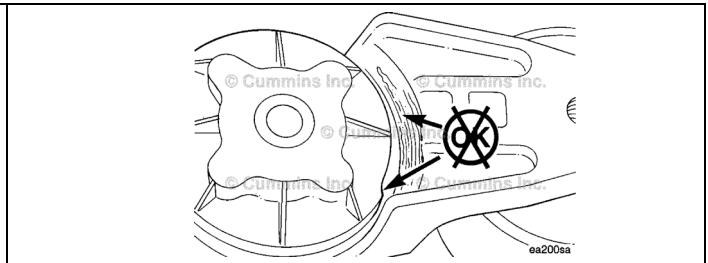

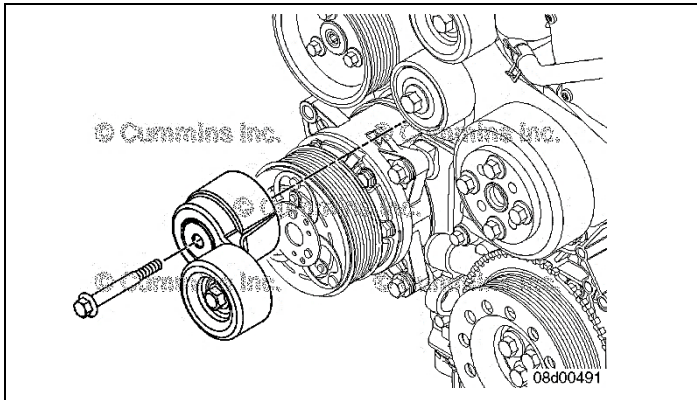

Install

If removed, install the belt tensioner mounting bracket and mounting bracket capscrews.

Install the belt tensioner and capscrew.

Tighten the capscrew.

Torque Value: 43 N•m [32 ft-lb]

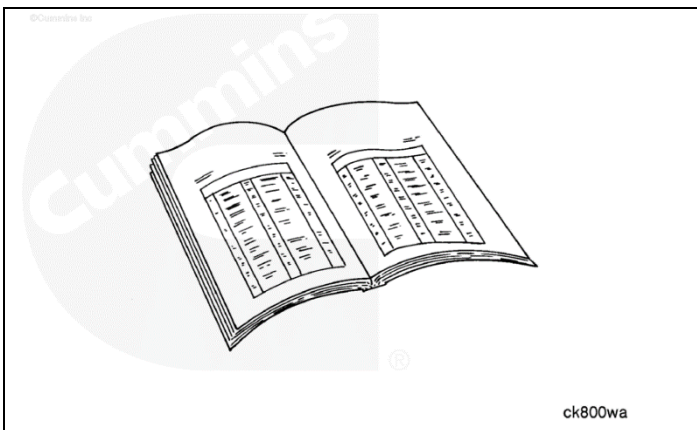

Finishing Steps

⚠ WARNING

Batteries can emit explosive gases. To reduce the possibility of personal injury, always ventilate the compartment before servicing the batteries. To reduce the possibility of arcing, remove the negative (-) battery cable first and attach the negative (-) battery cable last.

- Install the drive belt.
- Connect the batteries. See equipment manufacturer service information.
- Operate the engine and check for proper operation.

Maintenance Procedures at 2000 Hours or 2 Years

Maintenance Procedures - Overview General Information

All maintenance checks and inspections listed in previous maintenance intervals **must** also be performed at this time, in addition to those listed under this maintenance interval.

Overhead Set Adjust

To check and adjust the overhead set requires the removal of high-pressure fuel system components. This service should only be performed by trained, experienced technicians. Contact a Cummins® Authorized Repair Location.

**Cooling System
General Information**

⚠ WARNING

Do not remove the pressure cap from a hot engine. Wait until the coolant temperature is below 50°C [120°F] before removing the pressure cap. Heated coolant spray or steam can cause personal injury.

NOTE: Never use a sealing additive to stop leaks in the coolant system. This can result in coolant system plugging and inadequate coolant flow, causing the engine to overheat.

The engine coolant level must be checked daily.

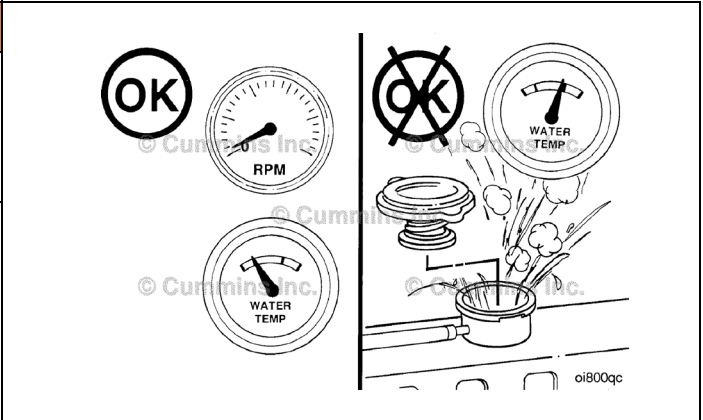

⚠ CAUTION

Do not add cold coolant to a hot engine. Engine castings can be damaged. Allow the engine to cool below 50°C [122°F] before adding coolant.

NOTE: In the event of a water pump or exhaust gas recirculation (EGR) cooler malfunction, check the coolant level switch or sensor for proper operation. See equipment manufacturer service information for operational checks and repairs.

On applications that use a coolant recovery system, check to make sure the coolant is at the appropriate level on the coolant recovery tank, for the engine temperature.

Many coolant recovery/expansion tanks, also called "top tanks", have sight glasses (1) or are made of a clear material (not shown) to aid in checking the coolant level (2) without removing the radiator cap.

It is important to understand the impact of temperature on the expansion of the coolant. Most "top tanks" do not have a provision for a "FULL HOT" coolant level. Filling the "top tank" while hot will result in a low operating level once the system has cooled.

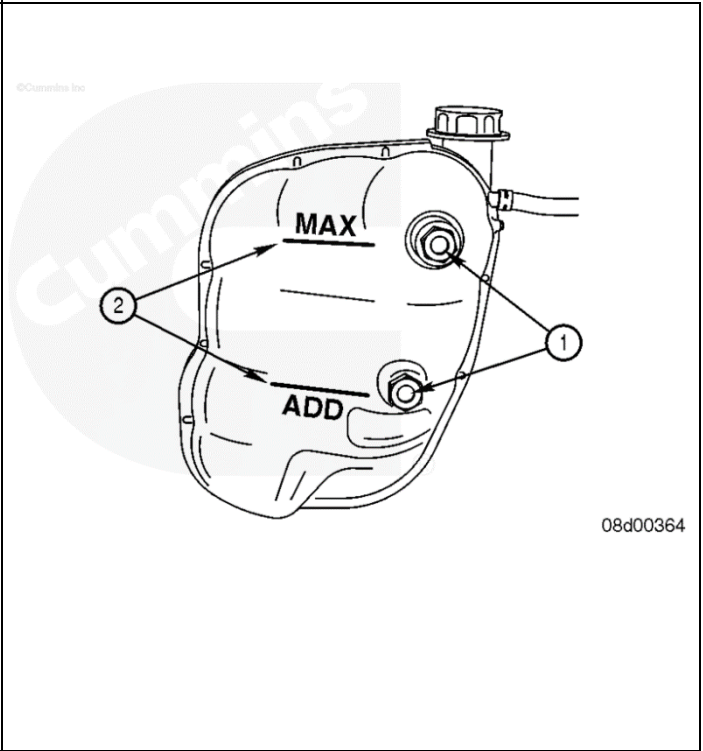

Fill the cooling system with coolant to the bottom of the fill neck in the radiator fill or recovery/expansion tank.

NOTE: Some radiators have two fill necks, both of which **must** be filled when the cooling system is filled.

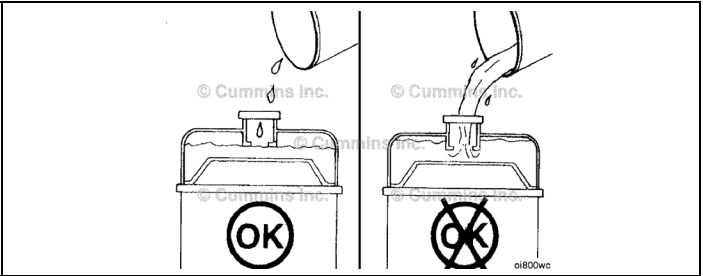

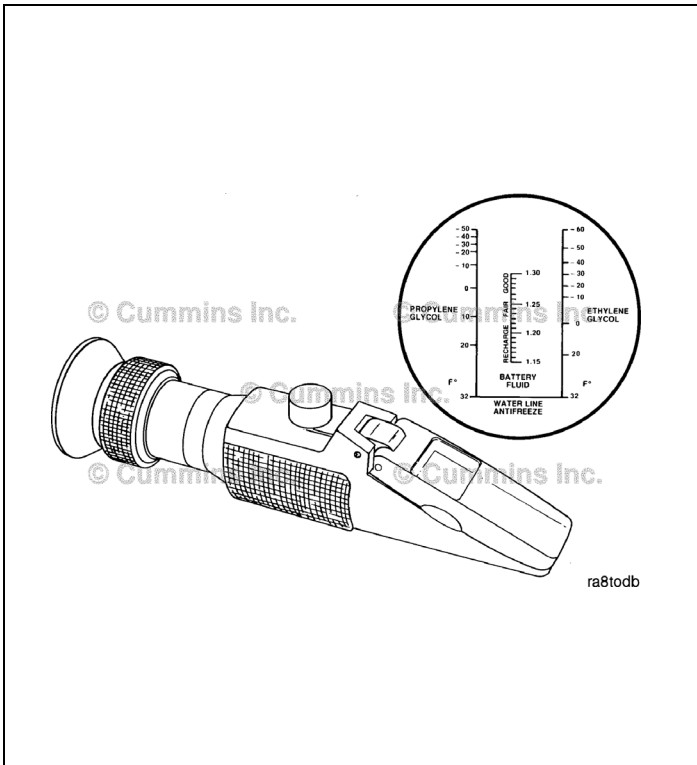

Maintenance Check

CAUTION

Over-concentration of antifreeze or use of high silicate antifreeze can cause damage to the engine.

Check the antifreeze concentration. Use a mixture of 50-percent water and 50-percent ethylene glycol or propylene glycol-base antifreeze to protect the engine to -32°C [-25°F] year-around.

The Fleetguard™ refractometer, Part Number CC-2806, provides a reliable, easy to read, and accurate measurement of freeze point protection and glycol (antifreeze) concentration.

Antifreeze is essential in every climate as it broadens the operating temperature by lowering the coolant freeze point and by raising its boiling point.

The corrosion inhibitors also protect the cooling system components from corrosion and provides longer component life.

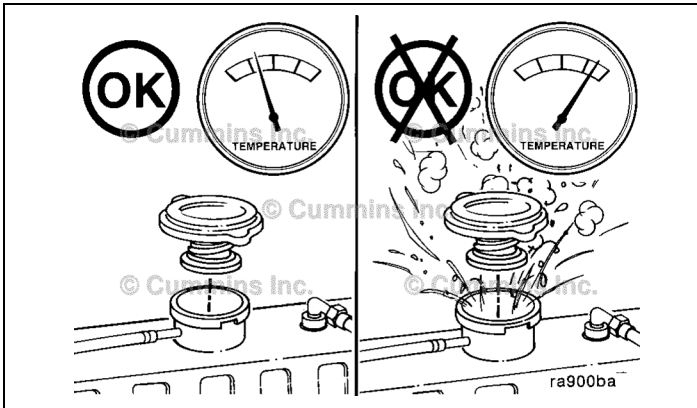

Drain

WARNING

Do not remove the pressure cap from a hot engine. Wait until the coolant temperature is below 50°C [122°F] before removing the pressure cap. Heated coolant spray or steam can cause personal injury.

Remove the radiator/expansion tank cap.

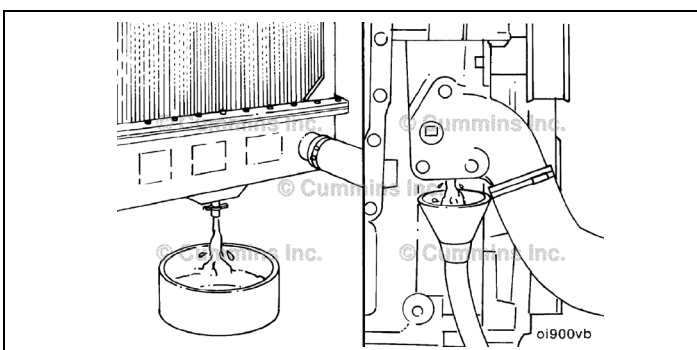

WARNING

Coolant is toxic. Keep away from children and pets. If not reused, dispose of in accordance with local environmental regulations.

Drain the cooling system by opening the drain valve on the radiator and removing the plug in the bottom of the water inlet. A drain pan with a capacity of 19 liters [5 gal] will be adequate in most applications.

NOTE: On applications with exhaust gas recirculation (EGR) system, disconnect the EGR cooler coolant return line to make sure the coolant is drained from the EGR cooler. Contact a Cummins® Authorized Repair Location.

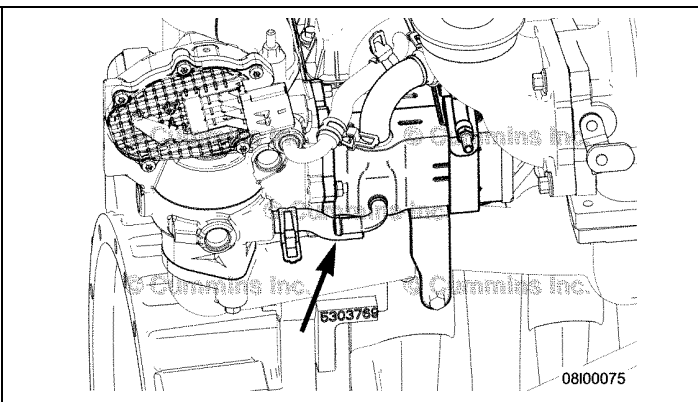

Check for damaged hoses and loose or damaged hose clamps. Replace as required. Check the radiator for leaks, damage, and buildup of dirt. Clean and replace as required.

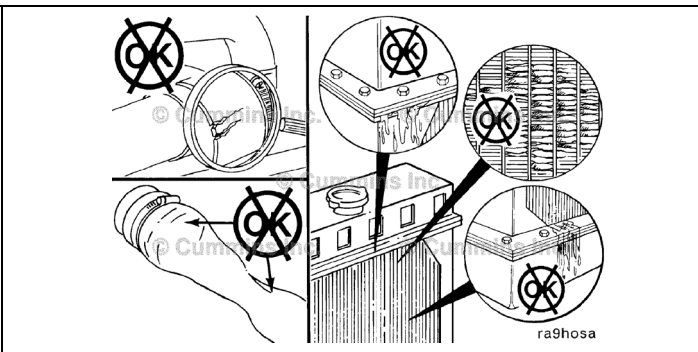



Flush

CAUTION

The cooling system must be filled properly to prevent air locks. During filling, air must be vented from the engine coolant passages. Wait 2 to 3 minutes to allow air to be vented; then add mixture to bring the level to the top.

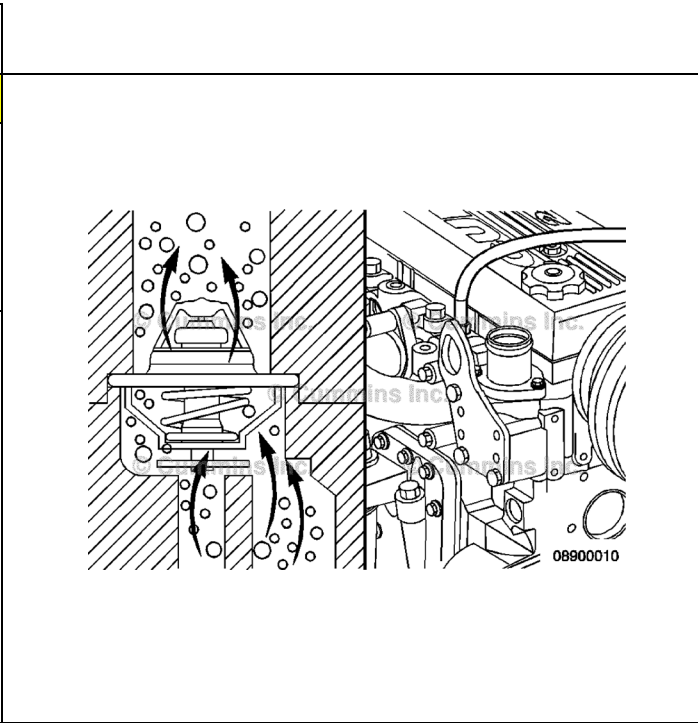
- To make sure air is vented during the fill process:
- The thermostat has check balls that allow air to vent through the thermostat when the thermostat is closed.
 - A deaeration port is located next to the water outlet connection, which connects to the top tank/coolant recovery tank of the cooling system.
- This provides adequate venting for a fill rate of 19 liters [5 gal] per minute.

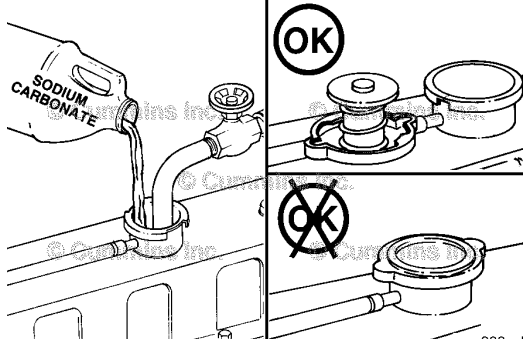

 <p>ra8togc</p>	<p>NOTE: An alternate to using sodium carbonate, as outlined in this procedure, is to use Restore™.</p> <p>Restore™ is a heavy-duty cooling system cleaner that removes corrosion products, silica gel, and other deposits. The performance of Restore™ is dependent on time, temperature, and concentration levels. An extremely scaled or flow-restricted system, for example, can require higher concentrations of cleaner, higher temperatures, longer cleaning times, or the use of Restore Plus™. Up to twice the recommended concentration levels of Restore™ can be used safely. Restore Plus™ must be used only at its recommended concentration level. Extremely scaled or fouled systems can require more than one cleaning.</p>
--	--

 <p>ra900wd</p>	<p style="text-align: center;">CAUTION</p> <p>Do not install the radiator cap. The engine is to be operated without the cap for this process.</p> <ol style="list-style-type: none"> 1 Close the radiator drain valve. 2 Install the plug in the water inlet connection. 3 Install the EGR coolant return connection. <p>Fill the cooling system with a mixture of sodium carbonate and water (or a commercially available equivalent). NOTE: Adequate venting is provided for a fill rate of 11 liters [3 gal] per minute.</p>
---	---

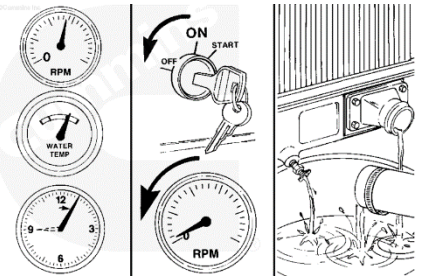
 <p>oi800w10</p>	<p style="text-align: center;">WARNING</p> <p>Coolant is toxic. Keep away from children and pets. Dispose of in accordance with local environmental regulations.</p> <p>Operate the engine for 5 minutes with the coolant temperature above 80°C [176°F].</p> <p>Shut the engine OFF, allow to cool to 50° C [120°F], and drain the cooling system.</p>
---	---

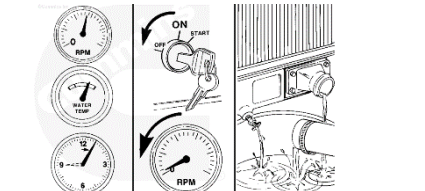
 <p>oi800w10</p>	<p>Operate the engine for 5 minutes with the coolant temperature above 80°C [176°F].</p> <p>Shut the engine OFF, allow to cool to 50° C [120°F], and drain</p> <p>NOTE: If the water being drained is still dirty, the system must be flushed again until the water is clean.</p>
---	--

⚠ CAUTION
<p>Fill</p> <p>The cooling system must be filled properly to prevent air locks. During filling, air must be vented from the engine coolant passages. Wait 2 to 3 minutes to allow air to be vented; then add mixture to bring the level to the top.</p>
⚠ CAUTION
<p>Before "topping off" the cooling system allow the system temperature to cool to ambient. This will allow an adequate amount of coolant to be available to the water pump during all periods of operation.</p>
⚠ CAUTION
<p>Engine and component damage may result if adequate cool-down time is not given after the cooling system pressure has been relieved in order to "top off" with coolant. System pressure is only generated with the temperature rise of the coolant. Closing the cooling system while hot will not allow for pressure to build.</p>
<p>To make sure air is vented during the fill process:</p> <ul style="list-style-type: none"> • The thermostat has check balls that allow air to vent through the thermostat when the thermostat is closed. • A deaeration port is located next to the water outlet connection, which connects to the top tank/coolant recovery tank of the cooling system. <p>The system has a design fill rate of 11 liters [3 gal] per minute.</p>

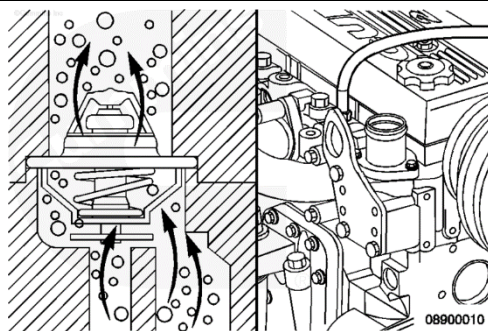

⚠ CAUTION
<p>Do not use water alone for coolant. Damage from corrosion can severely damage the engine cooling system.</p>
<p>Use a mixture of 50-percent water and 50-percent ethylene glycol or propylene glycol antifreeze to fill the cooling system.</p>
<p>Reference the Cummins® Coolant Requirements and Maintenance, Bulletin 3666132, for engine coolant specifications.</p>

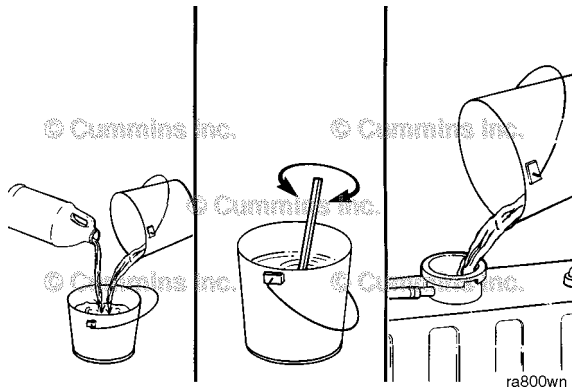

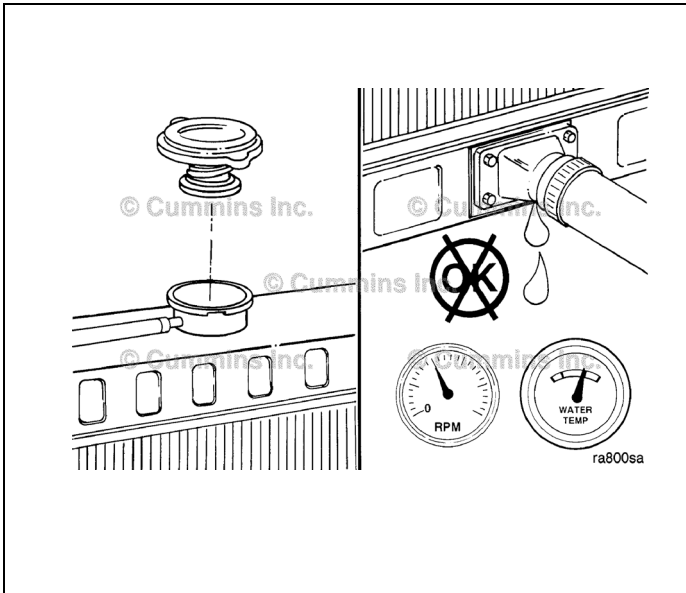

⚠ WARNING

Do not stand near surge tank or radiator while operating the engine with the pressure cap off. If the vehicle is equipped with a fill door on the side of the surge tank, keep it closed due to coolant expansion.

⚠ WARNING

Do not remove the pressure cap from a hot engine. Wait until the coolant temperature is below 50°C [122°F] before removing the pressure cap. Heated coolant spray or steam can cause personal injury.

Install the pressure cap. Operate the engine until it reaches a temperature of 80°C [176°F] and check for coolant leaks.

Check the coolant level again to make certain the system is full of coolant or that the coolant level has risen to the hot level in the recovery/expansion tank in the system, if so equipped.

Additional Engine Service Literature

General Information

Bulletin Number	Title of Publication
4358561	QSF2.8 CM2880 F105 Service Manual
4358563	QSF2.8 CM2880 F105 Fault Code Troubleshooting Manual
4358562	QSF2.8 CM2880 F105 Wiring Diagram
4358560	QSF2.8 CM2880 F105 Operation and Maintenance Manual
4358559	QSF2.8 CM2880 F105 Owner's Manual
3379000	Air for Your Engine
33799001	Fuel for Cummins® Engines
3379009	Operation of Diesel Engines in Cold Climates
3666132	Cummins® Coolant Requirements and Maintenance
3810340	Cummins® Engine Oil and Oil Analysis Recommendations

Service Literature Ordering Location

Contact Information

Service literature can be obtained from the appropriate location listed below:

- Any Cummins® Distributor
- Iron Mountain Fulfillment Services
 - Help Desk (U.S.): 1-800-646-5609
 - Help Desk (Outside U.S.): 1-630-283-2420
 - Email: CECOteam@ironmountain.com
- QuickServ® Online Store
 - <https://store.cummins.com/store>

Service Assistance

General Information

To contact the nearest Cummins® Authorized Repair Location, utilize the Service Locator at www.cummins.com. Cummins Inc. provides a 24-hour, toll free telephone number to aid in technical and emergency service when a Cummins® Authorized Repair Location **cannot** be reached or is unable to resolve an issue with a Cummins® product.

U.S. and Canada

1-800-CUMMINS™ (1-800-286-6467)

Routine Service and Parts

General Information

Personnel at Cummins Authorized Repair Locations can assist you with the correct operation and service of your system. Cummins has a worldwide service network of more than 5,000 Distributors and Dealers who have been trained to provide sound advice, expert service, and complete parts support. Check the telephone directory, refer to the directory in this section, or the Service Locator at www.cummins.com for the nearest Cummins Authorized Repair Location.

Cummins is pleased to announce the availability of a parts catalog compiled specifically for you. Unlike the generic versions of parts catalogs that support general high volume parts content; Cummins Customized The catalog cover, as well as the content, is customized with

you in mind. You can use it in your shop, at your worksite, or as a coffee table book in your RV or boat. The cover contains your name, company name, address, and telephone number.

This new catalog was designed to provide you with the exact information you need to order parts for your engine. This will be valuable for customers that do not have easy access to Cummins QuickServe Online.

Additional Features of the Customized Catalog include:

- Engine Configuration Data
- Table of Contents
- Separate Option and Parts Indexes
- Service Kits (when applicable)
- ReCon Part Numbers (when applicable)

Ordering the Customized Parts Catalog

Ordering by Telephone

- North American Distributors, Original Equipment Manufacturers and Cummins Factory personnel order by calling Iron Mountain Fulfillment Services (IMFS) at 1-800-646-5609.
- International Distributors and Original Equipment Manufacturers order the CPC from their regional Cummins Parts Distribution Centers (PDC).
- International PDC orders are called into Iron Mountain at (++) 630-283-2420.
- Retail Credit Card Orders require a 2 step ordering process.

Ordering On-Line

Access the Cummins QSOL store at <https://store.cummins.com>

- Find the Customized Parts Catalog button located on the left of the homepage
- Select format. Your Price is also shown here
- Finalize Shopping Cart and Check Process as described on the website

North America call Iron Mountain Fulfillment Services (IMFS) at 800-646-5609, International customers call (++) 630-283-2420. Provide IMFS the catalog detail as described on the website. This step is required until we have our On-Line form available.

Trailer Maintenance

The Importance of Maintenance

Good maintenance is essential for safe, economical and trouble-free operation. It also helps reduce pollution.

Difficult or technically intensive tasks are best handled by your service dealer, or other qualified mechanics. To ensure the best quality and reliability, use only genuine dealer parts for repair or replacement. Use of other manufacturer's parts may void your warranty.

Preventive Maintenance Safety

Some of the most important safety precautions are as follows. However, we cannot warn you of every conceivable hazard that can arise while performing maintenance. Only you can decide whether or not you should perform a given task.

SAFETY PRECAUTIONS

- Turn off engine before you begin maintenance or repairs. This will eliminate several potential hazards.
- To reduce possibility of fire or explosion, be careful when working around fuel tank. Keep cigarettes, sparks and flames away from all fuel related parts.
- For job site use – consult local and state regulations for highway towing restrictions.
- Do Not tow on roads or highways with fuel or water in the trailer or pump.
- Check that safety chains have enough slack to permit sharp turns, not dragging on the pavement. They should cross under the tongue to prevent tongue from dropping on road hitch fails.

Tires

Check to ensure that the tires are properly inflated. Inflation pressure is written on the side wall of the tire. Under-inflation of the tires can cause swaying of the trailer while towing, as well as tire failure. Carefully inspect the tires for any nails, screws or other objects penetrating the wall of the tire. Check the torque (90 ft-lbs.) of the lug nuts on all wheels, prior to pulling the trailer behind the vehicle. The tires have a load rating, equivalent to the trailer weight, for safety.

Brakes (When Equipped)

Electric Brakes

Electric brakes, standard on most models, require that the tow vehicle be equipped with a controlling device, and additional wiring for electrical power. Typically, the control box is installed within reach of the driver.

Hydraulic Surge Brakes

Surge inertia brakes are an independent hydraulically activated braking system, activated by the inertia of the trailer when the towing vehicle stops. This style of brake only works when the vehicle is moving forward.

Lights (When Equipped)

Check to ensure that both rear lights illuminate when energized, and brighten up when the brake pedal is depressed. Replace any light that does not operate properly prior to pulling the trailer behind a vehicle. Make sure all reflectors are securely mounted.

Jackstand

When the unit is not in service, physically rotate the top wind jack stand throughout the entire travel, allowing the weight of the trailer to be moved by the jack stand.

When the unit is not in service, physically move all stationary jack stands, ensuring freedom of movement inside the bracket. Remove, clean and lubricate the locking bolts every 6 months to ensure proper operation of the bolts.

	WARNING
Jackstands (or stabilizers) ARE NOT to be used to jack up the trailer to change tires, work on the axles, or perform any work on the trailer, pump or engine.	
Jackstands are <u>not intended to be used in this way</u> and are not designed to support the entire weight of the assembled unit.	

Miscellaneous Items

Ensure all brackets, hold down bolts, containers, hoses, etc. are properly secured prior to moving the trailer with a vehicle.

The following trailer maintenance guidelines are intended to assist the operator in preventive maintenance.

Trailer Brakes

Properly functioning brake shoes and drums are essential to ensure safety. The brakes should be inspected the first 200 miles of operation. This will allow the brake shoes and drums to seat properly. After the first 200 mile interval, inspect the brakes every 3,000 miles. If driving over rough terrain, inspect the brakes more frequently.

Electric Brakes

Electrically actuated brake (Figure 6-K) are similar to hydraulic brakes. The basic difference is that hydraulic brakes are actuated by an electromagnet. Listed below are some of the advantages that electric brakes have over hydraulic brakes:

- Brake system can be manually adjusted to provide the corrected braking capability for varying road and load conditions.
- Brake system can be modulated to provide more or less braking force, thus easing the brake load on the towing vehicle.
- Brake system has very little lag time between the time the vehicle's brakes are actuated and the trailer's brakes are actuated.
- Brake system can provide an independent emergency brake system. Remember to properly synchronize the tow vehicle's braking to the trailer's braking, can only be accomplished by road testing. Brake lockup, grabbiness or harshness is due to lack of synchronization between the tow vehicle and the trailer being towed or under-adjusted brakes.

Before any brake synchronizations adjustments can be made, the trailer brakes should be burnished-in by applying the brakes 20-30 times with approximately a 20 mph decrease in speed, e.g. 40 mph to 20 mph.

Allow ample time for brakes to cool between applications. This allows the brake shoes to slightly be seated into the brake drum surface.

Figure 6-K displays the major electric brake components that will require inspection and maintenance.

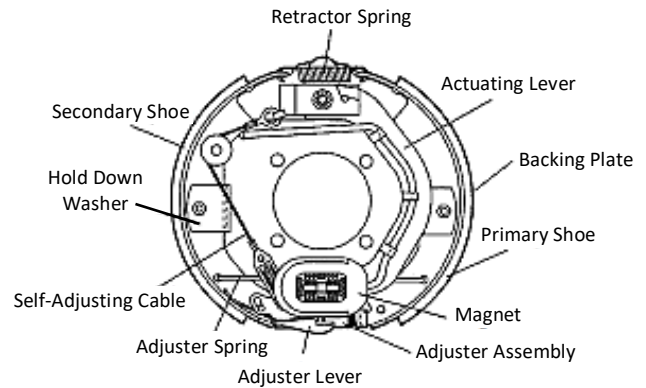

Figure 6-K. Electric Brake Components

Breakaway Brake

Breakaway Battery

This battery supplies the power to operate the trailer brakes if the trailer uncouples from the tow vehicle. Be sure to check, maintain and replace the battery according to the battery manufacturer instructions.

Breakaway Switch

This switch causes the breakaway battery to operate the electric brakes if the trailer uncouples from the tow vehicle. The pull cable for the pull pin is connected to the tow vehicle, and the switch is connected to the trailer.

To check for proper functioning of the switch, battery and brakes, you must pull the pin from the switch and confirm that the brakes apply to each wheel. You can do this by trying to pull the trailer with the tow vehicle, after pulling the pin. The trailer brakes may not lock, but you will notice that a greater force is needed to pull the trailer.

WARNING

If electric breakaway brakes do not operate when trailer is uncoupled from the tow vehicle, death or serious injury can occur.

Check emergency breakaway brake system **before** each tow.

Tow Vehicle Operated Electric Brakes

The electric brakes that operate in conjunction with the tow vehicle brakes must be “synchronized” so that braking is properly distributed to the tow vehicle brakes and the trailer brakes.

For proper operation and synchronization, read and follow the axle/brake and the brake controller manufacturers’ instructions. To make certain an electrically-operated braking system will function properly, you must have your dealer inspect the magnets at least once a year, or each 12,000 miles. See the brake manufacturers’ manual for wear and latest inspection instructions.

If brakes are not working correctly reference Table 6B.

Table 6B. Electric Brake Troubleshooting		
Symptom	Possible Cause	Solution
No Brakes or Intermittent Brakes	Open circuits or broken wires?	Find and correct
	Short circuits?	Find and correct
	Faulty controller?	Find and correct
	Loose connections?	Find and correct
	Ground wire secure?	Find and correct
Weak Brakes or Brakes Pull to One Side	Grease or oil on magnets or linings?	Clean or replace
	Connections corroded?	Clean and correct cause of corrosion
	Brake drums scored or grooved?	Machine or replace
	Brakes synchronized?	Correct

Table 6B. Electric Brake Troubleshooting		
Locking Brakes	Brake components loose, bent or broken?	Replace components
	Brake drums out-of-round?	Replace
Noisy Brakes	System lubricated?	Lubricate
	Brake components correct?	Replace and correct
Dragging Brakes	Brake lining thickness incorrect or not adjusted correctly?	Install new shoes and lining
	Wheel bearings adjusted correctly?	Adjust

Adjustable Channel

Your trailer may be equipped with an adjustable channel (Figure 6-L) that allows the coupler to be raised or lowered to a desired height. Periodically check the channel bolts for damage or loosening.

NOTICE

When replacing channel mounting hardware (nuts, bolts and washers), **Never** substitute substandard hardware. Pay close attention to *bolt length* and *grade*. **Always** use manufacturer’s recommended parts when replacing channel mounting hardware.

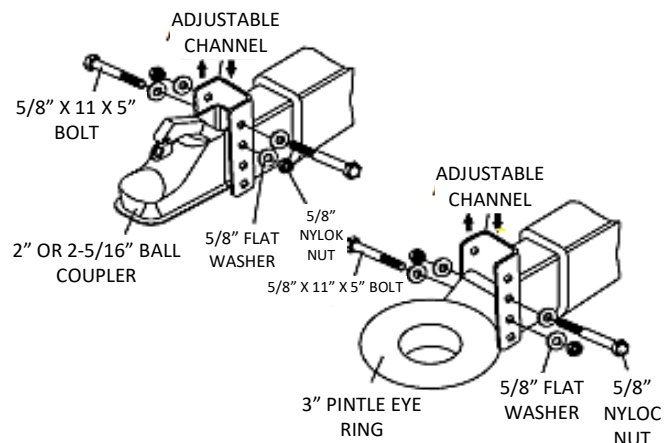



Figure 6-L. Adjustable Channel

Wheel Bearings

Wheel bearings (Figure 6-M) must be inspected and lubricated once a year or 12,000 miles to insure safe operation of your trailer. If trailer wheel bearings are immersed in water, they must be replaced.

 DANGER
<p>If trailer wheels are under water for a long period of time, wheel bearings may fail. If this is the case, service wheel bearings immediately.</p> <p>The possibility exists of the wheels falling off causing equipment damage and severe bodily harm even death!</p>

If the trailer has not been used for an extended amount of time, have the bearings inspected and packed more frequently, at least every six months and prior to use.

Follow the steps below to disassemble the wheel hub and service the wheel bearings. See Figure 6-M.

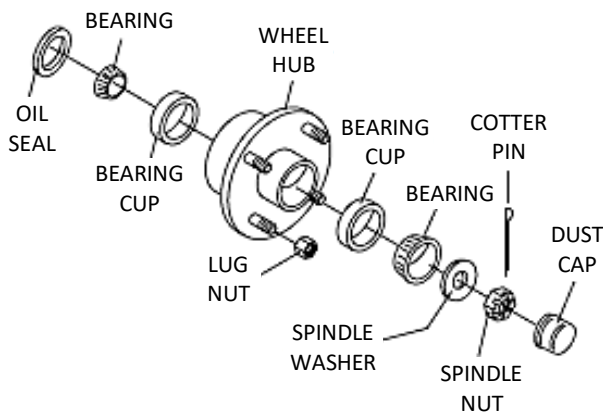

Figure 6-M. Wheel Hub Components

- After removing the dust cap, cotter pin, spindle nut and spindle washer, remove the hub to inspect the bearings for wear and damage.
- Replace bearings that have flat spots on rollers, broken roller cages, rust or pitting. Always replace bearings and cups in sets. The inner and outer bearings are to be replaced at the same time.
- Replace seals that have nicks, tears or wear.

- Lubricate the bearings with a high quality EP-2 automotive wheel bearing grease.

Wheel Hub Adjustment

Every time the wheel hub is removed and the bearings are reassembled, follow the steps below to check the wheel bearings for free running and adjust.

- Turn the hub slowly, by hand, while tightening the spindle nut until you can no longer turn the hub by hand.
- Loosen the spindle nut just until you are able to turn it (the spindle nut) by hand. Do not turn the hub while the spindle nut is loose.
- Install a new cotter pin through the spindle nut and axle.
- Check the adjustments. Both the hub and the spindle nut should be able to move freely (the spindle nut motion will be limited by the cotter pin).

DANGER
<p>Never crawl under the trailer unless it is on firm and level ground and resting on properly placed and secured jackstands.</p> <p>The possibility exists of the trailer falling thus causing equipment damage and severe bodily harm even death!</p>

 DANGER
<p>When performing trailer inspection and maintenance activities, you must jack up the trailer using jacks and jackstands.</p> <p>When jacking and using jackstands, place them so as to clear wiring, brake lines, and suspension parts (i.e., springs, torsion bars). Place jacks and jackstands inside of the perimeter strip on the supporting structure to which the axles are attached.</p>

DANGER

Improper weld repair will lead to early failure of the trailer structure and can cause serious injury or death.

Do Not repair cracked or broken welds unless you have a certified welder perform the repair. If not, have the welds repaired by your dealer.



WARNING

If the trailer is involved in an accident, have it inspected immediately by qualified personnel. In addition, the trailer should be inspected annually for signs of wear or deformations.

Re-torque wheel nut torque requirements on new trailers at 50 miles.

Your trailer brakes should be adjusted between 250 to 300 miles after all of the brake components have seated. Since driving conditions and areas vary you should re-check brakes adjustments at a minimum of 3,000 miles.

Your axles are equipped with the Rockwell American Posi-lube system which provides for lubricating the hubs at a special grease fitting. This option allows grease to flow through specially machined axle spindles, which have been drilled to allow the grease to be passed from the fitting to the inner bearing and back out through the outer bearing.

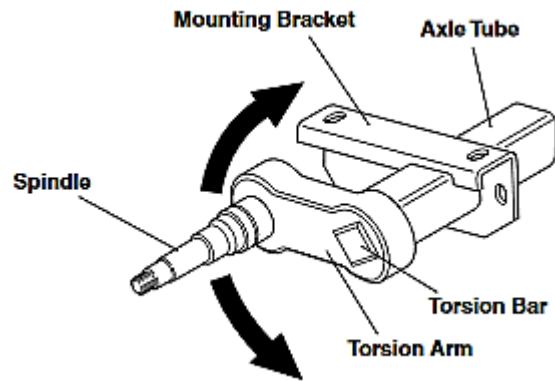

Figure 6-N. Leaf Suspension Components

Never crawl under the trailer unless it is on firm and level ground and resting on properly placed and secured jackstands.



DANGER

Worn or broken suspension parts can cause loss of control, damage to equipment and severe bodily injury, even death!

Check suspension regularly.

POSI-LUBE LUBRICATION PROCEDURE

1. Remove the rubber cap at end of the grease cap.
2. Using a standard grease gun place the tip onto the grease fitting at the end of the spindle.
3. Pump the grease into the fitting as you continue pressure you will notice the old grease coming out at the cap. When you begin to see the new grease, remove the gun and clean off any excess and replace the rubber cap.

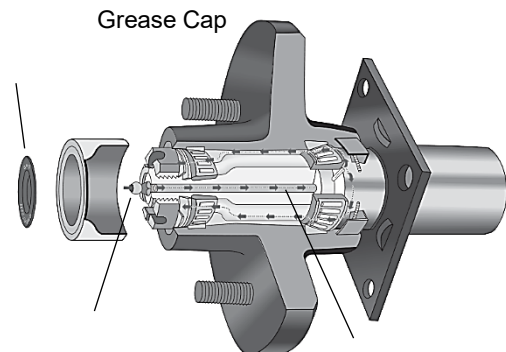

Pump Troubleshooting

Table 7A. Troubleshooting (Pump)

Symptom	Possible Problem	Solution
Pump fails to prime – low vacuum	Insufficient product at inlet (submergence)?	Lower strainer deeper in sump
	Pump drain valve left open?	Close drain valve
	Priming chamber valve closed?	Open priming chamber valve
	Speed too low?	Increase within recommended limits
	Air leak on suction side?	Fix leaks
	Air lock?	Vent air/install air release valve
	Discharge non return valve not seating?	Clear obstruction/check for wear
	Venturi or priming chamber bumper plugged?	Clear any obstructions
	Mechanical seal leaking?	Check and repair/replace as required
Pump fails to prime – high vacuum	Strainer clogged?	Clean strainer
	Excessive suction lift?	Lower if possible or select larger piping
Pump takes a long time to prime	Speed too low?	Increase within recommended limits
	High suction lift and/or long hose length?	Reduce if possible
	Air leak on suction side?	Fix leaks
	Discharge check valve obstructed or worn?	Clear obstruction/check for wear
Pump fails to hold prime when turned off	Worn air compressor or venturi?	Repair/replace
	End of hose/strainer out of liquid?	Check pipe/strainer submergence
	Discharge check valve obstructed or worn?	Clear obstruction/check for wear
	Air leak on suction side of pump?	Fix leaks
	Priming chamber non return valve obstructed?	Clear obstruction/check for wear
Reduced Performance	Vortexing / improper submergence?	Lower strainer deeper in sump
	Air leaks on suction side?	Clear any obstructions
	Strainer or impeller partially clogged?	Lower if possible or select larger piping
	Excessive suction lift?	Increase within recommended limits
	Speed too low?	Lower if possible or select larger piping
	Discharge head too high?	Check and adjust / repair as required
	Pump internals worn?	Adjust / replace as necessary
Pump overheating	Strainer clogged?	Clear any obstructions
	Cavitation (Improper suction design)?	Correct suction problems
	Discharge head too high?	Lower if possible or select large piping
	Pump internals worn?	Check and adjust/repair
	Air lock?	Vent air/install air release valve

Table 7A. Troubleshooting (Pump Continued)

Symptom	Possible Problem	Solution
Excessive pump vibration or noise	Material lodged in impeller (out of balance)?	Clear any obstructions
	Discharge head too high?	Lower if possible or select large piping
	Cavitation (improper suction design)?	Correct suction conditions
	Misalignment?	Align all rotating parts
Premature mechanical seal failure	Inadequate lubrication?	Regrease or refill with oil
	Loss of lubrication?	Check / replace lip seal
	Piping not properly supported?	Provide suitable bracing and supports
	Cavitation (improper suction design)?	Correct suction problems
	Misalignment?	Align all rotating parts
	Discharge head too high?	Lower if possible or select large piping
Liquid discharging	Incompatibility with liquid being pumped?	Check pumping liquid properties
	Float obstructed or damaged?	Clean or replace.
	Priming chamber bumper obstructed or worn?	Clean or replace.

Control Panel Troubleshooting

Table 7B. Troubleshooting Control Panel

Symptom	Possible Problem	Solution
Control system does not perform self-test	Tripped overcurrent protection?	Correct fault, replace or reset overcurrent
	Faulty connection to battery?	Check battery connections
Control system performs normal self-test, engine cranks, runs and shuts down	Only Battery LED illuminated	Check battery connections
	Only Oil Pressure LED Illuminated	Correct low oil pressure condition or faulty switch, correct wiring fault
	Only Temperature LED Illuminated	Correct overheating condition or faulty
	Only Aux LED Illuminated?	If applicable Correct fault condition (i.e. v-belt, coolant)
	All normally closed shutdowns illuminate for one second (control system reset)?	Add suppressor diodes, protect from nearby lightning strikes, shield induced spikes from other equipment, add electric motor control relay

Engine Troubleshooting

Troubleshooting Procedures and Techniques

General Information

This guide describes some typical operating problems, their causes, and some acceptable corrections to those problems. Unless noted otherwise, the problems listed are those which an operator can diagnose and repair.

 WARNING
<p>Performing troubleshooting procedures NOT outlined in this section can result in equipment damage or personal injury or death. Troubleshooting must be performed by trained, experienced technicians. Consult a Cummins Authorized Repair Location for diagnosis and repair beyond that which is outlined, and for symptoms not listed in this section. The troubleshooting procedures listed in this manual are some of the most typical symptoms. For other symptoms please <u>refer to the engine O&M Manual</u>. Before beginning any troubleshooting, <u>refer to General Safety Instructions in the engine O&M Manual</u> in addition to those listed below. This manual is not a substitute for the engine manufacturer's O&M Manual.</p>

Follow the suggestions below for troubleshooting:

- Study the complaint thoroughly before acting
- Refer to the engine system diagrams
- Do the easiest and most logical things first
- Find and correct the cause of the complaint

General Safety Instructions

Important Safety Notice

Read and understand the safety information and precautions before performing any repair or operating equipment. This procedure contains general safety precautions that must be followed to provide personal safety. Always follow procedures to mitigate safety concerns.

Work Environment

Follow these recommended practices when servicing products:

- **Always** follow on-site safety requirements.
- **Always** follow local training, certification, authorization, and specific customer requirements. Do **not** work on products unless proper training has been completed to allow safe repair completion. Do **not** operate equipment unless proper training has been completed to allow safe operation.
- Work in a well-ventilated area away from ignition sources.
- If adverse weather conditions are present, take appropriate safety precautions when performing work.
- **Always** be aware of hazardous conditions that may exist in the work environment.

Best Practices

Follow these recommended practices when servicing or operating equipment.

- **Always** wear protective glasses and protective shoes.
- Remove rings, watches, long jewelry, or metallic items.
- **Do not** wear loose fitting or torn clothing, jewelry, long hair, etc. These increase the risk for personal injury.
- **Do not** perform any repairs, or operate equipment, when fatigued or impaired due to drugs or alcohol.
- **Always** use tools that are in good condition.
- **Do not** work on equipment with the key switch ON or that is running unless otherwise directed by troubleshooting procedures.
- If any work must be performed while the key switch is ON or the unit is running, use extreme caution around hot components, moving parts, etc.
- Exercise caution when working on products that have just been turned off. Hot parts may cause burns or ignite or melt common materials.
- **Do not** bleed the fuel system of a hot engine. Contact with hot manifolds or other components can cause a fire.
- **Do not** attempt to rotate the crankshaft by pulling or prying on the fan. Only use proper engine barring techniques.

- **Do not** lift components that weigh 23 kg [50 lb.] or more. Use mechanical help or seek assistance.
- Exercise caution when working around rotating parts. Rotating parts can cause cuts, mutilation, or strangulation.
- Exercise caution when working on electrical components. High voltages can cause serious injury or death.
- Relieve system pressure as instructed before removing or disconnecting lines, fittings, or related items.
- **Always** test for pressure leaks as instructed.
- **Always** torque fittings and connections to the required specifications. Over or under tightening can damage threads and create leaks.
- **Always** use the same fastener part number, or equivalent, when replacing fasteners.

Perform the following prior to beginning work on any products:

- Shutdown the equipment unless otherwise directed by troubleshooting procedures.
- **Always** allow the product to cool.
- **Always** make sure the product is properly supported by blocks or stands. Do **not** work on a product supported **only** by lifting jacks or hoists.
- Disconnect the battery unless otherwise directed by troubleshooting procedures.
- Disconnect the starting motor, if equipped, unless otherwise directed by troubleshooting procedures.
- Place a "Do NOT Operate" tag in the operator area or near the product controls.
- Become familiar with the tools required for performing the task at hand and how to use those tools correctly.
- Use only genuine Cummins® or Cummins® Recon replacement parts as instructed.

Personal Protective Equipment (PPE)

To reduce the possibility of personal injury, personal protective equipment (PPE) should be utilized. Various types of PPE are listed below. Use proper judgment to determine which types of PPE are required for a given task. **Always** meet on-site safety regulations for required PPE. Proper maintenance of safety equipment **must** be practiced. Integrity of safety equipment **must** be checked to ensure equipment functionality is maintained.

- Eye protection
- Foot protection
- Head and face protection
- Hand protection
- Hearing protection
- Protective clothing
- Respiratory protection
- Fall protection

Engine Difficult to Start or Will Not Start (Exhaust Smoke)

Cause	Correction
STEP 1 Starting procedure is not correct OK Go to Next Step Verify the correct starting procedure. Refer to Procedure 101-018 in Section 1.
STEP 2 Fuel level is low in the tank OK Go To Next Step Fill the supply tank. Refer to equipment manufacturer service information.
STEP 3 Fuel grade is not correct for the application or the fuel quality is poor OK Go to Next Step Operate the engine from a tank of known high quality fuel. Refer to Procedure 018-002 in Section V.
STEP 4 Electronic fault codes are active or high counts of inactive fault codes OK Go To Next Step Review instructions for reading active fault codes.
STEP 5 Starting aid, if necessary for cold weather, is malfunctioning OK Go To Next Step Check for correct operation of the cold weather starting aid. Refer to Procedure 101-004 in Section 1 or the equipment manufacturer service information.
STEP 6 Engine block heater is malfunctioning, if equipped OK Go To Next Step Check the electrical sources and wiring to the cylinder block heater. Replace the block heater, if necessary. Refer to equipment manufacturer service information.
STEP 7 Fuel heater is malfunctioning, if equipped OK Go To Next Step Check the fuel heater and replace, if necessary. Refer to equipment manufacturer service information.
STEP 8 Battery voltage is low OK Go To Next Step Check the batteries and the unswitched battery supply circuit. Refer to equipment manufacturer service information.
STEP 9 Keyswitch circuit is malfunctioning OK Go To Next Step Check the vehicle keyswitch circuit. Refer to equipment manufacturer service information.

Engine Difficult to Start or Will Not Start (Exhaust Smoke)

Cause	Correction
<p>STEP 10 Engine cranking speed is too slow</p> <p>OK Go To Next Step</p>	<p>..... Check the engine cranking speed with a handheld tachometer or electronic service tool. Determine if the cranking speed is slower than 120 rpm.</p>
<p>STEP 11 Vehicle parasitics are excessive</p> <p>OK Go To Next Step</p>	<p>..... Check the vehicle for brakes dragging, transmission malfunction, cooling fan operation cycle time, and engine-driven units. Refer to equipment manufacturer service information.</p>
<p>STEP 12 Fuel Leak</p> <p>OK Go To Next Step</p>	<p>..... Check the fuel lines, fuel connections, and fuel filters for leaks. Check the fuel lines to the supply tanks. Refer to equipment manufacturer service information.</p>
<p>STEP 13 Air in fuel system</p> <p>OK Go To Next Step</p>	<p>..... Check for air in the fuel system. Tighten or replace the fuel connections, fuel lines, fuel tank standpipe, and fuel filters as necessary.</p>
<p>STEP 14 Air intake system restriction is above specification</p> <p>OK Go To Next Step</p>	<p>..... Check the air intake system for restriction. Replace the air filter and inlet piping as necessary. Refer to Procedure 010-058 in Section 4 and Procedure 010-059 in Section 4.</p>
<p>STEP 15 Fuel filter or fuel suction line is restricted</p> <p>OK Go To Next Step</p>	<p>..... Replace the fuel filter. Check the fuel suction line for restriction. Refer to Procedure 007-002 in Section 4 for fuel filter replacement and the equipment manufacturer service information for suction line restriction.</p>
<p>STEP 16 Fuel supply is not adequate</p> <p>OK Go To Next Step</p>	<p>..... Check the flow through the filter to locate the source of the restriction. Refer to Procedure 006-074 in Section 5 and the equipment manufacturer service information for suction line restriction.</p>
<p>STEP 17 Contact Cummins® Authorized Repair Facility</p>	

Engine Difficult to Start or Will Not Start (No Exhaust Smoke)

Cause	Correction
STEP 1 Starting procedure is not correct Verify the correct starting procedure. Refer to Procedure 101-014 in Section 1.
OK Go To Next Step	
STEP 2 Fuel level is low in the tank Fill the supply tank. Refer to equipment manufacturer service information.
OK Go To Next Step	
STEP 3 Fuel grade is not correct for the application or the fuel quality is poor Operate the engine from a tank of known high quality fuel. Refer to Procedure 018-002 in Section V.
OK Go To Next Step	
STEP 4 Electronic fault codes are active or high counts of inactive fault codes Review instructions for reading active fault codes. Refer to equipment manufacturer service information or contact a Cummins® Authorized Repair Location, if fault codes are active.
OK Go To Next Step	
STEP 5 Original equipment manufacturer (OEM) engine protection system is malfunctioning Isolate the OEM engine protection system. Follow the OEM service manual instructions to check for a malfunction
OK Go To Next Step	
STEP 6 Battery voltage is low Check the batteries and the unswitched battery supply circuit. Refer to equipment manufacturer service information.
OK Go To Next Step	
STEP 7 Keyswitch circuit is malfunctioning Check the vehicle, equipment, or vessel keyswitch circuit. Refer to equipment manufacturer service information or Contact a Cummins® Authorized Repair Location.
OK Go To Next Step	
STEP 8 Battery voltage supply to the electronic control module (ECM) is low, interrupted, or open Check the battery connections. Refer to equipment manufacturer service information.
OK Go To Next Step	
STEP 9 Moisture in the wiring harness connectors Dry the connector with Cummins® electrical contact cleaner, Part Number 3824510. Refer to equipment manufacturer service information.
OK Go To Next Step	

Engine Difficult to Start or Will Not Start (No Exhaust Smoke)

Cause	Correction
STEP 10 Air in the fuel system OK Go To Next Step Check for air in the fuel system. Tighten or replace the fuel connections, fuel lines, fuel tank standpipe, and fuel filters as necessary.
STEP 11 Engine control module (ECM) is locked up OK Go To Next Step Disconnect the battery cables for 30 seconds. Connect the battery cables and start the engine.
STEP 12 Fuel filter or fuel suction line is restricted OK Go To Next Step Replace the fuel filter. Check the fuel suction line for restriction. Refer to Procedure 006-074 in Section 5 for fuel filter replacement or the equipment manufacturer service information for suction line restriction.
STEP 13 Fuel supply is not adequate OK Go To Next Step Check the flow through the filter to locate the source of the restriction. Refer to Procedure 006-074 in Section 5.
STEP 14 Fuel drain backup OK Go To Next Step Verify the fuel return line is plumbed to the bottom of the fuel tank.
STEP 15 Contact a Cummins® Authorized Repair Facility	

Engine Power Output Low

Cause	Correction
STEP 1 Electronic fault codes are active or high counts of inactive fault codes OK Go To Next Step	Review instructions for reading active fault codes.
STEP 2 Vehicle parasitics are excessive OK Go To Next Step	Check the vehicle for brakes dragging, transmission malfunction, cooling fan operation cycle time, and engine-driven units. Refer to equipment manufacturer service information.
STEP 3 Fuel grade is not correct for the application or the fuel quality is poor OK Go To Next Step	Operate the engine from a tank of known high quality fuel. Refer to Procedure 018-002 in Section V.
STEP 4 Lubricating oil level above specification OK Go To Next Step	Check the oil level. Verify the oil pan capacity. Fill the system to the specified level. Refer to Procedure 007-043 in Section 3.
STEP 5 Engine is operating above recommended altitude OK Go To Next Step	Engine power decreases above recommended altitude. Refer to equipment manufacturer service information.
STEP 6 Tachometer is not calibrated or is malfunctioning OK Go To Next Step	Compare the tachometer reading with a handheld tachometer or an electronic service tool reading. Calibrate or replace the tachometer as necessary. Refer to equipment manufacturer service information.
STEP 7 Intake and exhaust system restricted OK Go To Next Step	Check the intake and exhaust systems for restrictions. Inspect the intake air filter and replace as necessary. Refer to equipment manufacturer service information or contact a Cummins® Authorized Repair Location.
STEP 8 Air intake system restriction is above specification OK Go To Next Step	Check the air intake system for restriction. Replace the air filter and inlet piping as necessary. Refer to Procedure 010-058 in Section 4 and Procedure 010-059 in Section 4.

Engine Power Output Low

Cause	Correction
STEP 9 Air intake or exhaust leaks OK Go To Next Step Check for loose or damaged piping connections and missing pipe plugs. Check the turbocharger and exhaust manifold mounting. Refer to equipment manufacturer service information.
STEP 10 Air leak between the turbocharger and the intake manifold OK Go To Next Step Check for leaks in the air crossover tube, charge air cooler connections, hoses, or through holes in the manifold cover and repair or replace if necessary. Refer to equipment manufacturer service information.
STEP 11 Charge-air cooler is restricted or leaking OK Go To Next Step Inspect the charge-air cooler for air restrictions or leaks. Refer to Procedure 010-027 in Section 4.
STEP 12 Fuel leak OK Go To Next Step Check the fuel lines, fuel connections, and fuel filters for leaks. Check the fuel lines to the supply tanks. Refer to equipment manufacturer service information.
STEP 13 Air in the fuel system OK Go To Next Step Check for air in the fuel system. Tighten or replace the fuel connections, fuel lines, fuel tank standpipe, and fuel filters as necessary.
STEP 14 Fuel supply is not adequate OK Go To Next Step Check the flow through the filter to locate the source of the restriction. Refer to Procedure 006-074 in Section 5.
STEP 15 Fuel return restriction excessive OK Go To Next Step Inspect the fuel return lines for restrictions. Refer to equipment manufacturer service information.
STEP 16 Fuel filter or fuel suction line is restricted OK Go To Next Step Replace the fuel filter. Check the fuel suction line for restriction. Refer to Procedure 006-074 in Section 5 for fuel filter replacement and the equipment manufacturer service information for suction line restriction.
STEP 17 Contact a Cummins® Authorized Repair Facility	

Engine Runs Rough at Idle

Cause	Correction
STEP 1 Engine is cold OK Go To Next Step Allow the engine to warm to operating temperature.
STEP 2 Electronic fault codes are active or high counts of inactive fault codes OK Go To Next Step Review instructions for reading active fault codes.
STEP 3 Engine idle speed is set too low OK Go To Next Step Verify the correct idle speed setting. Increase the idle speed with the idle increment switch or an electronic service tool.
STEP 4 Air in the fuel system OK Go To Next Step Check for air in the fuel system. Tighten or replace the fuel lines, fuel tank standpipe, and fuel filters, as necessary.
STEP 5 Fuel filter or fuel suction line is restricted OK Go To Next Step Replace the fuel filter. Check the fuel suction line for restriction. Refer to OEM engine manual section 4 for fuel filter replacement and the equipment manufacturer service information for suction line restriction.
STEP 6 Fuel supply is not adequate OK Go To Next Step Check the flow through the filter to locate the source of the restriction.
STEP 7 Fuel grade is not correct for the application or the fuel quality is poor OK Go To Next Step Operate the engine from a tank of known high quality fuel. Refer to Procedure 018-002 in Section V in the OEM engine manual.
STEP 8 Fuel supply line or passage restriction between the fuel pump and the injectors OK Go To Next Step Check the fuel supply line or passage for sharp bends or restriction. Contact a Cummins® Authorized Repair Location.

Engine Runs Rough at Idle

Cause

STEP 9

Engine mounts are worn, damaged, or **not** correct

OK

Go To Next Step

STEP 10

Moisture in the wiring harness connectors

OK

Go To Next Step

STEP 11

Contact a Cummins® Authorized Repair Facility

Correction

.....
Check the engine mounts. Refer to equipment manufacturer service information.

.....
Dry the connector with Cummins® electrical contact cleaner, Part Number 3824510. Refer to equipment manufacturer service information.

Engine Shuts Off Unexpectedly or Dies During Deceleration

Cause		Correction
<p>STEP 1 Fuel level is low in the tank</p>	<p>.....</p>	<p>Fill the supply tank. Refer to equipment manufacturer service information.</p>
<p>OK Go To Next Step</p>		
<p>STEP 2 Electronic fault codes are active or high counts of inactive fault codes</p>	<p>.....</p>	<p>Review instructions for reading active fault codes.</p>
<p>OK Go To Next Step</p>		
<p>STEP 3 Moisture in the wiring harness connectors</p>	<p>.....</p>	<p>Dry the connector with Cummins® electrical contact cleaner, Part Number 3824510. Refer to Procedure 101-007 in Section 1 in OEM engine manual.</p>
<p>OK Go To Next Step</p>		
<p>STEP 4 Original equipment manufacturer (OEM) engine protection system is malfunctioning</p>	<p>.....</p>	<p>Isolate the OEM engine protection system. Follow the OEM service manual instructions to check for a malfunction.</p>
<p>OK Go To Next Step</p>		
<p>STEP 5 Battery supply to the engine control module (ECM) is low, interrupted, or open</p>	<p>.....</p>	<p>Check the battery connections, fuses, and unswitched battery supply circuit. Refer to equipment manufacturer service information.</p>
<p>OK Go To Next Step</p>		
<p>STEP 6 Air in the fuel system</p>	<p>.....</p>	<p>Check for air in the fuel system. Tighten or replace the fuel lines, fuel tank standpipe, and fuel filters, as necessary.</p>
<p>OK Go To Next Step</p>		
<p>STEP 7 Contact a Cummins® Authorized Repair Facility</p>		

Engine Starts but Will Not Keep Running

Cause	Correction
STEP 1 Fuel level is low in the tank Fill the supply tank. Refer to equipment manufacturer service information.
OK Go To Next Step	
STEP 2 Fuel grade is not correct for the application or the fuel quality is poor Operate the engine from a tank of known high quality fuel. Refer to Procedure 018-002 in Section V in the engine OEM manual.
OK Go To Next Step	
STEP 3 Battery voltage supply to the control module (ECM) is low, interrupted, or open Check the battery connections. Refer to equipment manufacturer service information.
OK Go To Next Step	
STEP 4 Electronic fault codes are active or high counts of inactive fault codes Review instructions for reading active fault codes. Refer to equipment manufacturer service information or contact a Cummins® Authorized Repair Location.
OK Go To Next Step	
STEP 5 Idle speed is set too low for accessories Check and adjust the low-idle speed adjustment feature with INSITE™ electronic service tool. Contact a Cummins® Authorized Repair Location.
OK Go To Next Step	
STEP 6 Engine-driven units are engaged Disengage engine-driven units. Refer to equipment manufacturer service information.
OK Go To Next Step	
STEP 7 Air in the fuel system Check for air in the fuel system. Tighten or replace the fuel lines, fuel tank standpipe, and fuel filters, as necessary.
OK Go To Next Step	
STEP 8 Fuel filter or fuel suction line is restricted Replace the fuel filter. Check the fuel suction line for restriction. Refer to Section 5 in the OEM engine manual for filter replacement. Contact a Cummins® Authorized Repair Location to troubleshoot suction line restriction.
OK Go To Next Step	
STEP 9 Contact a Cummins® Authorized Repair Facility	

Layout Drawing

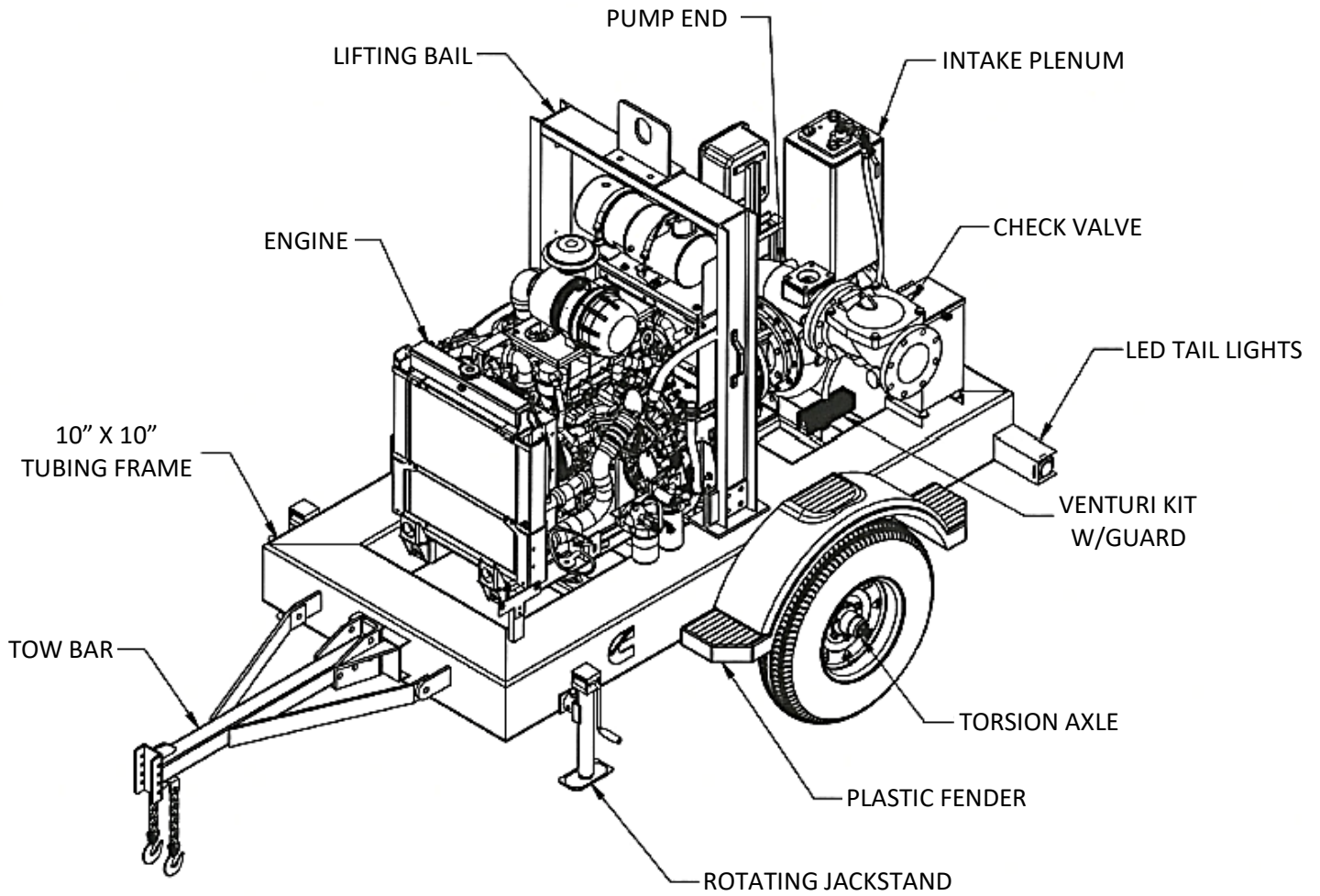

Label Drawing – Driver’s Side Perspective

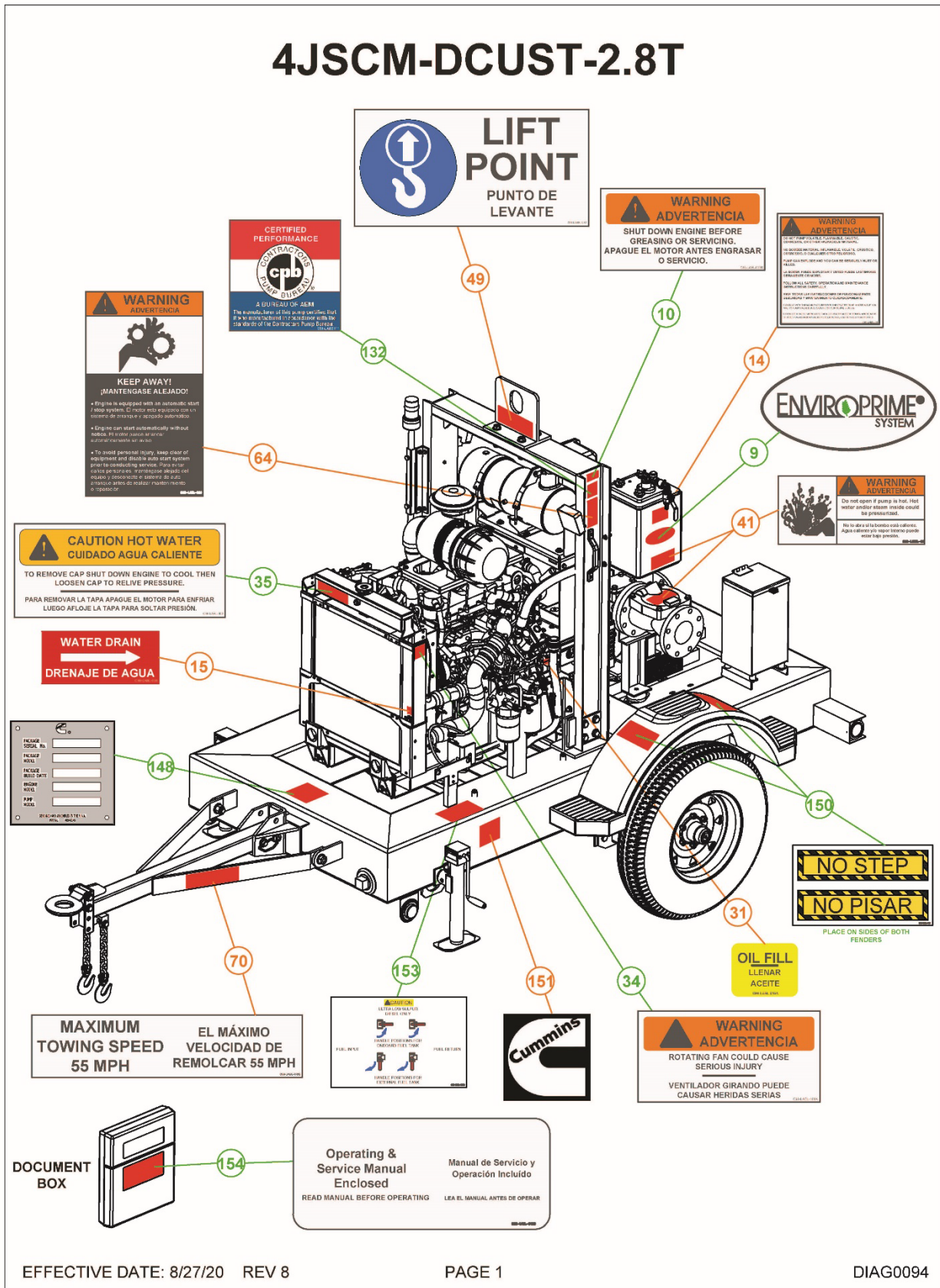

Label Drawing – Passenger Side Perspective

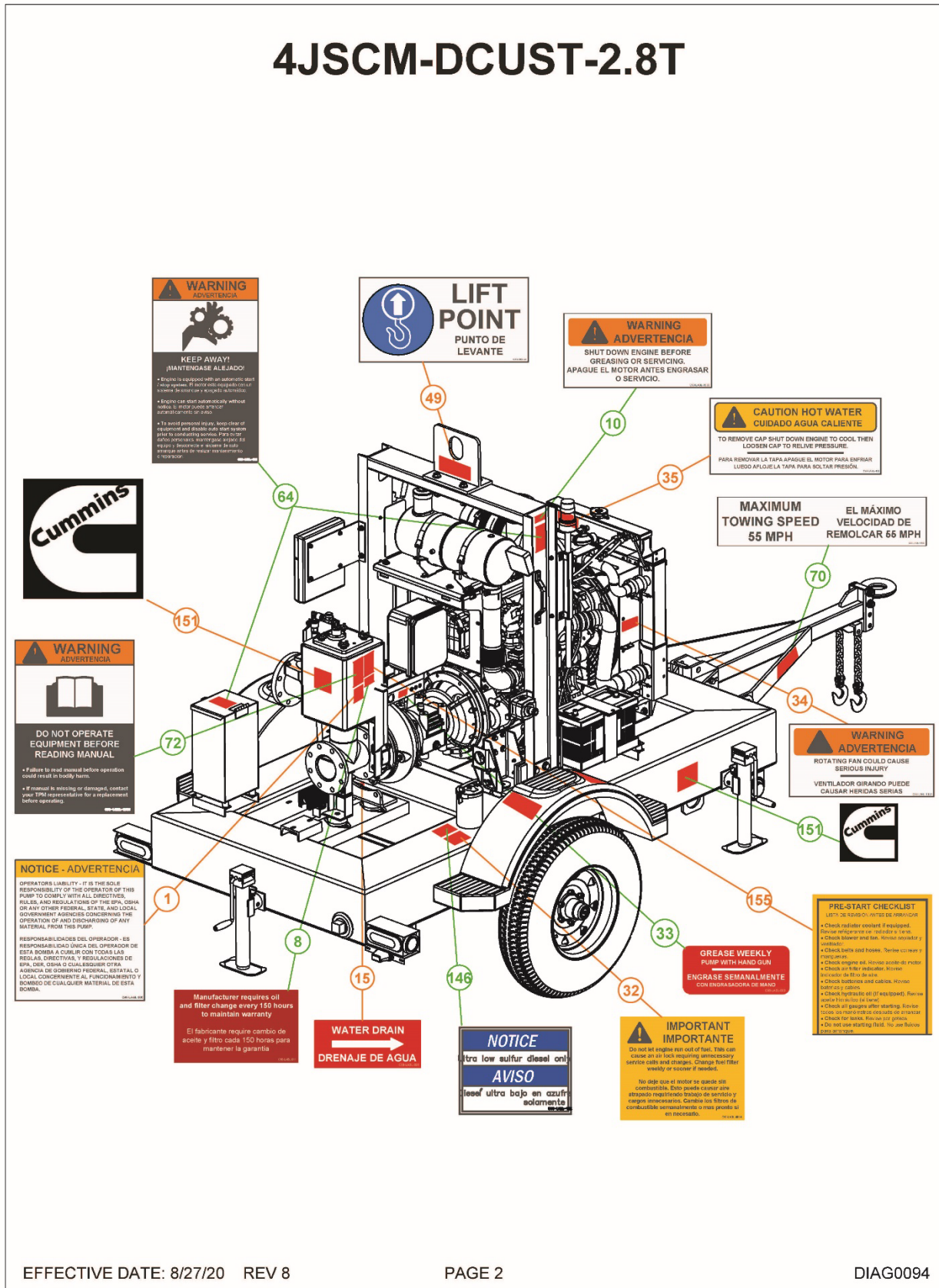

Bill of Material – Labels

QSF4X4			
Item Reference Number	Description	Qty	Part Number
1	Operator's Liability	1	A065N935
8	Mfg. Requirements	1	A065N936
9	Enviroprime	1	A065P001
10	Shut Down Engine	2	A065N937
14	Volatile Material	1	A065N938
15	Water Drain	2	A065N939
31	Oil Fill	2	A065N941
32	Air Lock Warning	1	A065N942
33	Grease Weekly	1	A065N943
34	Rotating Fan	2	A065N944
35	Hot Water	2	A065N945
41	Steam Warning	2	A065N946
49	Lifting Point	2	A065N947
52	Pre-Start Checklist	1	A065N948
64	Auto-Start Warning	3	A065N949
70	Max Towing Speed	2	A065N950
72	Read Manual Warning	1	A065N951
132	CPB – Red, White & Blue	1	A065N952
146	Ultra Low Sulfur Diesel	1	A065N953
148	Cummins PSN Dataplate	1	A064X146
150	No Step / No Pissar – Yellow / Black	4	A065P002
151	Cummins Label – White / Clear	3	A065P003
153	Diesel Fuel Valve Positions	1	A065P004
154	Document Box	1	A065P005
155	Pre-Start Checklist	1	A065P006

QSF4X4 Parts and Assembly

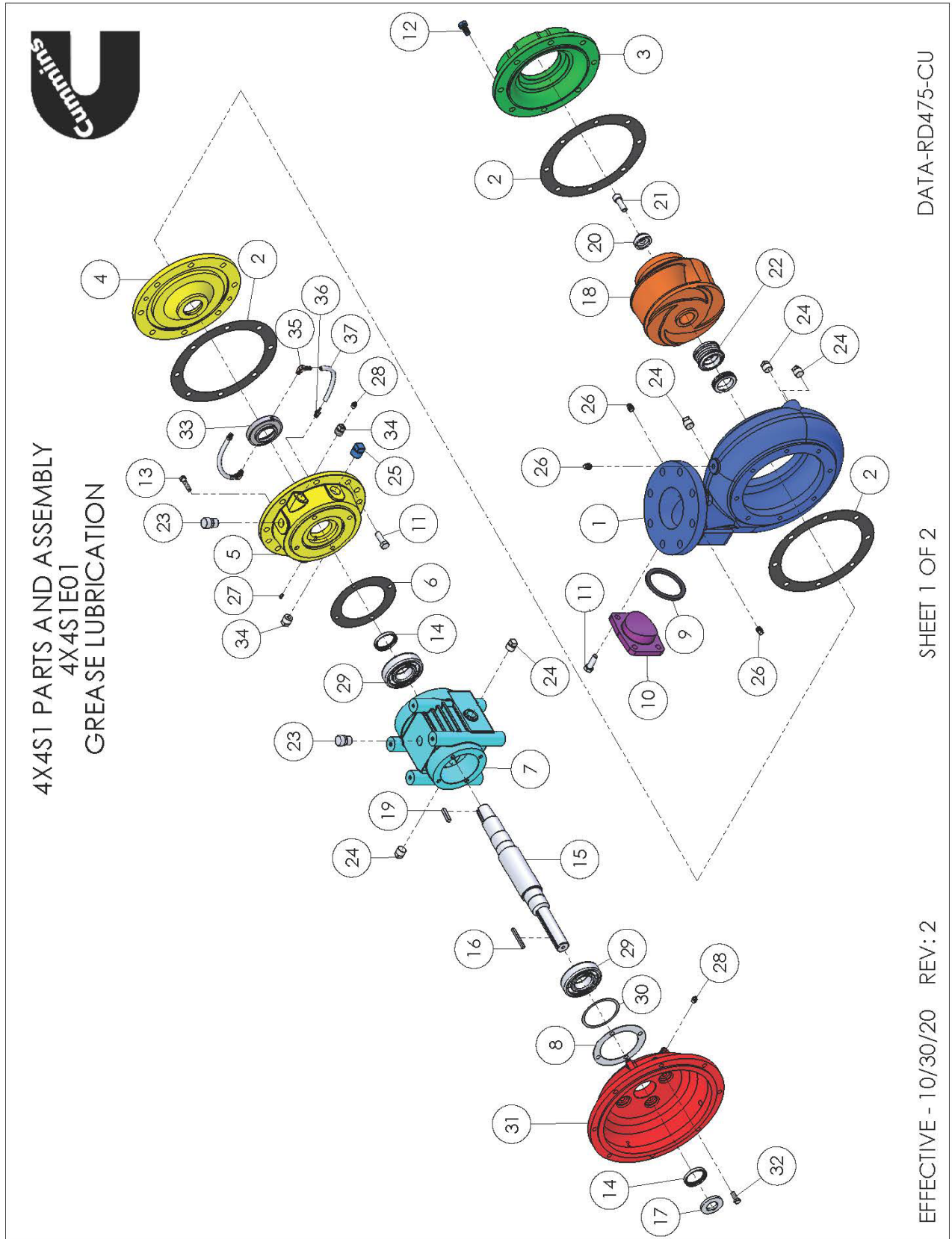

4X4S1 PARTS AND ASSEMBLY
4X4S1E01
GREASE LUBRICATION

DATA-RD475-CU

SHEET 1 OF 2

EFFECTIVE - 10/30/20 REV: 2

Bill of Material – QSF4X4 Parts and Assembly

QSF4X4 Pump Parts			
Item Reference Number	Description	Qty	Part Number
1	VOLUTE, 4X4S1 CI	1	A065E785
2	GASKET, VOLUTE 4X4S1	3	A065E801
3	COVER, SUCT 4X4S1 CI	1	A065E807
4	BACKPLATE, 4X4S1 CI	1	A065E795
5	BRACKET, PUMP 4X4S1 CL30-CI	1	A065E803
6	GASKET, BRKT PUMP 4X4S1	1	A065E798
7	HOUSING, BRG 4X4S1	1	A065E930
8	GASKET, BRG-COVER 4X4S1	1	A065E786
9	GASKET, COVER CL-OUT 4X4S1	1	A065E797
10	COVER, CLEAN 4X4S1 CI	1	A065E784
11	HHCS, 1/2-13 X 1-1/2 USS GR5	12	A065E793
12	SHCS, 1/2-13 X 1 USS	8	A065E802
13	HHCS, 3/8-16 X 1-1/2 USS GR5	4	A065E792
14	SEAL, LIP 1.75 X 2.25 X .313	2	A065E796
15	SHAFT, 4X4S1-A LONG	1	A065E805
16	KEY, SHAFT DRIVE 1/4" X 2-1/2"	1	A065E929
17	DEFLECTOR, 4X4S1 BLK-NIT	1	A065E787
18	IMPELLER, 4X4S1 8.25 DI	1	A065E791
19	KEY, IMP .31 x 1.40" LONG	1	A065E928
20	WASHER, IMP 4X4S1 SS416	1	A065E799
21	SHCS, 1/2-13 X 1-1/2 SS	1	A065E800
22	SEAL, MECH 1-5/8 TYPE 2-JC	1	A065E794
23	BREATHER, 1/2 NPT 6X6S1	2	A065E751
24	PLUG, 1/2 NPT BLK STL	6	A065E739
25	PLUG, 3/4 NPT BLK STL	1	A065E763
26	PLUG, 1/4 NPT BI	3	A065E804

Bill of Material – QSF4X4 Parts and Assembly Continued

Item Reference Number	Description	Qty	Part Number
27	NIPPLE, GREASE 6M-1.00-6M	1	A065E789
28	FITTING, GREASE 1/8	1	A065E777
29	BEARING, BALL SING OPEN	2	A065E788
30	SHIM, BRG .010" 4X4S1 AL	1	A065E806
31	HOUSING, BELL SAE-5 CI 13-1/8" BOLT CENTER	1	A065E931
32	HHCS, 3/8-16 X 1 USS GR5	4	A065E783
33	PLASTIC GREASE RETAINING CUP – 4X4S1	1	A065V338
34	PLUG, 1/2 NPT BLK STL - MODIFIED	2	A065V339
35	FITTING, FUEL 1/8 X 1/4 90	2	A065V340
36	FITTING, FUEL 1/8 X 1/4 STRT	2	A065V341
37	HOSE, GREASE 1/8"	2	A065V342

Air Separation Chamber Assembly

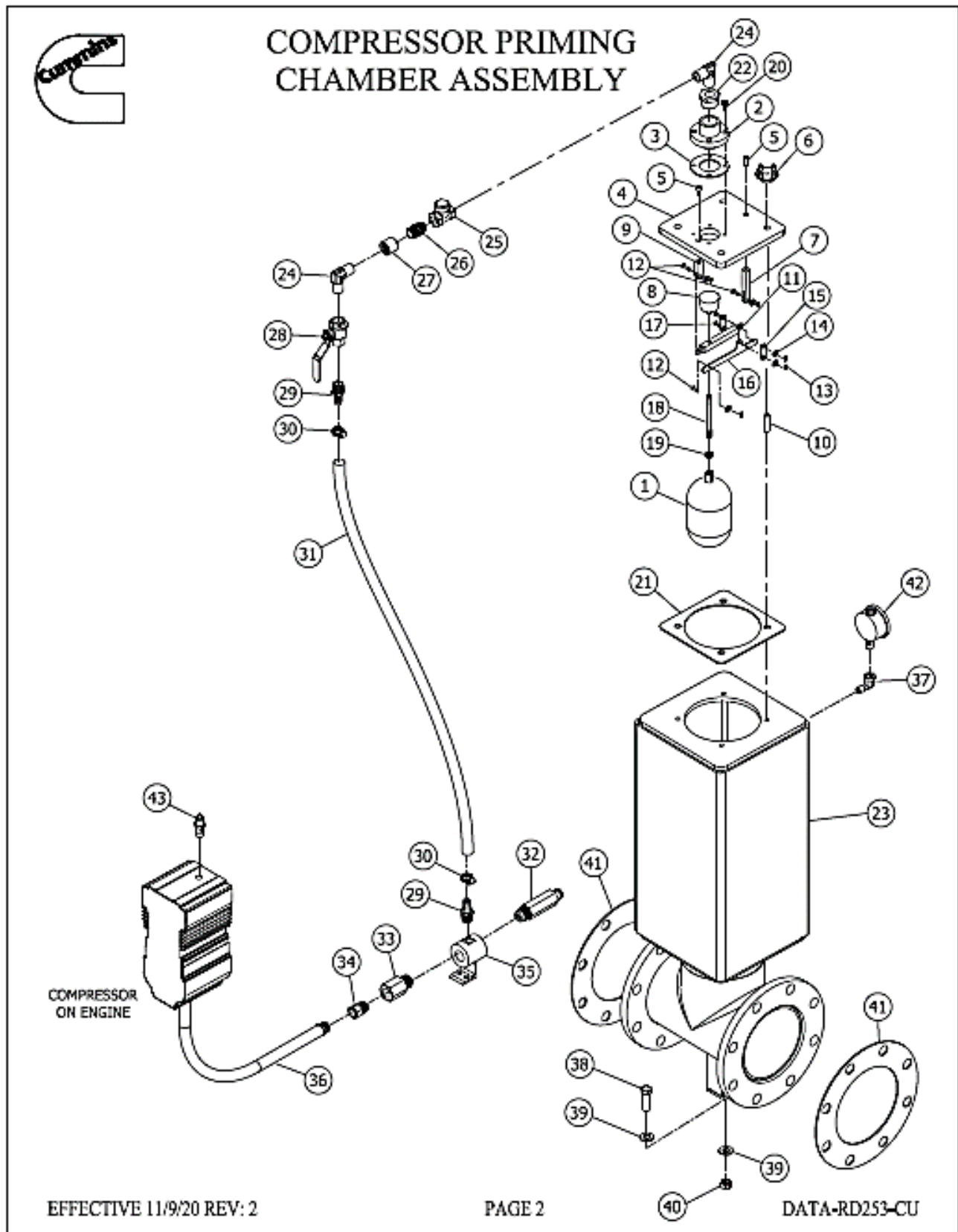

Bill of Material – Air Separation Chamber Assembly

Air Separation Chamber			
Item Reference Number	Description	Qty	Part Number
1	FLOAT, VENT VALVE 2" SS	1	A065E809
2	VALVE, VENT 1" AIR SEPR TOP	1	A065E932
3	GASKET, AIR-SEP TOP	1	A065E933
4	COVER, INTK STD 7-1/4 X 7-1/4	1	A065E810
5	SHCS, 1/4-20 X 1/2 S.S.	2	A065E811
6	WRENCH, 10M-1.5 BRZ	4	A065E812
7	POST, ARM LONG VENT VLV PT	1	A065E813
8	BUMPER, STUD 5/16-18 STUD	1	A065E814
9	POST, PIVOT VAC KVT3.6 SS	1	A065E934
10	STUD, 10M-1.5-45M-OAL 304SS	4	A065E935
11	PIVOT, VENT-VLV LONG ARM	1	A065E936
12	PIN, 3/16 X 5/8 SS18-8	3	A065E937
13	PIN, COTTER 1/16 X 1/2 SS	5	A065E815
14	WASHER, FLAT #10 SS18-8	5	A065E816
15	LINK, 2" VENT VALVE SS	2	A065E817
16	ARM, VENT VALVE LONG SS	1	A065E818
17	PIN, CLEVIS 3/16 X 1/2 SS18-8	2	A065E819
18	ROD, FLOAT 4" COMP SS	1	A065E820
19	NUT, JAM 3/8-16 SS	1	A065E821
20	SHCS, 1/4-20 X 5/8 USS	4	A065E822
21	GASKET, COVER INTK 7-1/4 X 7-1/4	1	A065E938
22	BUSHING, RED 1" X 1/2	1	A065E823
23	PLENUM, 4JSCM INTK COMP	1	A065E824
24	ELBOW, 1/2MNPT X 1/2MNPT HP	2	A065E825
25	VALVE, CHECK 1/2 CONE BRS	1	A065E826
26	NIPPLE, HEX 1/2 NPT	1	A065E940

Bill of Material – Air Separation Chamber Assembly Continued

Item Reference Number	Description	Qty	Part Number
27	COUPLING, MERCH 1/2 NPT BI	1	A065E827
28	VALVE, BALL 1/2" BRS	1	A065E828
29	FITTING, FUEL 1/2 MPT X HB STR	2	A065E941
30	CLAMP, HOSE 1" (24M) 08 SS	2	A065E829
31	HOSE, 1/2 SAE-100R3 BLK	1	A065E830
32	NOZZLE, VENTURI DISCH T3 BRZ	1	A065E942
33	NOZZLE, VENTURI INLET T6	1	A065E831
34	SWIVEL, 1/2 ST INT/EXT PIPE	1	A065E832
35	HOUSING, 1" VENTURI STL	1	A065E943
36	HOSE, ASSY 42" COMP W/FITTINGS	1	A065E944
37	ELBOW, STREET 1/4 X 90DG	1	A065E839
38	HHCS, 1/2-13 X 1-3/4 USS GR5	2	A065E833
39	WASHER, FLAT 1/2 SAE	4	A065E834
40	NUT, NYLOCK 1/2-13 USS	2	A065E835
41	GASKET, FLG 4" ANSI NIT	2	A065E837
42	GAUGE, VAC 2-1/2 SS TPM-LOGO	1	A065E838
43	RELIEF VALVE	1	A065V447

Trailer Assembly

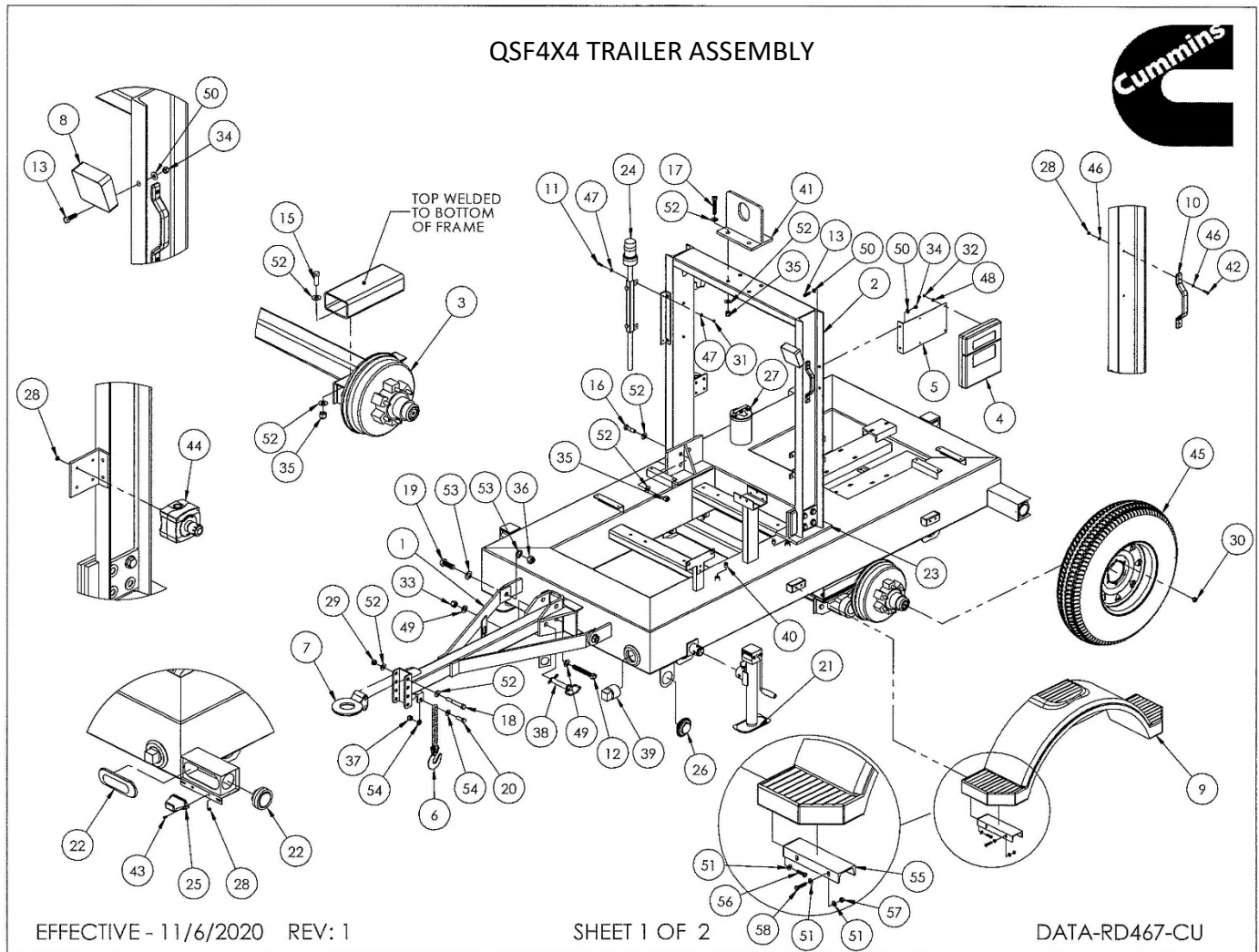

Bill of Material – Trailer Assembly

Item Reference Number	Description	Qty	Part Number
1	6JSCEE/4JSCM FOLDING TONGUE	1	A065E946
2	6JSCEE/4JSCM LIFTING BAIL	1	A065E841
3	AXLE, TORSION 5200 6-LUG EB	1	A065E842
4	BOX, DOCUMENT 8 1/2" X 11"	1	A065E843
5	BRACKET, DOCUMENT BOX SIDE MOUNT	1	A065E947
6	CHAIN, SAFETY 3/8 X 36" W/HOOK	2	A065E844
7	COUPLER, RING 3"	1	A065E845
8	EXTERIOR SPOT LIGHTS OPTILUX LED	2	A065E948
9	FENDER, SING W/STEP PLASTIC 14"-15"	2	A065E949
10	HANDLE, GRAB 1 X 9-1/2 HDPE BLK 2 PER SET	2	A065E846
11	HHCS, 1/4 X 1 SS	4	A065E847
12	HHCS, 3/4-10 X 5-1/2 USS GR8	1	A065E848
13	HHCS, 3/8-16 X 1-1/4 USS GR5	4	A065E849
14	HHCS, 5/16-24 X 1 SAE	8	A065E850
15	HHCS, 5/8 X 1-3/4 GRADE 8	4	A065E851
16	HHCS, 5/8-11 X 2-1/4 GR8	8	A065E852
17	HHCS, 5/8-11 X 3-1/2 GR8	4	A065E853
18	HHCS, 5/8-11 X 4-1/2 GR8	2	A065E854
19	HHCS, 7/8-9 X 2-1/2 USS GR8	2	A065E855
20	HHCS, 9/16-12 X 1-3/4 GR8	1	A065E851
21	JACK, CYLINDER W/ SIDE HANDLE (5,000 LBS)	3	A065E950
22	KIT, LIGHT 6" OVAL LED W/SIDE MARKER	2	A065E951
23	LIFTING BAIL MOUNTING BASE (4JSCM/6JSCEE)	2	A065E952
24	LIGHT, BEACON 12V LED	1	A065E856
25	LIGHT, LICENSE PLATE	1	A065E857
26	LIGHT, SIDE MARKER LED AMBER	2	A065E858
27	NECK, FUEL FILL KIT	1	A065E953

Bill of Material – Trailer Assembly Continued

Item Reference Number	Description	Qty	Part Number
28	NUT, KEP 10-32 SS	10	A065E859
29	NUT, LOCK 5/8-11 2-WAY	2	A065E860
30	NUT, LUG CONE 1/2-20 X 60DG	16	A065E861
31	NUT, NYLOCK 1/4-20 SS	4	A065E862
32	NUT, NYLOCK 1/4-20 USS	4	A065E863
33	NUT, NYLOCK 3/4-10 GR8	1	A065E864
34	NUT, NYLOCK 3/8-16	4	A065E865
35	NUT, NYLOCK 5/8-11 GR8	16	A065E866
36	NUT, NYLOCK 7/8-9 USS GR8	2	A065E867
37	NUT, NYLOCK 9/16-12 GR8	1	A065E868
38	PIN, SWIVEL TOP 7/8 JCKST	1	A065E954
39	PLUG, 3" SQ-HEAD 2/6000 STL	2	A065E869
40	PLUG, 3/8 NPT BLK STL	2	A065E748
41	REMOVABLE LIFTING EYE 6JSCEE/4JSCM	1	A065E870
42	SCREW, MACH 10-32 X 1 SS	4	A065E871
43	SCREW, MACH FLAT 10-32 X 1/2 SS	2	A065E872
44	SWITCH, EMERGENCY STOP	1	A065E955
45	TIRE+WHEEL, 225 15" 6-LUG D	2	A065E873
46	WASHER, FLAT #10 (18-8) SS	8	A065E816
47	WASHER, FLAT 1/4 SAE	8	A065E874
48	WASHER, FLAT 1/4 USS	4	A065E875
49	WASHER, FLAT 3/4 SAE	2	A065E876
50	WASHER, FLAT 3/8 SAE	6	A065E877
51	WASHER, FLAT 5/16 SAE	8	A065E878
52	WASHER, FLAT 5/8 ZINC SAE	36	A065E879
53	WASHER, FLAT 7/8" SAE SS	4	A065E880
54	WASHER, FLAT 9/16 USS	2	A065E881

Engine Views

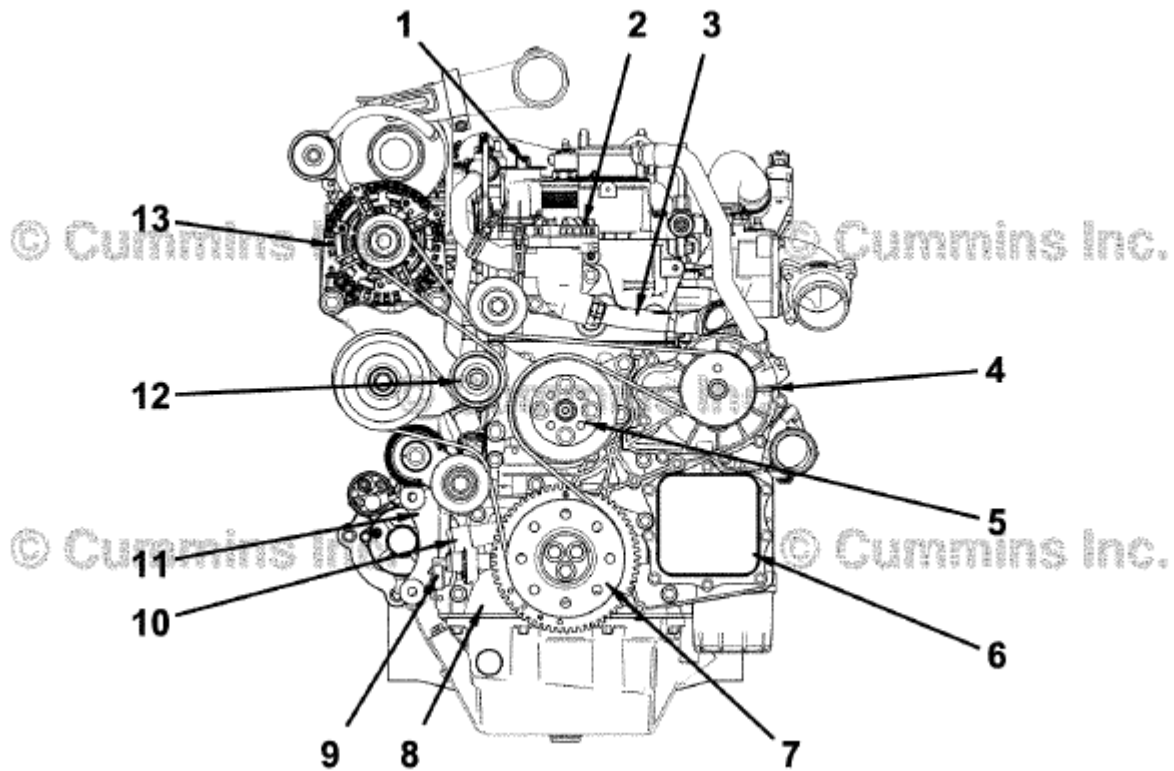

Front View

- 1 Lubricating oil fill
- 2 Thermostat housing
- 3 Thermostat bypass tube
- 4 Water pump
- 5 Cooling fan pulley
- 6 Lubricating oil cooler
- 7 Crankshaft pulley
- 8 Front gear cover
- 9 Crankshaft position sensor
- 10 Lubricating oil pressure regulator
- 11 Air conditioner compressor mounting location
- 12 Idler pulley
- 13 Alternator.

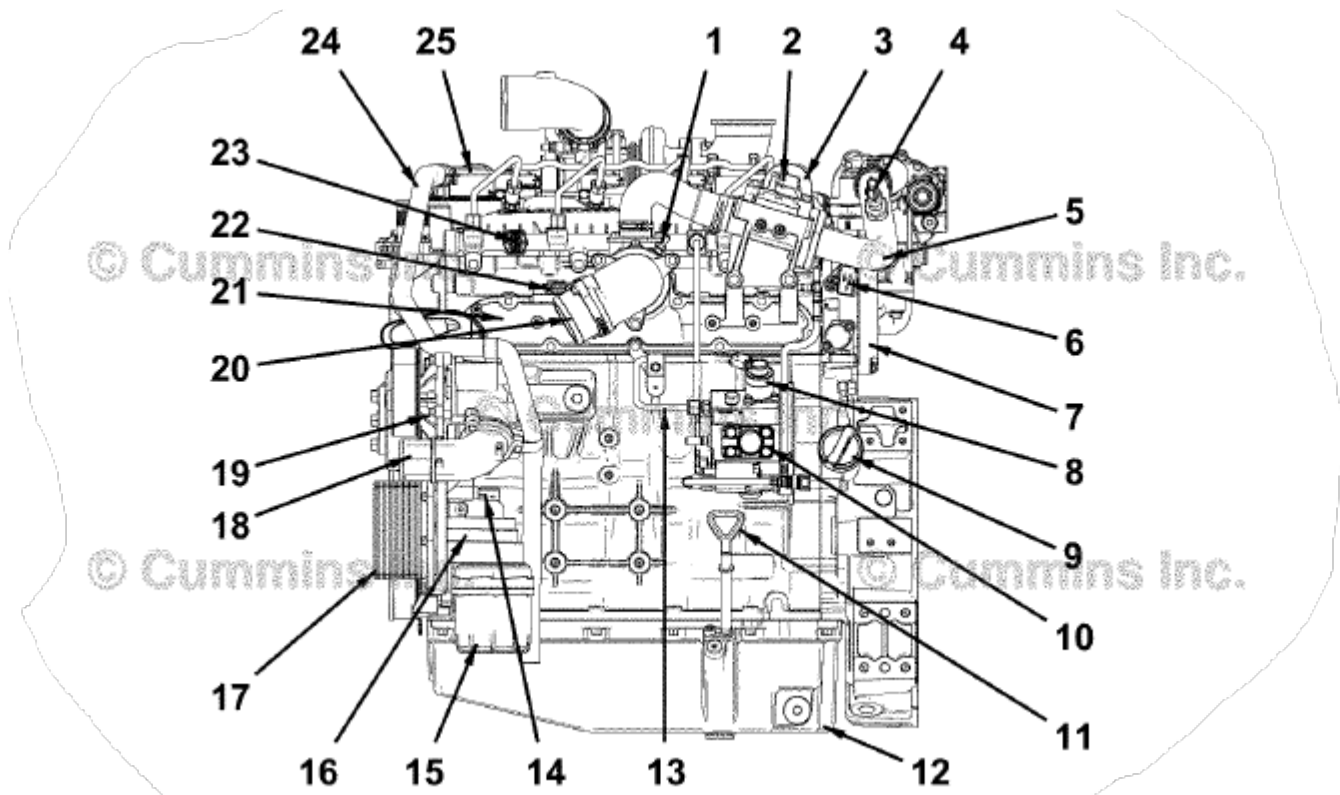

Left Side View

- 1 Intake air heater
- 2 Exhaust gas recirculation (EGR) differential pressure sensor adapter
- 3 Rear engine lifting bracket
- 4 EGR temperature sensor
- 5 EGR tube
- 6 Camshaft position sensor
- 7 Overhead camshaft sprocket housing
- 8 Fuel pump actuator
- 9 Lubricating oil fill
- 10 High-pressure fuel pump
- 11 Dipstick
- 12 Lubricating oil pan
- 13 Fuel rail supply line (high pressure)
- 14 Lubricating oil pressure sensor
- 15 Lubricating oil filter
- 16 Lubricating oil filter head
- 17 Lubricating oil cooler
- 18 Water pump inlet connection
- 19 Water pump
- 20 Intake air inlet connection
- 21 Intake air manifold
- 22 Intake manifold pressure/temperature sensor
- 23 Fuel rail pressure sensor
- 24 Crankcase breather tube
- 25 Crankcase breather

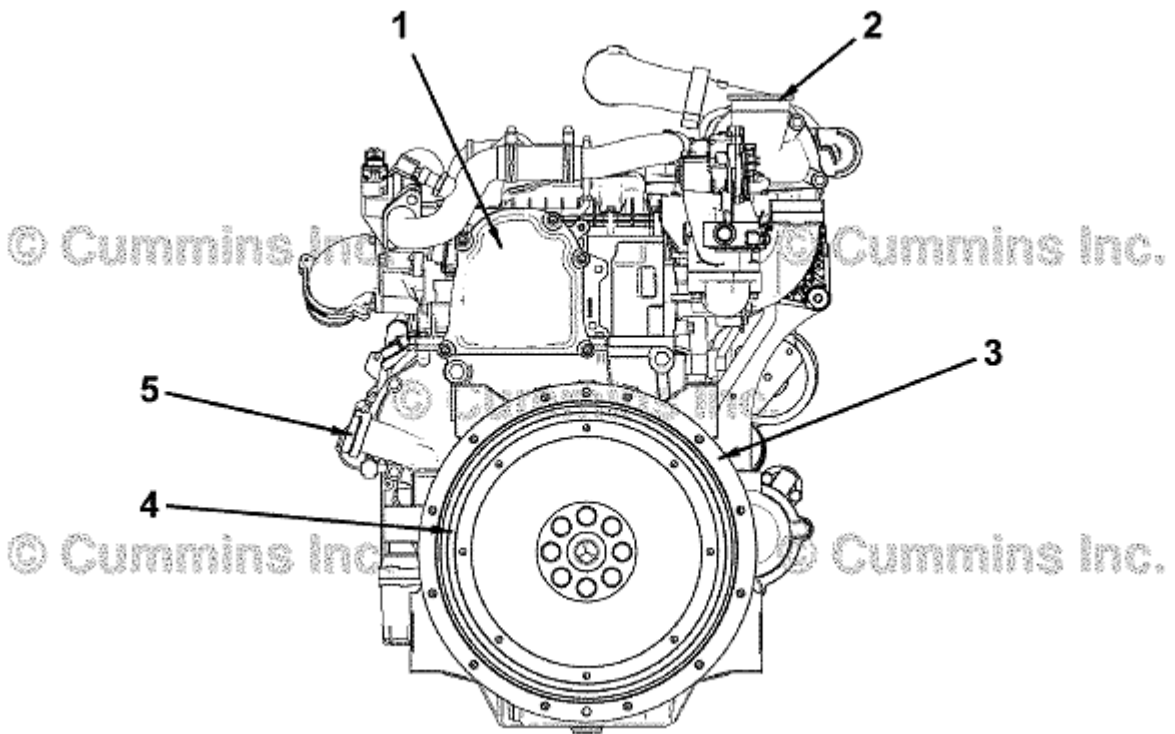

Rear View

- 1 Overhead camshaft sprocket housing cover
- 2 Turbocharger exhaust outlet
- 3 Flywheel housing
- 4 Flywheel
- 5 Lubricating oil fill.

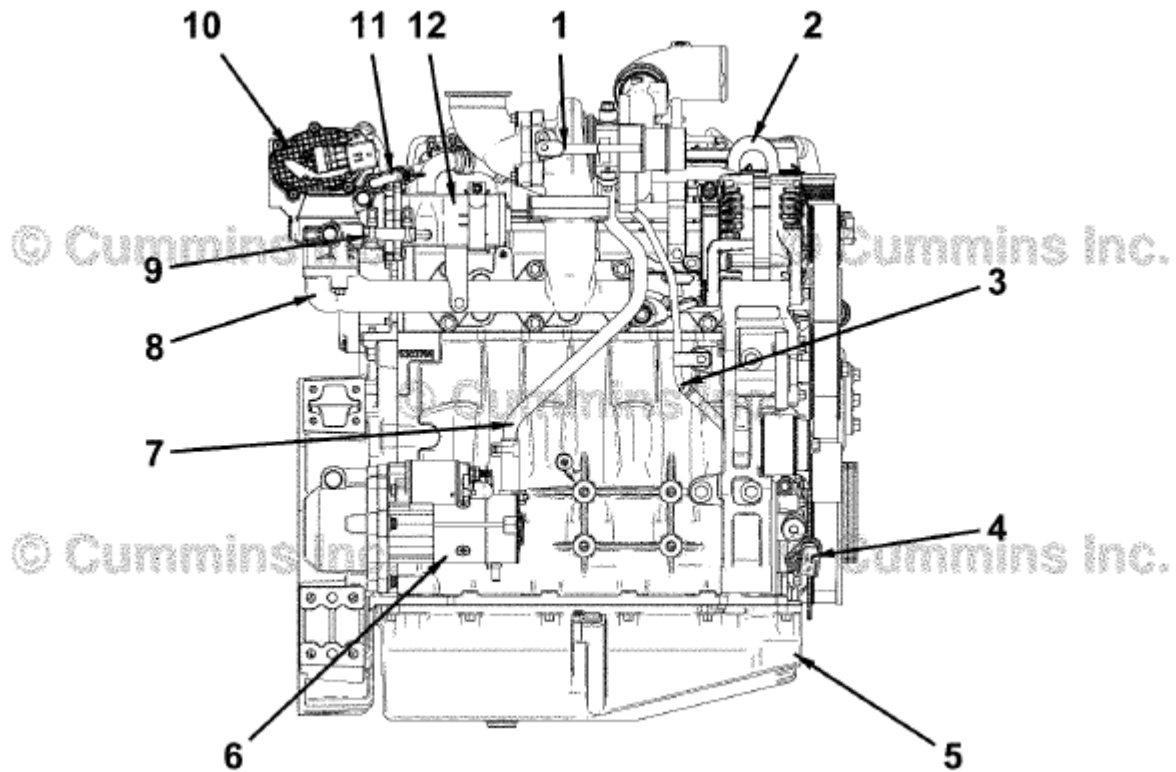

Right Side View

- 1 Turbocharger wastegate actuator
- 2 Front engine lifting bracket
- 3 Turbocharger oil supply line
- 4 Crankshaft position sensor
- 5 Lubricating oil pan
- 6 Starting motor
- 7 Turbocharger oil drain tube
- 8 Exhaust manifold
- 9 EGR valve coolant return line
- 10 EGR valve
- 11 EGR valve coolant supply line
- 12 EGR cooler

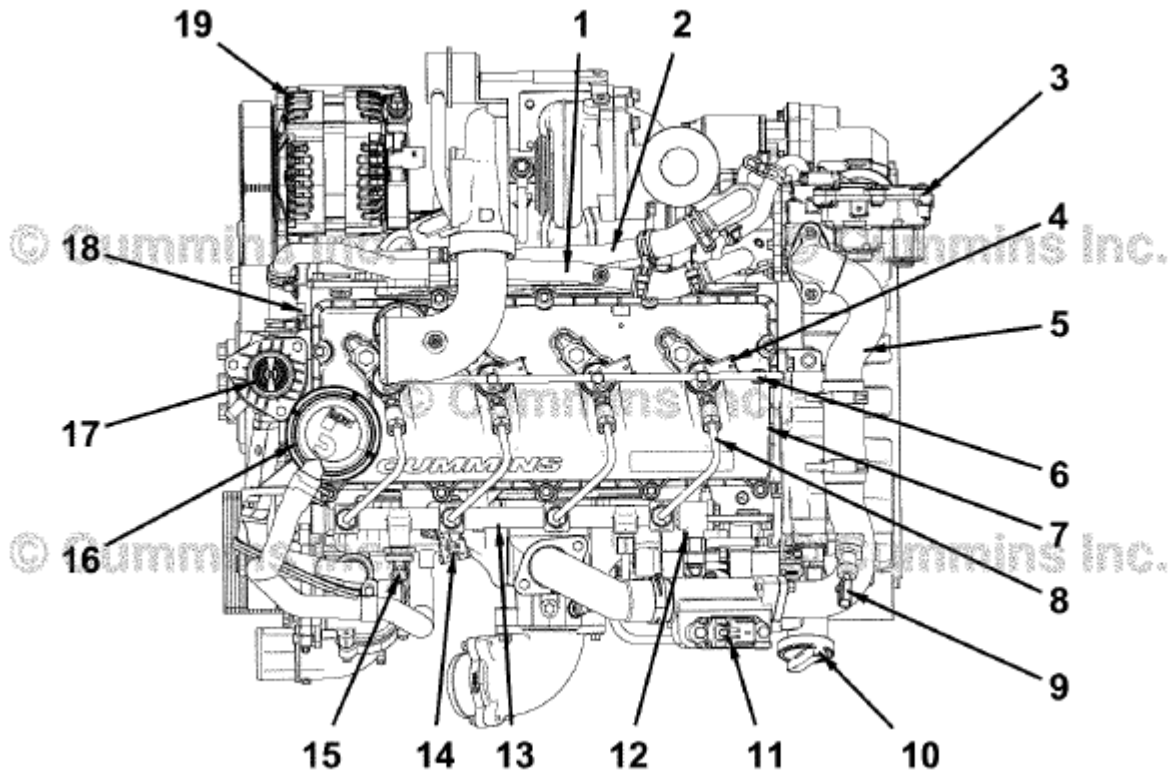

Top View

- 1 EGR cooler coolant return line
- 2 EGR cooler coolant supply line
- 3 EGR valve
- 4 Fuel injector
- 5 EGR crossover tube
- 6 Injector fuel return line
- 7 Valve cover
- 8 High pressure fuel injector supply line
- 9 EGR temperature sensor
- 10 Lubricating oil fill
- 11 EGR differential pressure sensor adapter
- 12 Fuel pressure relief valve
- 13 Fuel rail
- 14 Intake manifold pressure/temperature
- 15 Fuel rail pressure sensor
- 16 Crankcase breather
- 17 Thermostat
- 18 Coolant temperature sensor
- 19 Alternator