

MMG55DF4 | 2.9 L | 55kVA

MOBILE DIESEL GENERATOR SET

EPA Emissions Certification: Tier 4 Final

GENERAC® | MOBILE

Standby Power Rating

48 kW, 60 kVA, 60 Hz

Prime Power Rating

44 kW, 55 kVA, 60 Hz



*Assembled in the USA using domestic and foreign parts



Image used for illustration purposes only

Codes and Standards

Generac Mobile products are designed to the following standards:



CSA



NATM



TIER 4 FINAL EMISSIONS

Power When and Where You Need It

Generac Mobile diesel generators are designed and engineered to power a variety of projects, in the most extreme environments. Gensets are configured to meet customer needs, including choice of containment, cold weather packages, trailer options, and more.

Generac Mobile diesel generators are manufactured to deliver reliable power, when and where you need it.

STANDARD FEATURES

ENGINE SYSTEM

- John Deere® 3029HFG03
- 3 Cylinder
- Turbocharged & Aftercooled
- 177 in³ (2.9 L) Displacement
- EPA Tier 4 Final
- Power @ 1,800 rpm – hp (kW):
 - Prime: 67 (50)
 - Standby: 74 (55)
- Approved for use with Hydrotreated Vegetable Oil (HVO) fuels compliant with ASTM D975 or EN 15940
- Two Paper Element Air Filters
- Electronic Isochronous Governing
- Fixed Speed Fan
- One Spin-on Cartridge Oil Filter
- Oil Drain Extension
- One Fuel Filter
- One 12 V, 720 CCA, Wet Cell Battery

COOLING SYSTEM

- Capable of Operating at 120 °F (49 °C) Ambient
- 50/50 Coolant (50% Ethylene Glycol)
- Coolant Drain Extension

FUEL SYSTEM

- Polyethylene Fuel Tank
- Fuel Tank Capacity – gal (L):
 - Total: 100 (379)
 - Usable: 90 (341)
- Runtime @ 75% load: 28 hr

- 110% Containment - engine fluid (oil & coolant) and fuel
- Padlockable Fuel Cap

CONTROL SYSTEM

- Deep Sea Electronics 7310 MKII Controller
- 3-Position Voltage Selection Switch
- 225 A Main Circuit Breaker (MCB), Manual, with Shunt Trip
- Individual Convenience Receptacle Circuit Breakers
- Emergency Stop Switch
- Battery Disconnect Switch, Padlockable
- 2-Wire Remote Start/Stop Contacts

ALTERNATOR SYSTEM

- 60 Hz Engine-Driven Alternator
- SUPERSTART® Alternator
 - Brushless
 - 4 Pole
 - 2/3 Pitch
 - Class H Insulation
 - Corrosion Protection
- Marathon Electric PM500 AVR
- Shunt Excitation System

POWER DISTRIBUTION

- Connection Lugs
- Convenience Receptacles
 - Two 120 V, 20 A, GFCI Duplex (NEMA 5-20R)
 - Three 120/240 V, 50 A, 3 Pole, 4 Wire Twistlock (CS6369)

ENCLOSURE

- Aluminum, Sound Attenuated, Insulated and Baffled
- UV and Fade Resistant, High Temperature Cured, White Polyester Powder Paint
- Multi Lingual Operating and Safety Decals
- Fully Lockable Enclosure
- Central Lifting Point
- Document Holder with Owner's Manual—includes AC and DC Wiring Diagrams
- Control Panel Lights
- Interior Lights

TRAILER

- Hydraulic Surge Brakes
- 2 in. (50.8 mm) Ball Hitch
- Single 6,000 lb. (2,722 kg) Axle
- 15 in. Tire, 6 Ply, Tubeless
- 2,000 lb. (907 kg) Tongue Jack with Footplate
- Safety Chains with Spring Loaded Safety Hooks
- Transportation Tie Downs
- Plug Adapter, Round 7 Blade (SAE J2863)
- DOT Approved Tail, Side, Brake, and Directional Lights

WARRANTY

- 2 Year Limited or 2,000 Hours
 - Unlimited Hours Covered in First Year

CONTROL SYSTEM

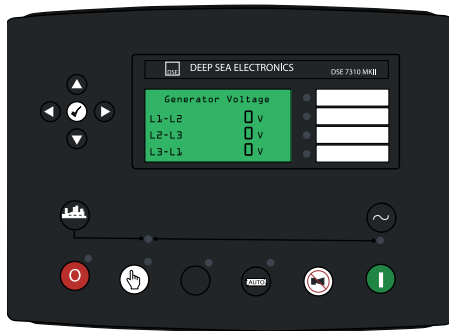

010643

Deep Sea Electronics CONTROLLER AND DISPLAY

- Model DSE7310 MKII
- 4 Line Back Lit LCD Text Display
- -40 to 158 °F (-40 to 70 °C) Operating Temperature Range
- Multiple Language Options
- Configurable Timers and Alarms
- Configurable Start/Stop Timers
- Configurable Maintenance Alarms
- Heated Display

PUSH BUTTONS FOR EASY OPERATION

- Manual or Auto Start
- Engine Start
- Engine Stop/Reset
- User Friendly Setup and Button Layout
- Five Key Menu Navigation
- Hours Counter
- Multiple Parameters are Monitored and Displayed Simultaneously for Full Visibility
- View Controller Parameters (Configuration, Firmware Version, Connections)

LCD ALARM INDICATION

- Generator Diagnostic Display
 - System kVA Output Display
 - Line Output and Frequency Display
- Alarm Types: Warning, Shutdown, Electrical Trip, Engine
- Alarm List – Warnings/Shutdowns; 250 Event History Log – Date/Time Stamped
 - Fuel Level: Warning – 15%; Shutdown – 5%
 - Overspeed Protection: Shutdown – 110%
 - Engine Diagnostic Warnings Communicated Through J1939 CANbus
 - Battery Voltage: Over – 15 VDC; Under – 11 VDC

- Generator Over Voltage: Warning – 110%; Electrical Trip – 115%
- Generator Under Voltage: Warning – 90%; Shutdown – 85%
- Generator Over Frequency: Warning – 105%; Electrical Trip – 110%
- Generator Under Frequency: Warning – 95%; Electrical Trip – 90%
- Auto Schedule
- Status

ELECTRICAL CONTROLS

- Lockable Control Box Door with Diagnostics Window
- Lockable Lug Box with Safety Switch
 - Trips Main Breaker When Door is Opened
 - Disables Voltage Regulator
- Output Ground Connection Lug Inside Lug Box

MMG55DF4 | 2.9 L | 55kVA

MOBILE DIESEL GENERATOR SET

EPA Emissions Certification: Tier 4 Final



CONFIGURABLE OPTIONS*

ENGINE SYSTEM

- Positive Air Shutdown (PAS), Electronic
- One 12 V, 720 CCA, AGM Optima Battery
- Oil Evacuation System - requires customer-sourced, specialized equipment to use for oil change

COLD WEATHER

- Engine Block Heater
- One Fuel Filter Heater
- 10 A Battery Charger
- 60/40 Coolant (60% Ethylene Glycol)

FUEL SYSTEM

- Steel Fuel Tank, Extended Runtime
- Fuel Tank Capacity - US gal (L):
 - Total: 160 (606)
 - Usable: 144 (545)

- Runtime @ 75% load: 45 hr
- Auxiliary Fuel Tank Connection
 - 3-Way Fuel Valve

CONTROL SYSTEM

- 4-Position Voltage Selection Switch
- Telemetry
- Lojack Equipment Recovery System

ALTERNATOR SYSTEM

- VFLEX (600 V) Alternator
- Permanent Magnet Generator (PMG) Excitation System

POWER DISTRIBUTION

- Camlocks—one set, female (US or Canada color code)
- Buck Transformer

ENCLOSURE

- Fire Extinguisher

TRAILER

- Skid Mount (Non-Trailer)
- Electric Brakes
- Tandem Axle
- 2 in. (50.8 mm) BULLDOG® Hitch
- 2-5/16 in. (58.7 mm) BULLDOG Hitch
- 3 in. (76.2 mm) Pintle Ring Hitch
- Rear Stabilizer Jacks

RATING DEFINITIONS

Standby: Applicable to varying emergency load for the duration of a utility power outage.

Prime: Applicable to supplying power to a varying load in lieu of utility for an unlimited amount of running time.

*Consult factory for availability.



MMG55DF4 | 2.9 L | 55 kVA

MOBILE DIESEL GENERATOR SET

EPA Emissions Certification: Tier 4 Final



APPLICATION AND ENGINEERING DATA

ENGINE SPECIFICATIONS

General

Make (Model)	John Deere (3029HFG03)
EPA Emissions Compliance	Tier 4 Final
After Treatment System	DOC and DPF
Cylinders – Qty	3
Type	In-Line
Displacement – in ³ (L)	177 (2.9)
Bore – in (cm)	4.2 (10.7)
Stroke – in (cm)	4.3 (11.0)
Compression Ratio	16.9:1
Intake Air Method	Turbocharged & Aftercooled

Engine Governing

Governor	Electronic
Frequency Regulation (Steady State)	±2%

Lubrication System

Oil Pump Type	Gear Driven
Oil Filter Type	Spin-On Cartridge, Full Flow
Crankcase Capacity – qt (L)	11 (10.4)

Cooling System

Cooling System Type	Radiator and CAC
Water Pump Type	Belt Driven
Fan Type	Pusher
Fan Speed – rpm	2,268
Fan Diameter – in (cm)	11.42 (29.0)
Cooling System Capacity – qt (L)	18 (17)

Fuel System

Fuel Type	Ultra Low Sulfur Diesel
Fuel Specifications	EN 590 / ASTM D975
Fuel Filtering – μ	5
Fuel Inject Pump – Make (Model)	Denso (HP3)
Fuel Pump Type	Engine Gear Driven
Injector Type	Electronic
Engine Type	Direct Injection High Pressure Common Rail
Fuel Supply Line Diameter – in (mm)	0.375 (9.5)
Fuel Return Line Diameter – in (mm)	0.375 (9.5)

Engine Electrical System

System Voltage – VDC	12
Battery Charger Alternator – VDC (A)	12 (65)
Battery Size – CCA	720
Battery Quantity	1
Ground Polarity	Negative (-)

SUPERSTART ALTERNATOR SPECIFICATIONS

Make (Model)	Marathon Electric (286PSL1701)
Poles – Qty	4
Field Type	Rotating
Insulation Class – Rotor	H
Insulation Class – Stator	H
Total Harmonic Distortion	<5%
Telephone Interference Factor	<50

Standard Excitation	Shunt
Bearings	Single Bearing
Coupling	Direct Flexible Disc
Prototype Short Circuit Test	Yes
Voltage Regulator Type	AVR
Number of Sensed Phases	All
Regulation Accuracy (Steady State)	±0.5%

VFLEX ALTERNATOR SPECIFICATIONS

Make (Model)	Marathon Electric (286PSL1701)
Poles – Qty	4
Field Type	Rotating
Insulation Class – Rotor	H
Insulation Class – Stator	H
Total Harmonic Distortion	<5%
Telephone Interference Factor	<50

Standard Excitation	Shunt
Bearings	Single Bearing
Coupling	Direct Flexible Disc
Prototype Short Circuit Test	Yes
Voltage Regulator Type	AVR
Quantity of Sensed Phases	All
Regulation Accuracy (Steady State)	±0.5%

MMG55DF4 | 2.9 L | 55kVA

MOBILE DIESEL GENERATOR SET

EPA Emissions Certification: Tier 4 Final



OPERATING DATA

POWER RATINGS

	SUPERSTART Alternator		VFLEX Alternator	
	Standby: kW/kVA (A)	Prime: kW/kVA (A)	Standby: kW/kVA (A)	Prime: kW/kVA (A)
1-Phase, 120/240 VAC @ 1.0 pf—zig zag*	46/46 (192)	42/42 (175)	19/19 (79)	19/19 (79)
3-Phase, 208/120 VAC @ 0.8 pf—low wye	48/60 (167)	44/55 (153)	39/49 (135)	35/44 (121)
3-Phase, 240/120 VAC @ 0.8 pf—delta**	48/60 (144)	45/55 (132)	39/49 (117)	35/44 (105)
3-Phase, 480/277 VAC @ 0.8 pf—high wye	48/60 (72)	45/55 (66)	39/49 (59)	35/44 (53)
3-Phase, 600/346 VAC @ 0.8 pf—high wye	N/A	N/A	48/60 (58)	44/55 (53)

*Alternator limited.

**Power ratings achieved through use of optional 4-position voltage selection switch.

FUEL CONSUMPTION RATES

Prime Load	Fuel: gph (L/hr)
50%	2.3 (8.7)
75%	3.2 (12.1)
100%	3.9 (14.8)
110% (Standby)	4.2 (30.2)

Deration – Operational characteristics consider maximum ambient conditions. Derate factors may apply under atypical site conditions.

Please contact a Generac Mobile Authorized Service Dealer for additional details. All performance ratings in accordance with ISO3046, BS5514, ISO8528, ISO8665, ISO3046, SAE J1228, SAE J1995, and DIN6271 standards.

MMG55DF4 | 2.9 L | 55 kVA

MOBILE DIESEL GENERATOR SET

EPA Emissions Certification: Tier 4 Final



DIMENSIONS AND WEIGHTS*

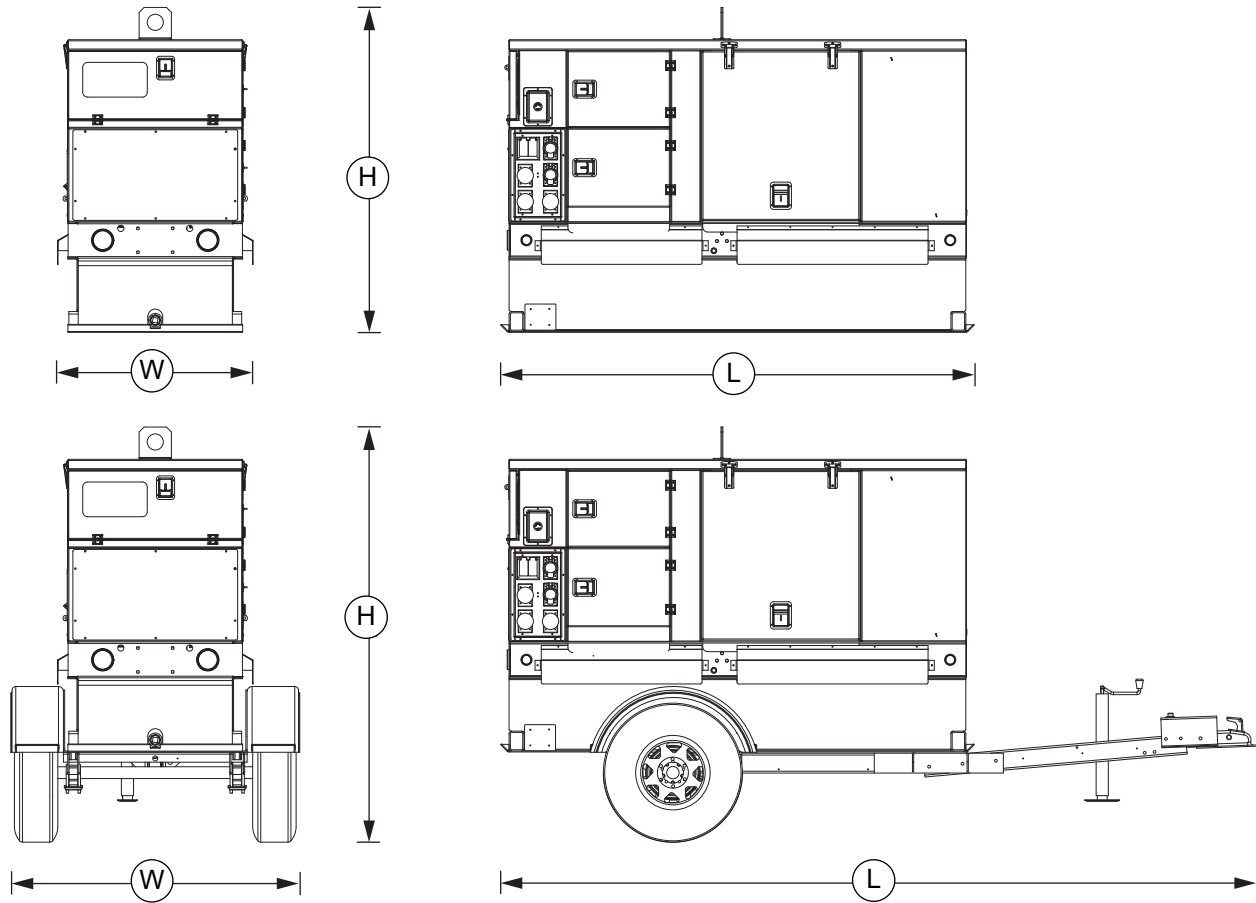

01906

	Run Time: hr*	Usable Fuel Capacity: gal (L)	Dimensions – L×W×H: in (m)	Weight: lb (kg)
Skid	28	90 (341)	95 (2.41)×39 (.99)×65 (1.65)	Dry: 3,305 (1,499)
				Operating: 4,040 (1,833)
Trailer	28	90 (341)	152 (3.81)×58 (1.45)×83 (2.11)	Dry: 3,905 (1,771)
				Operating: 4,640 (2,105)

* Runtime based on 75% prime rated power.

SOUND RATING

- 68 dB(A) @ 23 ft (7 m) @ Prime Power

* All measurements are approximate and for estimation purposes only.

YOUR FACTORY RECOGNIZED GENERAC MOBILE DEALER

Specification characteristics may change without notice. Dimensions and weights are for preliminary purposes only. Please contact a Generac Mobile Products Authorized Service Dealer for detailed installation drawings.