

MLG20IF4 | 2.2 L | 20 kVA

MOBILE DIESEL GENERATOR SET

EPA Emissions Certification: Tier IV Final



Standby Power Rating

20 kW, 20 kVA, 60 Hz

Prime Power Rating

19 kW, 19 kVA, 60 Hz



Image used for illustration purposes only

Codes and Standards

Generac Mobile products are designed to the following standards:



CSA



NATM



TIER 4 FINAL EMISSIONS



ISO 8528-5

Power When and Where You Need It

Generac Mobile diesel generators are designed and engineered to power a variety of projects, in the most extreme environments. Gensets are configured to meet customer needs, including choice of containment, cold weather packages, trailer options, and more.

Generac Mobile diesel generators are manufactured to deliver reliable power, when and where you need it.

MLG20IF4 | 2.2 L | 20 kVA

MOBILE DIESEL GENERATOR SET

EPA Emissions Certification: Tier IV Final



STANDARD FEATURES

ENGINE SYSTEM

- Isolated Mounted Engine Supports
- Paper Element Air Filter with Safety Cartridge
- Fixed Speed Fan Drive
- Spin on Cartridge Oil Filter
- 720 CCA Wet Cell Battery

COOLING SYSTEM

- Capable of Operating at 120 °F (49 °C) Ambient
- Oil Filter: Spin-On Cartridge, Full Flow
- 50/50 Coolant (Ethylene Glycol)
- Factory Installed Radiator
- UV/Ozone Resistant Hoses
- Closed Coolant Recovery System

FUEL SYSTEM

- Fuel Tank Capacity – gal (L):
 - Total 43.7 (165.4)
 - Usable: 39.4 (149.2)
- Primary Fuel Filter
- Pressure Tested Fuel Tank
- Fuel Level Gauge

CONTROL SYSTEM

- Power Zone® digital controller
- 100 A Start Limit Breaker – Ensures No Load Condition Exists Before Starting
- Engraved Aluminum Punched and Anodized Control Panel
- Hour meter
- Automatic Shutdown for High Coolant Temperature and Low Oil Pressure

GENERATOR SYSTEM

- Brushless Excitation
- 2/3 Pitch
- Four Pole
- Class F insulation
- Sealed Bearing

POWER DISTRIBUTION

- Convenience Receptacles with Individual Breakers
 - (2) 120 V, 20 A, GFCI Duplex (NEMA 5-20R)
 - (2) 240 V, 30 A, Twistlock (NEMA L6-30R)
 - (2) 120//240 V, 50 A, Twistlock (CS6369)

ENCLOSURE

- Steel, 14-Gauge, Sound Attenuated Enclosure
- White Polyester Powder Paint
 - UV and Fade Resistant
 - High Temperature Cured
- Fully Lockable Enclosure
- Stainless Steel Hinges, Door Latches, and Exterior Hardware
- Exterior Emergency Stop Switch
- Multi-lingual Operating/Safety Decals
- Document Holder with Operating Manual, Including AC and DC Wiring Diagrams

TRAILER

- DOT Approved Tail, Side, Brake, and Directional Lights; Recessed Rear Lights
- Illuminated License Plate
- Transportation Tie Downs
- Safety Chains with Spring Loaded Safety Hooks
- 2 in. (50.8 mm) Ball Hitch
- Single Axle—2,200 lb (990 kg) Leaf Spring
- 2,000 lb (907 kg) Tongue Jack with Footplate
- 13 in. (330 mm) Tires
- ST175/80D13 Tubeless Tires—6 Ply

WARRANTY

- 2 years, 2,000 Hours
- Unlimited Hours Covered in First Year

CONFIGURABLE OPTIONS**ENGINE SYSTEM**

- Positive Air Shutoff (Electronic)
- 720 A CCA Wet Cell Battery

COLD WEATHER

- 10 A Battery Charger
- Lower Radiator Hose Heater
- CCV Heater
- Fuel Filter Heater
- 60/40 Coolant (60% Ethylene Glycol)

FUEL SYSTEM

- Fuel & Engine Fluid Containment

CONTROL SYSTEM

- Lockable Battery Disconnect
- LoJack Equipment Recovery System

POWER DISTRIBUTION

- Package 1:
 - (2) 120 V, 20 A, GFCI Duplex (NEMA 5-20R)
 - (3) 240 V, 30 A, Twistlock (NEMA L6-30R)
 - (1) 120/240 V, 50 A, Twistlock (CS6369)
- Package 2:
 - (2) 120 V, 20 A, GFCI Duplex (NEMA 5-20R)
 - (3) 240 V, 30 A, Twistlock (NEMA L14-30R)
 - (1) 120/240 V, 50 A, Twistlock (CS6369)
- Package 3:
 - (2) 120 V, 20 A, GFCI Duplex (NEMA 5-20R)
 - (4) 240 V, 30 A, Twistlock (NEMA L14-30R)
- Package 4:
 - (2) 120 V, 20 A, GFCI Duplex (NEMA 5-20R)
 - (3) 240 V, 20 A, Twistlock (NEMA L6-20R)
 - (1) 120/240 V, 50 A, Twistlock (CS6369)
- Package 5:
 - (2) 120 V, 20 A, GFCI Duplex (NEMA 5-20R)
 - (1) 120 V, 30 A, RV (NEMA TT-30R)
 - (1) 240 V, 30 A, Twistlock (NEMA L6-30R)
- Package 6:
 - (2) 120 V, 20 A, GFCI Duplex (NEMA 5-20R)
 - (2) 120 V, 30 A, RV (NEMA TT-30R)
 - (2) 120/240 V, 30 A (NEMA 14-50R)

ENCLOSURE

- Central Lift Point
- 5 lb Fire Extinguisher

TRAILER

- Hitches:
 - Combination 2 in. Ball/2½ in. Pintle Ring Adjustable
 - 3 in. Pintle Ring
 - 2 in. Ball BULLDOG®
- Spare Tire and Carrier
- Plug Adapter—Flat 4 to Round 7 Spade
- Rear Stabilizer Jacks
- Toolbox: Black Polymer or Aluminum, 49×15×18.5 in. (125×38×47 cm)

RATING DEFINITIONS

Standby - Applicable for varying emergency load for the duration of a utility power outage.

Prime - Applicable for supplying power to a varying load in lieu of utility for an unlimited amount of running time.

MLG20IF4 | 2.2 L | 20 kVA

MOBILE DIESEL GENERATOR SET

EPA Emissions Certification: Tier IV Final



APPLICATION AND ENGINEERING DATA

ENGINE SPECIFICATIONS

General

Make	Isuzu 4LE2TAG
EPA Emissions Compliance	Tier IV Final
Cylinder #	4
Type	Inline
Displacement	133 in ³ (2.2L)
Bore – in (mm)	3.35 (85)
Stroke – in (mm)	3.78 (96)
Compression Ratio	TBD
Intake Air Method	Turbocharged

Engine Governing

Governor	Electric
Frequency Regulation (Steady State)	5%

Lubrication System

Oil Pump Type	Gear
Oil Filter Type	Spin On
Crankcase Capacity – qts (L)	8.0 (7.6)

Cooling System

Cooling System Type	Water Jacket
Water Pump Type	Belt Driven
Fan Type	Blower
Fan Speed (rpm)	1,800
Fan Diameter – in (mm)	20.0 (508)
Cooling System Capacity – qt (L)	12.0 (11.3)

Fuel System

Fuel Type	Ultra-Low Sulfur Diesel
Fuel Specifications	ASTM Diesel Fuel Oil No. 2 (JIS K2204 Gas Oil Specification No. 2 or 3)
Fuel Pump Type	Gear
Injector Type	Direct
Fuel Supply Line – in (mm)	0.313 (7.9)
Fuel Return Line – in (mm)	0.313 (7.9)

Engine Electrical System

System Voltage	12 VDC
Battery Charger Alternator	60 A
Battery Size	720 CCA
Ground Polarity	Negative

ALTERNATOR SPECIFICATIONS

Standard Model	Marathon Electric 334CSA3028
Poles	4
Field Type	Rotating
Insulation Class - Rotor	F
Insulation Class - Stator	F
Total Harmonic Distortion	<5%
Standard Excitation	Brushless

Bearings	Single Bearing, Double Shielded
Coupling	Direct Via Flex Plate
Prototype Short Circuit Test	Yes
Voltage Regulator Type	AVR
Number of Sensed Phases	1
Regulation Accuracy (Steady State)	± 1%

MLG20IF4 | 2.2 L | 20 kVA

MOBILE DIESEL GENERATOR SET

EPA Emissions Certification: Tier IV Final



OPERATING DATA

POWER RATINGS

	Standby kW/kVA	Amps	Prime kW/kVA	Amps
Single-phase, 120/240 VAC@1.0pf	20/20	83	19/19	79

FUEL CONSUMPTION RATES*

	gal/hr (L/hr) @ Prime
50%	1.05 (4.0)
75%	1.58 (6.0)
100%	2.1 (7.8)

Deration – Operational characteristics consider maximum ambient conditions. Derate factors may apply under atypical site conditions.

Please consult a Generac Mobile Authorized Service Dealer for additional details. All performance ratings in accordance with ISO3046, BS5514, ISO8528, ISO8665, ISO3046, SAE J1228, SAE J1995, and DIN6271 standards.

MLG20IF4 | 2.2 L | 20 kVA

MOBILE DIESEL GENERATOR SET

EPA Emissions Certification: Tier IV Final



DIMENSIONS AND WEIGHTS*

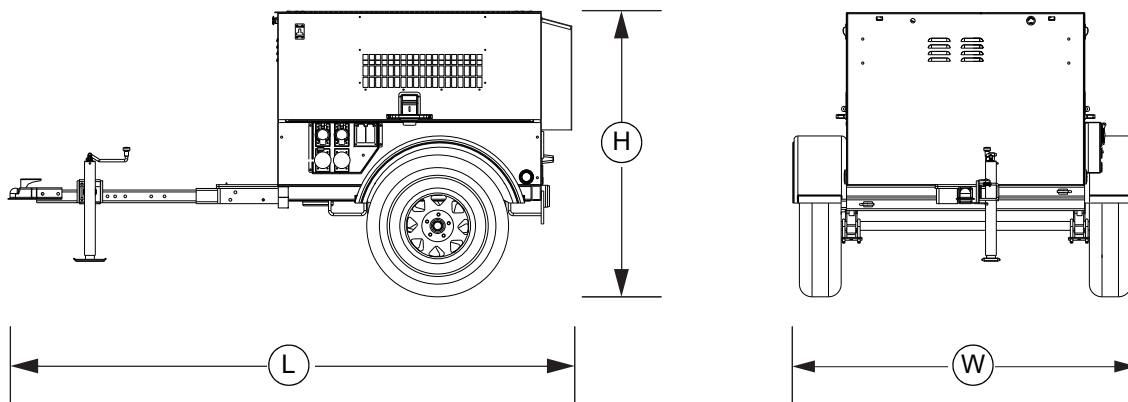

00847

Run Time: hr	Usable Fuel Capacity: Gal (L)	Dimensions – L×W×H: in (m)	Weight: lb (kg)
23.8	50 (189)	105×68×56 (2.67×1.73×1.42)	Dry: 1,471 (667) Operating: 1,831 (831)

SOUND RATING

- 70 dB(A) @ 23 ft (7 m) & full load

* All measurements are approximate and for estimation purposes only.

YOUR FACTORY RECOGNIZED GENERAC MOBILE PRODUCTS DEALER

Specification characteristics may change without notice. Dimensions and weights are for preliminary purposes only. Please consult a Generac Mobile Products Authorized Service Dealer for detailed installation drawings.