

SPECIFICATIONS

ENGINE SYSTEM

- Kubota® Z482
- Diesel fueled
- EPA Tier 4 Final
- 2 cylinder
- 0.479 L displacement
- Power @ 1,800 rpm: 5.1 hp (3.8 kW)
- Air filter: Dry type cartridge

Fuel System

- Tank usable capacity: 64.4 US gal (240 L)
- Fuel consumption – lights only: 0.214 US gph (0.8 L/hr.)
- Run time – lights only: 300 hr.

Cooling System

- Liquid cooled

Lubrication System

- Oil filter: Full flow, spin-on type

GENERATOR

- Alternator Rating: 4.2 kW, 120/240 V, 60 Hz
- System Output: 2 kW

CONTROLS

- Controller with timer activation
- Dusk to dawn
- Lights On/Off

TRANSPORT

- 18 units per 48' flatbed (dry)
- 16 units per 48' flatbed (with fuel)



Picture shown may not reflect actual configuration.

STATIONARY HYPERCUBE (SLT-D)

LIGHTS

- Four 320 W LED fixtures
 - 360° illumination
 - Lm/fixture: 46,000
 - Total lm: 184,000
- Coverage @ minimum 0.5 ft-c:
 - Standard (forward) configuration, 60° tilt: 19,441 ft² (1,806 m²)
 - 360° lights, 60° tilt: 33,496 ft² (3,112 m²)
 - 360° lights, 0° tilt: 4,304 ft² (400 m²)

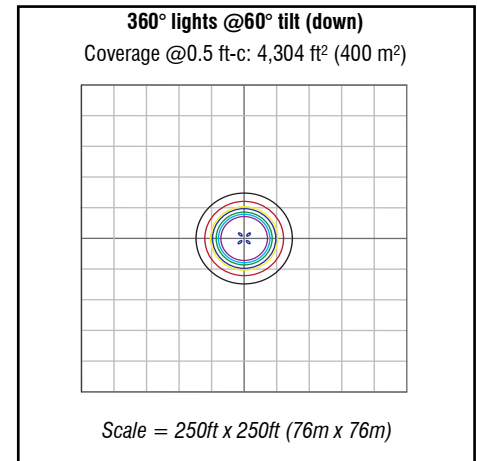
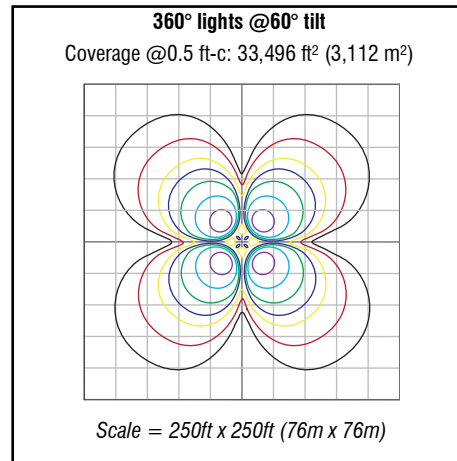
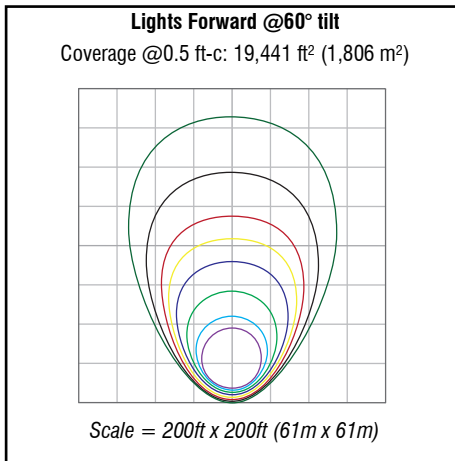

ELECTRICAL SYSTEM

- 1 inlet, 20 A, 240 V, L14-20P
- 1 outlet, 20 A, 240 V, L14-20R
- 2 outlet, 15 A, 120 V, GFCI 5-15R

MAST

- Galvanized construction with 6 sections
- Leveling “bubble” indicators to assist with setup
- 340° manual rotation with mast fully extended

ENCLOSURE

- 5 Lockable doors for ease of service and maintenance
- Galvanized base-frame-mast / Powder coated panels
- Multi-lingual operating and safety decals
- Document holder with owner’s manual
- Sound rating: 60 dB(A) @ 23 ft. (7 m)
- 110% fluid containment with drain plug
- Center lifting point
- Fork lift pockets on all 4 sides
- Extended fork pockets to protect enclosure during lifting
- LED Drivers mounted inside enclosure
- Step for easy access to adjust lights
- Access to power cable outlets when doors are locked

DIMENSIONS

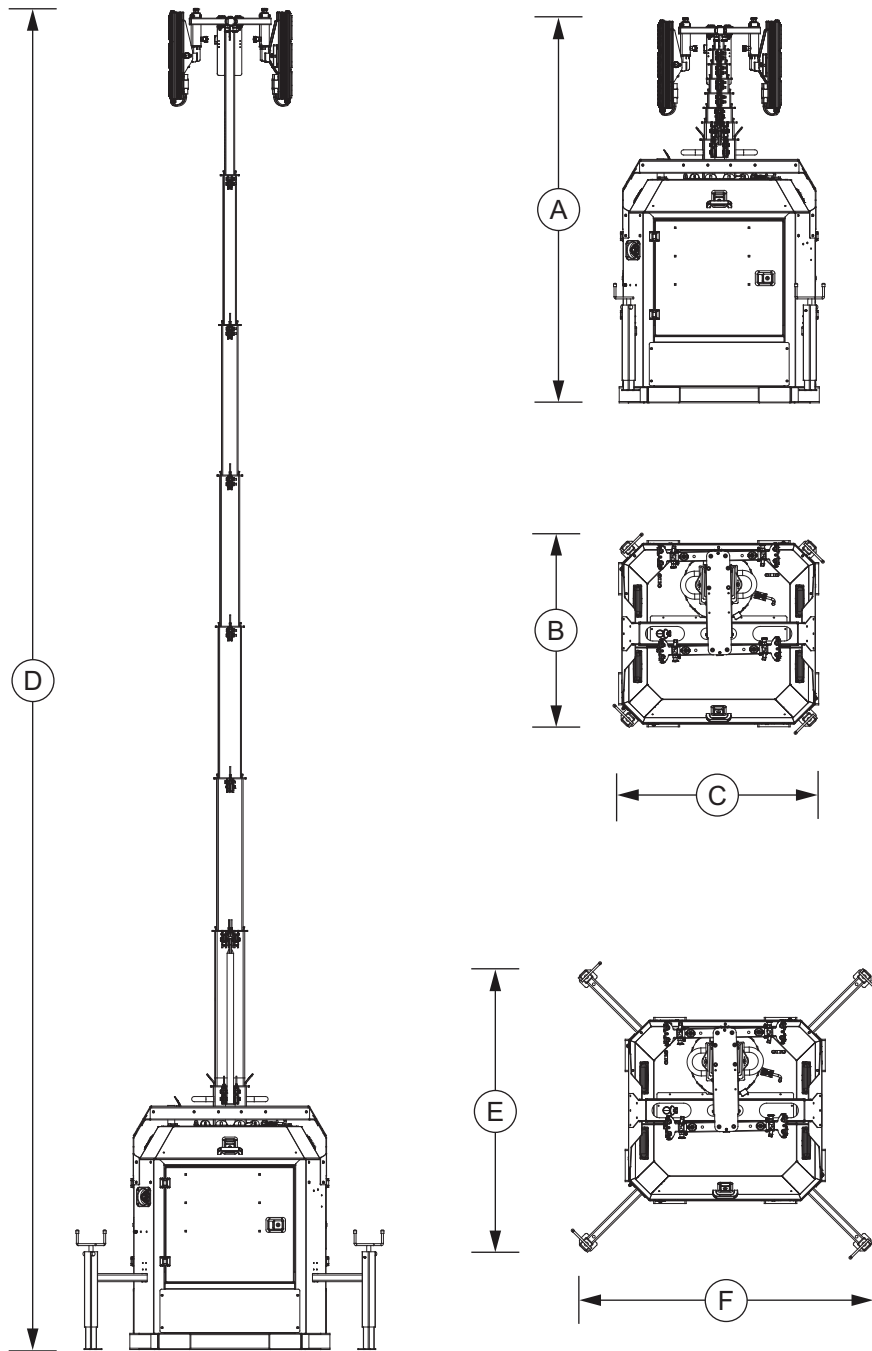

A	B	C	D	E	F
93.9 in (2.39 m)	48.5 in (1.23 m)	51.5 in (1.31 m)	27 ft (8.2 m)	68.3 in (1.74 m)	73.3 in (1.86 m)

WEIGHT

- Dry: 2,389 lb. (1,084 kg)
- Operating: 2,839 lb. (1,288 kg)

STATIONARY HYPERCUBE (SLT-D)

STANDARD MODELS

- Standard Generac configurations

	SLT-D CUBEHYPRK2 0°F (-18°C) Standard	SLT-D CUBEHYPRK2CW -20°F (-29°C) Cold Weather
Air intake heater	•	•
Coolant heater		•
60/40 coolant		•
Heated fuel filter		•
720 CCA battery		•

- Optional: Diffused LED kit – reduces glare and minimizes light pollution

AMBIENT CLIMATE RATINGS

- Wind rating: 68 mph (110 km/h)
- Maximum air temperature: 120°F (49°C)

CERTIFICATIONS

- CSA with cold-weather configuration

WARRANTY

- Tower: 1 year, unlimited hours/ 2 years, 2,000 hours
- LED modules and drivers: 5 year limited warranty

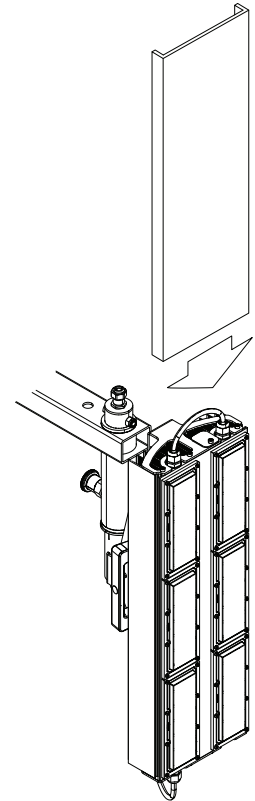

Diffused LED Kit: 4 diffusers slide onto light fixtures
Order Kit PN: A0000773887

* All measurements are approximate and for estimation purposes only.



Specification characteristics may change without notice. Dimensions and weights are for preliminary purposes only. Please consult a Generac Mobile Authorized Service Dealer for detailed installation drawings.