

CUBE™ | Stationary Light Tower

Long run time & quiet operation make this 360° light tower stand out.

LIGHTS

(4) 320W LED 360° adjustable illumination
184,000 total lumen
27' (8.2m) galvanized hydraulic mast
68MPH (110km/h) wind rating
Optional diffuser kit available
Hydraulic mast

POWER

Kubota® Z482 — 2 cylinder diesel engine
300 Hour run time (lights only)
Auto dusk to dawn controller
CSA included with cold weather model

ENCLOSURE

110% Fluid containment
60 dB(A) at 23' (7m)
Five lockable easy-access doors
Safe internal locking stabilizers
Center lift point and fork pockets
Galvanized base and frame
18 units on a 48' flatbed (16 fueled)

EXPORT POWER



OUTPUT

20A, 240V
NEMA L14-20R

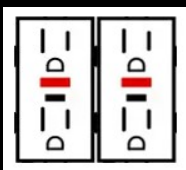

OUTPUT

(2)15A, 120V
GFCI 5-15R

- ✓ 300 Hour Runtime
- ✓ Quiet — 60 dB(A)
- ✓ 360° Light Coverage
- ✓ Full Containment

360° Adjustable Light Coverage



DIMENSIONS

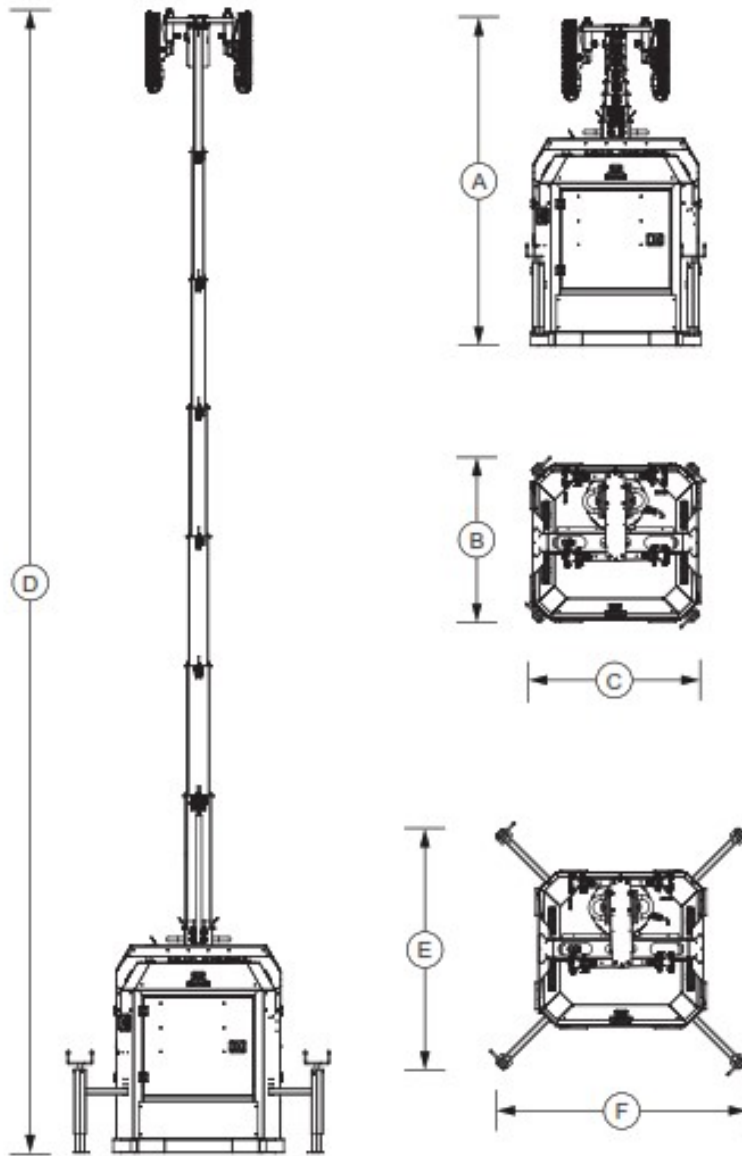

A	B	C	D	E	F
93.9 in (2.39 m)	48.5 in (1.23 m)	51.5 in (1.31 m)	27 ft (8.2 m)	68.3 in (1.74 m)	73.3 in (1.86 m)

WEIGHT

- Dry: 2,389 lb. (1,084 kg)
- Operating: 2,839 lb. (1,288 kg)

