

DETAIL A

LOAD CONNECTION BUS BAR  
TYP 3 PLACES (PH A, B & C)  
SCALE: NONE

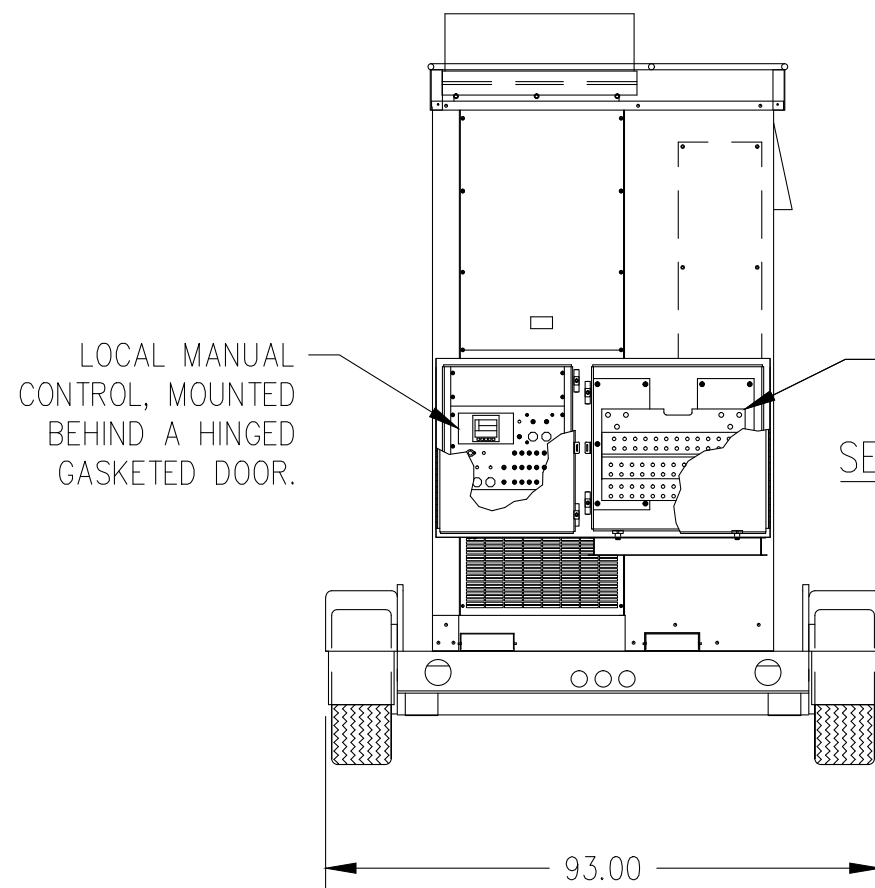

LOCAL MANUAL CONTROL, MOUNTED BEHIND A HINGED GASKETED DOOR.

LOAD CONNECTION BUS BARS

SEE DETAIL A

LOCAL CONTROL & LOAD CONNECTION ENCLOSURE  
CABLE ACCESS THROUGH BOTTOM OF ENCLOSURE

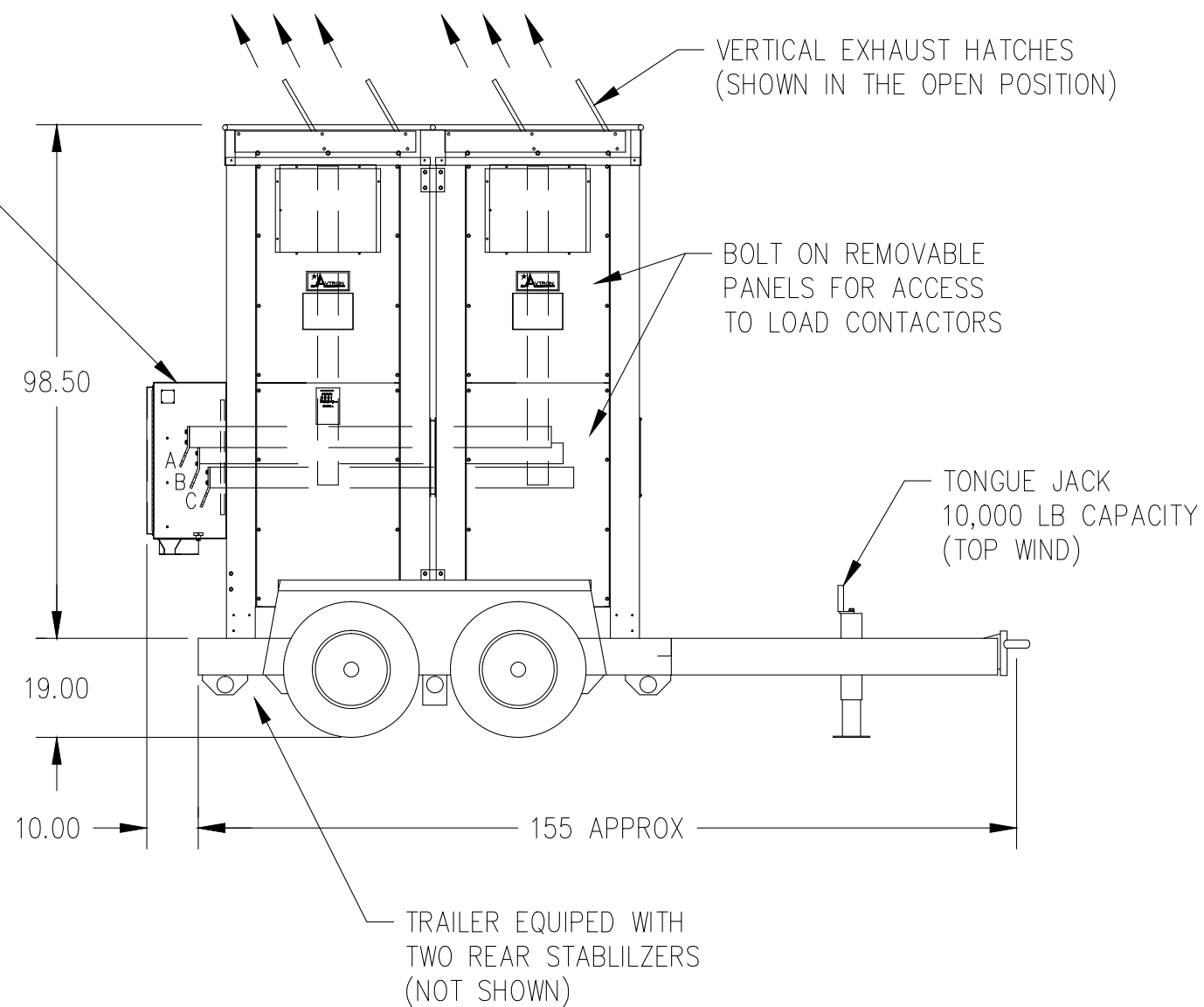
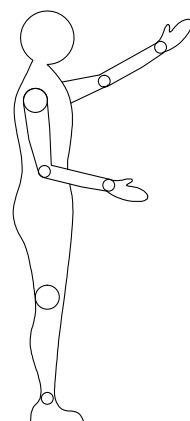

VERTICAL EXHAUST HATCHES (SHOWN IN THE OPEN POSITION)

BOLT ON REMOVABLE PANELS FOR ACCESS TO LOAD CONTACTORS

TONGUE JACK  
10,000 LB CAPACITY (TOP WIND)

TRAILER EQUIPED WITH TWO REAR STABILIZERS (NOT SHOWN)

- NOTES:
1. WEIGHT: 5,500 LBS. APPROX. AS SHOWN
  2. ALL DIMENSIONS ARE APPROX.
  3. ALL DIMENSIONS ARE IN INCHES.
  4. CABLE STORAGE REQUIRES TRAILER UPGRADE AND FRONT TONGUE MOUNTED EQUIPMENT.
  5. UNIT PROVIDED WITH TRAVEL AND STORAGE COVER (NOT SHOWN).



TRAILER MOUNT LOAD BANK  
GENERAL REFERENCE OUTLINE DRAWING

Model 5820

Rev A