

- NOTES:
7. A CRANE IS REQUIRED FOR HANDLING. DO NOT USE BASE OR SHIPPING BLOCKS/CHANNELS FOR LIFT. LIFT PRIOR TO INSTALLING EXHAUST HOODS.
 6. REVIEW MANUAL BEFORE HANDLING, INSTALLATION OR OPERATION.
 5. SEE SHEETS 2 & 3 FOR ADDITIONAL NOTES & DETAILS.
 4. ALL MEDIUM VOLTAGE ACCESS PANELS INCLUDE DOOR STOPS.
 3. VERTICAL EXHAUST THROUGH FIXED EXHAUST HOODS, EXHAUST HOODS SHIPPED SEPARATELY.
 2. ALL DIMENSIONS ARE APPROX. IN INCHES & [MM].
 1. WEIGHT: APPROX. 19,000 LBS [8618 KG]

BLOCK INDICATES TEMPORARY FULL WIDTH SHIPPING CHANNEL, DO NOT LIFT BY THIS CHANNEL DISCARD CHANNELS ONCE ON SITE. (TYPICAL BOTH SIDES) SEE SHEET 2



MEDIUM VOLTAGE LOAD BANK
GENERAL REFERENCE OUTLINE DRAWING

Model 9100

1 OF 4

Rev. -

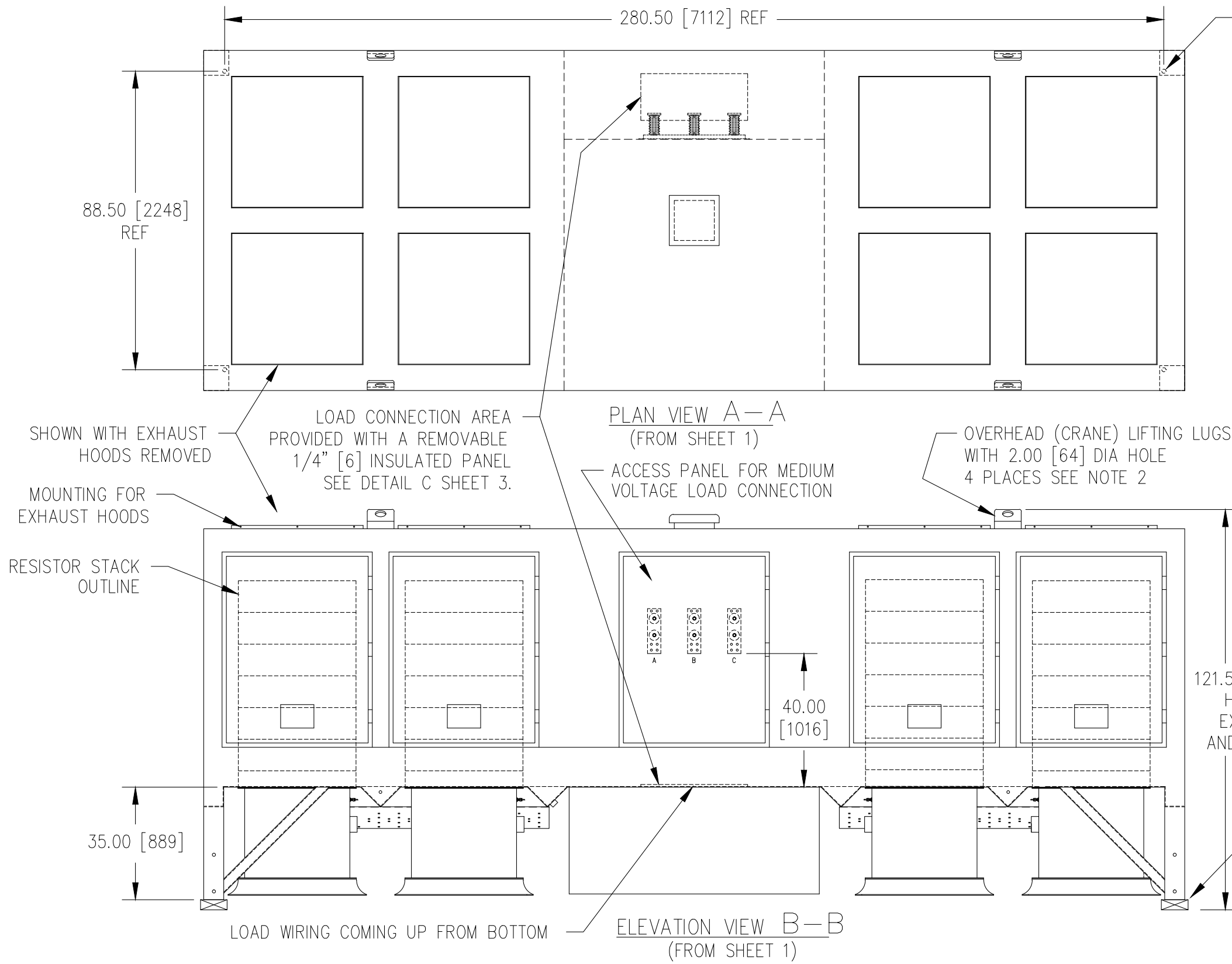

- LOAD BANK HANDLING/INSTALLATION NOTES:
- 1) LOAD BANK SHOWN AS SHIPPED ON THIS SHEET 2. SEE SHEET 1 FOR INSTALLATION OF EXHAUST HOODS & EXTENSION LEGS.
 - 2) FOR HANDLING, A CRANE IS REQUIRED LIFT LOAD BANK VIA FOUR FORMED ROOF MOUNTED CLEATS. DO NOT USE BASE OR SHIPPING CHANNELS FOR LIFT. LIFT PRIOR TO INSTALLING EXHAUST HOODS.
 - 3) LOAD BANK MUST BE RAISED 30" [762] MIN. ABOVE GRADE, USING SUPPLIED LEG EXTENSIONS, STRUTS AND FACTORY PROVIDED HARDWARE AS SHOWN ON SHEET 1.
 - 4) AS A GENERAL GUIDE, PROVIDE 72" [1800] CLEARANCES ON ALL SIDES. A MINIMUM OF 36" [900] MUST BE TO ANY SURFACE, DEVICE, COMPONENT.
 - 5) ANY OBSTRUCTION WITHIN 50' [1270] OF ANY INTAKE WILL INFLUENCE AIRFLOW. REVIEW MANUAL OR SUBMIT TO AVTRON FOR REVIEW.
 - 6) ON EXHAUST, MINIMUM 16' [5M] TO ANY OBSTRUCTION, 50' [15M] TO ANY TEMPERATURE SENSITIVE EQUIPMENT.

NOTES:

	MEDIUM VOLTAGE LOAD BANK GENERAL REFERENCE OUTLINE DRAWING
	Model 9100 2 OF 4 Rev. -

LOAD BANK MOUNTING INSTRUCTIONS:

1. ANCHOR BOLTS SHALL BE ACQUIRED AND INSTALLED BY OTHERS. THESE NOTES ARE GUIDELINES TO BE REVIEWED BY SITE CIVIL ENGINEER OR FOUNDATION DESIGNER FOR MOUNTING OF LOAD BANK.
2. RECOMMENDED ANCHOR BOLTS SHALL BE 3/4" DIAMETER BY 6" LONG STAINLESS STEEL EXPANSION (WEDGE) ANCHORS. USE HILTI KWIK BOLT-3 OR TYPE REFERENCE: "KB-TZ SS304 3/4 x 6" OR APPROVED EQUIVALENT.
3. CORROSION RESISTANT ANCHOR BOLT SHALL BE INSTALLED PER VENDOR SUPPLIED INSTRUCTIONS.
4. ANCHOR BOLT SHALL HAVE A MINIMUM OF 2" PROJECTION ABOVE THE CONCRETE AFTER INSTALLATION.
5. PROVIDE A MINIMUM OF 8" EDGE DISTANCE FROM ANCHOR BOLT TO EDGE OF CONCRETE.
6. FOUNDATION DESIGNED AND/OR CIVIL ENGINEER SHALL REVIEW INSTALLATION. CAST IN PLACE (PRESET) OR EPOXY ANCHORS, IF USED, ARE TO BE SPECIFIED AND APPROVED BY OTHERS.
7. FULL CONCRETE PAD TO BE PER STRUCTURAL DESIGNER, ARCHITECT OR ENGINEER BUT MUST MEET THE FOLLOWING:
PAD TO BE LEVEL TO WITHIN 1/2" OVER 294" LENGTH OF LOAD BANK. PAD CAN BE SLOPED SLIGHTLY TO DRAIN OFF WATER. NO POOLING OF WATER ON PAD PERMITTED. CONCRETE TO BE CURED MINIMUM 14 DAYS BEFORE INSTALLATION. CONCRETE COMPRESSIVE STRENGTH RATING OF 3,000 PSI.
8. MOUNTING PADS AT BASE OF FOUR EXTENSION LEGS IS 7.50" BY 7.50" BY 0.75" THICK ASTM A36 STEEL WITH 1.25" CLEARANCE HOLE FOR ANCHORS.
9. KEEP AREA UNDER LOAD BANK CLEAR AND CLEAN OF ANY DEBRIS, DIRT OR WATER.

LOAD BANK GENERAL NOTES:

1. REVIEW MANUAL BEFORE HANDLING, INSTALLATION OR OPERATION.
2. SEE SHEETS 1 & 2 FOR ADDITIONAL NOTES & DETAILS.
3. ALL MEDIUM VOLTAGE ACCESS PANELS INCLUDE ONE KEY LOCK PROVISION PER DOOR AND DOOR OPEN STOPS.
4. VERTICAL EXHAUST AIR EXITS THROUGH FIXED EXHAUST HOODS. EXHAUST HOODS SHIPPED SEPARATELY.
5. MANUAL CONTROL PANEL PROVIDED LOOSE IN NEMA ENCLOSURE.
6. ALL DIMENSION ARE APPROXIMATE IN INCHES & [mm].

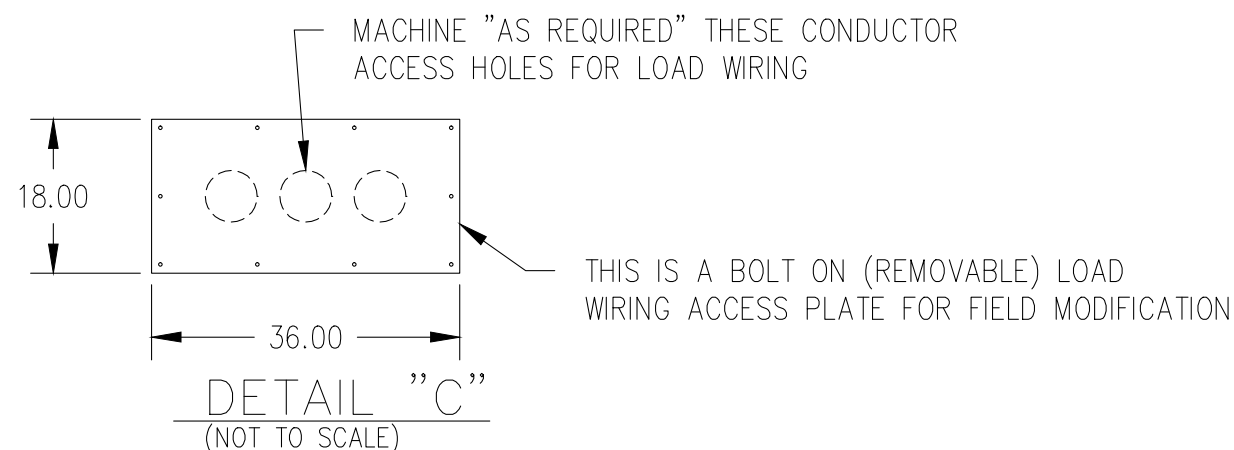
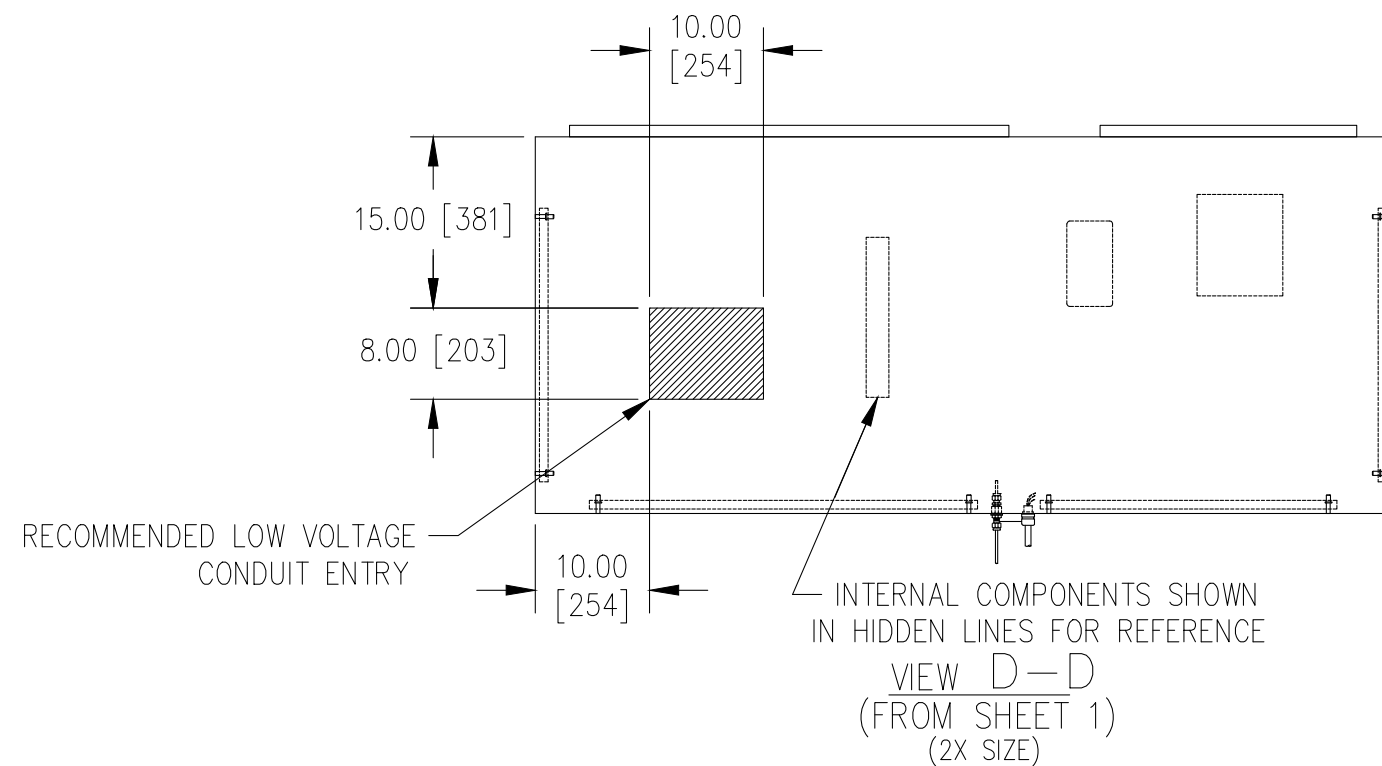

REMOVABLE (BOLT ON) INSULATION PLATE (QTY 1)
CONDUITS, STUB UPS TO COME FROM GRADE (BELOW) UNIT.
FIELD MACHINE PLATE FOR LOAD WIRING CONDUIT ENTRY



MEDIUM VOLTAGE LOAD BANK
GENERAL REFERENCE OUTLINE DRAWING

Model 9100

3 OF 4

Rev. -

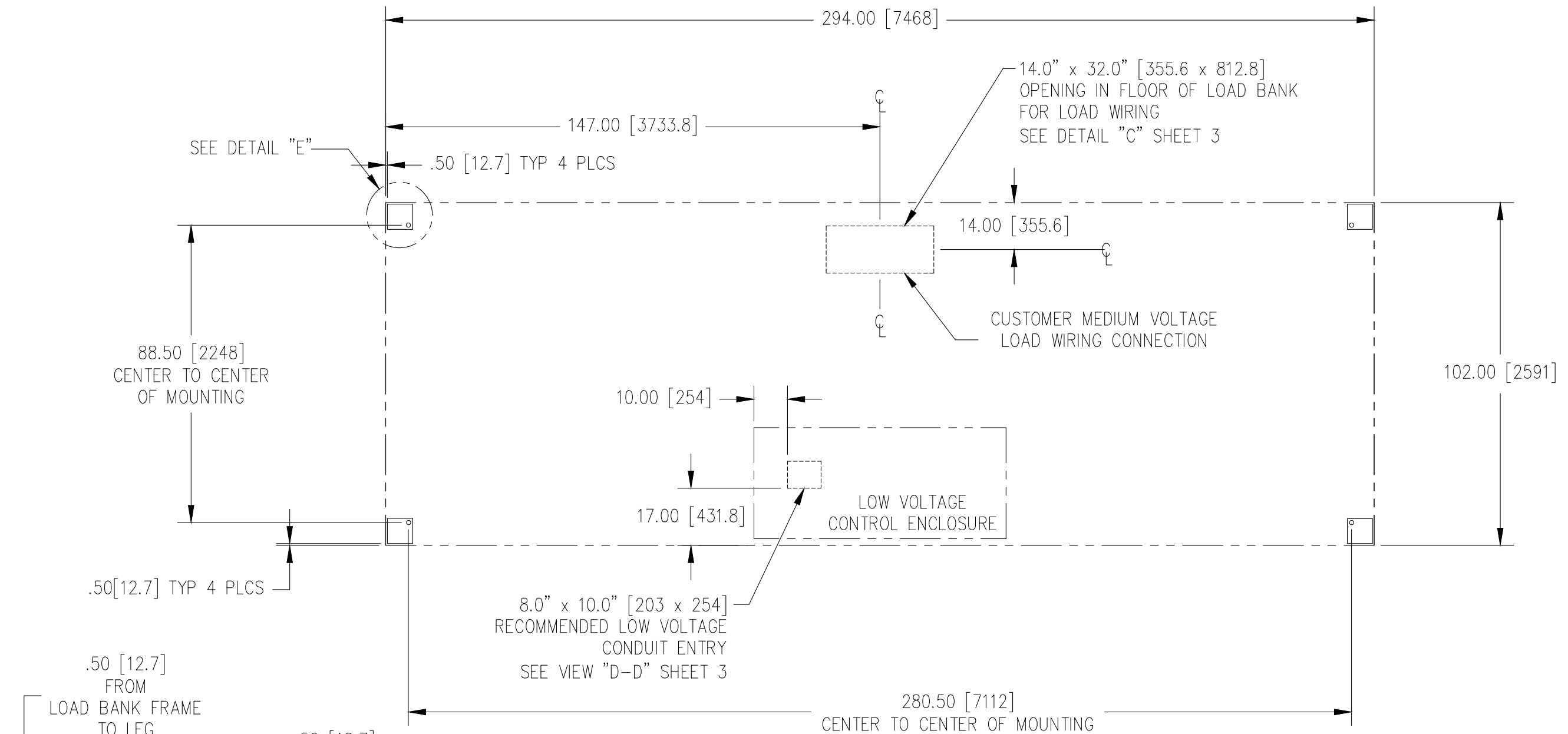

PAD PLAN VIEW

FOR ANCHORING & WIRING POINTS
(LOOKING DOWN ON UNIT, REF SECTION A-A ON SHEET 1)

DETAIL "E"

FOOT MOUNTING PAD
(TYP 4 LEGS)
7.50 x 7.50 x .50 PLATE



MEDIUM VOLTAGE LOAD BANK
GENERAL REFERENCE OUTLINE DRAWING

Model 9100

4 OF 4

Rev. -