

WINCO[®] GENERATORS

An American Company

We produce our products in our 200,000ft² facility located in Le Center, Minnesota, equipped with modern engineering, fabrication and assembly capabilities.



Light Weight

At 68 lbs, the Lil' Dog can be easily carried around the job site, workshop, or home.

Low Oil Protection

The engine will shut down in the event there is low oil pressure.

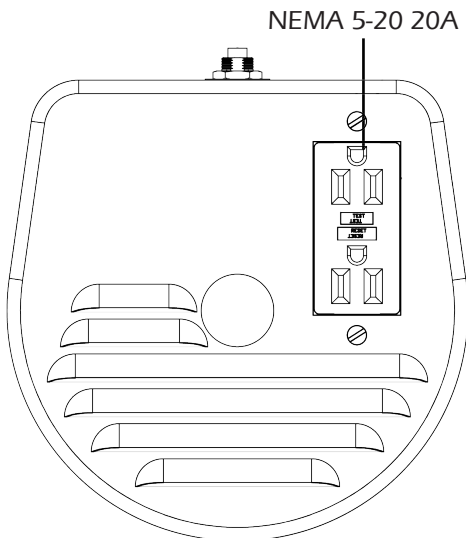

W3000H

2,200 RUNNING WATTS

Rugged Steel Design



Honda Industrial Engine

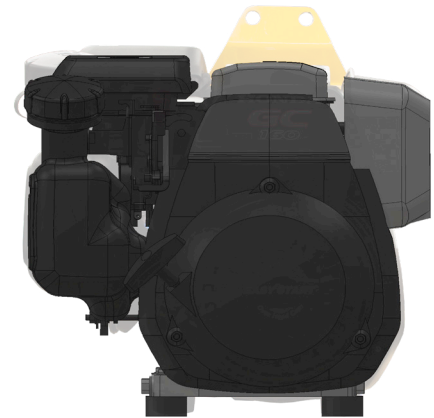

Brushless Industrial Genend. with clean power

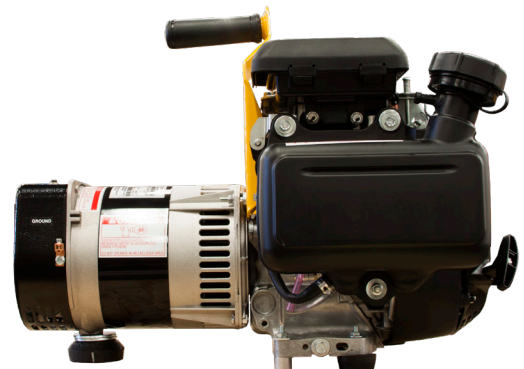

SPECIFICATIONS

ENGINE

ENGINE BRAND	HONDA
ENGINE MODEL	GC160 OHC
ENGINE STARTER	RECOIL
ENGINE SPEED	3600 RPM
ENGINE CYLINDERS	SINGLE
DISPLACEMENT/TYPE	160 CC / OHV
FREQUENCY REGULATION ⁽¹⁾	+/- 3%
LOW OIL PROTECTION	STANDARD
RECOMMENDED OIL ⁽²⁾	5W-30
OIL CAPACITY	0.61 QT
FUEL TANK	2 QT
FUEL GAUGE	NO
FULL LOAD RUN TIME ⁽³⁾	1.5 HOURS
FUEL CONSUMPTION 100%	QT/HR 1.3

NOTES: (1) Steady state frequency regulation. (2) The recommended oil is for normal applications. See operator's manual for the recommended oil for your needs. (3) Run time is estimated.

SHIPPING

SHIPPING DIMENSIONS (L x W x H)	25" x 19" x 19"
SHIP WEIGHT	72 LBS
FREIGHT CLASS	70

ELECTRICAL

STARTING WATTS	3,000
RUNNING WATTS	2,200
RUNNING AMPS @ 120 VAC	18
VOLTAGE REGULATION	CAPACITOR +/-5%
MAIN CIRCUIT BREAKER	20 AMP
BONDED NEUTRAL	YES
120 VOLT RECEPTACLES (GFCI)	(1) NEMA 5-20 20A DUPLEX
TIME METER	N/A

GENSET

MOTOR STARTING (CODE G)	0.75 HP
DBA @ 7 METERS	72
TOTAL HARMONIC DISTORTION	< 5%
LIFTING HANDLE	STANDARD
INSULATION	CLASS H
ASSEMBLED IN	USA
EPA APPROVED	YES
CARB APPROVED	NO
TÜV CERTIFICATION	CSA
UNIT WARRANTY ⁽¹⁾	1 YEARS COMMERCIAL

NOTES: (1) For more generator warranty, see operator's manual.

OPTIONAL ACCESSORIES

MAINTENANCE KIT
PLUG-IN VOLT METER

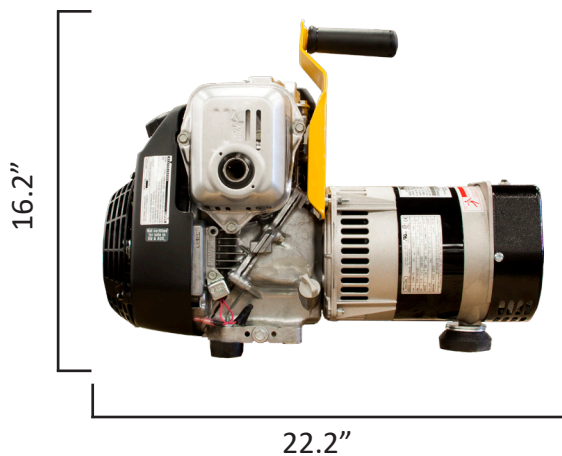

Specifications are subject to change without notice.

