

OPERATION MANUAL



MODEL DA7000SSA3 PORTABLE GENERATOR (KUBOTA Z482-E4B-DGDE-4 DIESEL ENGINE)

Revision #1 (09/18/19)

To find the latest revision of this publication or associated parts manual, visit our website at:
www.multiquip.com



THIS MANUAL MUST ACCOMPANY THE EQUIPMENT AT ALL TIMES.

PROPOSITION 65 WARNING



REPORTING SAFETY DEFECTS

If you believe that your vehicle has a defect that could cause a crash or could cause injury or death, you should immediately inform the National Highway Traffic Safety Administration (NHTSA) in addition to notifying Multiquip at 1-800-421-1244.

If NHTSA receives similar complaints, it may open an investigation, and if it finds that a safety defect exists in a group of vehicles, it may order a recall and remedy campaign. However, NHTSA cannot become involved in individual problems between you, your dealer, or Multiquip.

To contact NHTSA, you may either call the Vehicle Safety Hotline toll-free at 1-888-327-4236 (TTY: 1-800-424-9153), go to <http://www.nhtsa.dot.gov>; or write to:

Administrator
NHTSA
1200 New Jersey Avenue S.E.
Washington, DC 20590

You can also obtain information about motor vehicle safety from
<http://www.safecar.gov>.

TABLE OF CONTENTS

DA7000SSA3 Generator

Proposition 65 Warning	2
Reporting Safety Defects.....	3
Table of Contents.....	4
Nameplate/Safety Information	5
Safety Information	6–11
Specifications (Generator).....	12
Specifications (Engine).....	13
Dimensions.....	14
Installation	16–17
General Information.....	18
Components (Generator).....	19–22
Components (Engine).....	23
Load Applications	24
Inspection/Setup.....	25–29
Operation.....	30–31
Operation/Shutdown.....	32–33
Preparation for Long-Term Storage	34
Maintenance	35–42
Generator Wiring Diagram.....	43
Engine Wiring Diagram.....	44
Troubleshooting (Engine and Generator)	45
Troubleshooting (Engine).....	46–47

NOTICE

Specifications are subject to change without notice.

NAMEPLATE/SAFETY INFORMATION

NAMEPLATE AND SAFETY LABELS

Safety labels are attached to the generator as shown in Figure 1. Keep these safety labels clean at all times. When the safety labels become worn or damaged, contact your nearest dealer or the Multiquip Parts Dept.

NOTICE
For safety label part numbers, reference parts manual..

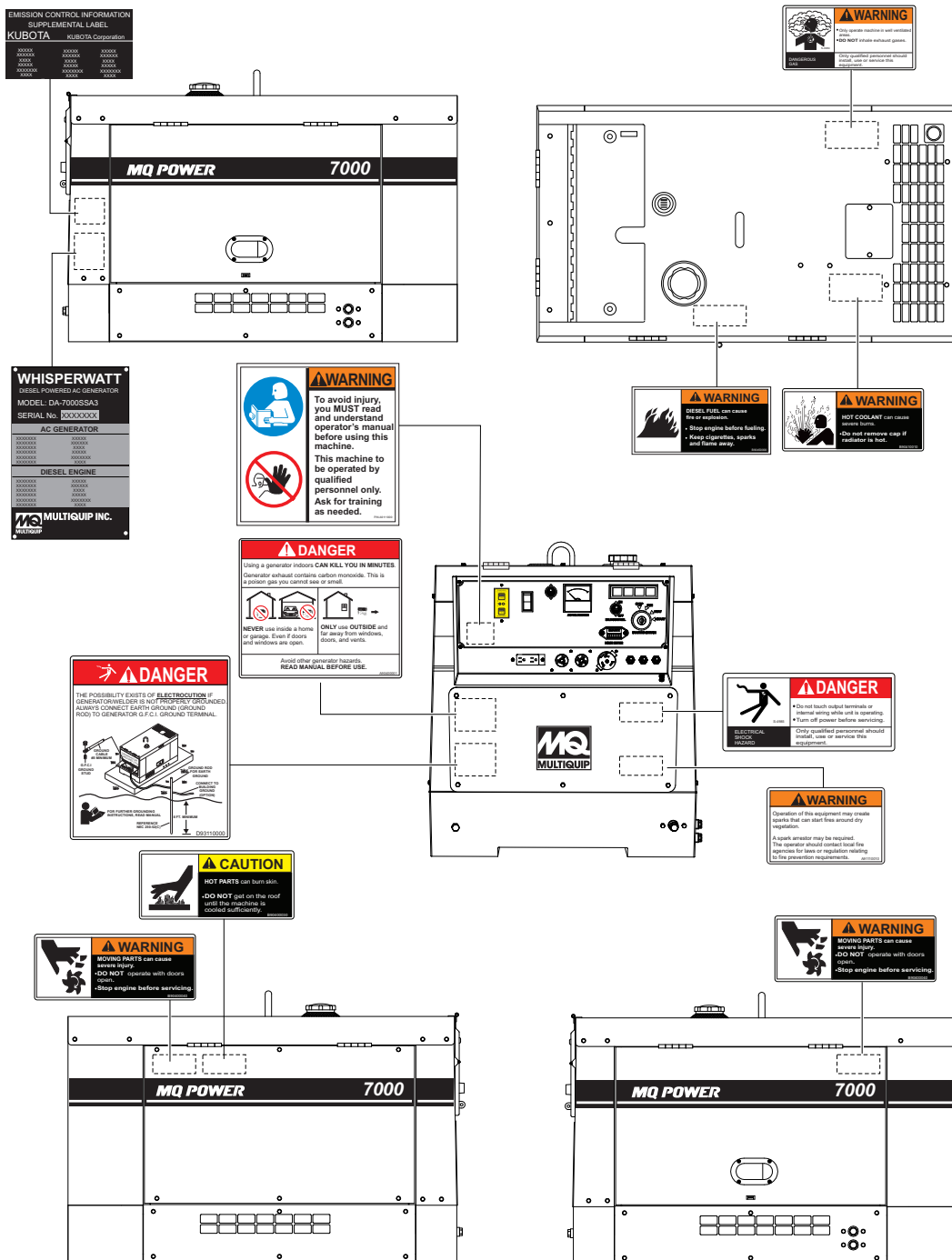

Figure 1. Nameplate And Safety Decals

SAFETY INFORMATION

Do not operate or service the equipment before reading the entire manual. Safety precautions should be followed at all times when operating this equipment. Failure to read and understand the safety messages and operating instructions could result in injury to yourself and others.

SAFETY MESSAGES

The four safety messages shown below will inform you about potential hazards that could injure you or others. The safety messages specifically address the level of exposure to the operator and are preceded by one of four words: **DANGER**, **WARNING**, **CAUTION** or **NOTICE**.

SAFETY SYMBOLS

⚠ DANGER

Indicates a hazardous situation which, if not avoided, **WILL** result in **DEATH** or **SERIOUS INJURY**.

⚠ WARNING

Indicates a hazardous situation which, if not avoided, **COULD** result in **DEATH** or **SERIOUS INJURY**.







⚠ CAUTION

Indicates a hazardous situation which, if not avoided, **COULD** result in **MINOR** or **MODERATE INJURY**.

NOTICE

Addresses practices not related to personal injury.

Potential hazards associated with the operation of this equipment will be referenced with hazard symbols which may appear throughout this manual in conjunction with safety messages.

Symbol	Safety Hazard
	Lethal exhaust gas hazards
	Explosive fuel hazards
	Burn hazards
	Overspeed hazards
	Rotating parts hazards
	Pressurized fluid hazards
	Electric shock hazards

SAFETY INFORMATION

GENERAL SAFETY

CAUTION

- **NEVER** operate this equipment without proper protective clothing, shatterproof glasses, respiratory protection, hearing protection, steel-toed boots and other protective devices required by the job or city and state regulations.



- **NEVER** operate this equipment when not feeling well due to fatigue, illness or when under medication. 
- **NEVER** operate this equipment under the influence of drugs or alcohol.



- **ALWAYS** check the equipment for loosened threads or bolts before starting.
- **DO NOT** use the equipment for any purpose other than its intended purposes or applications.

NOTICE

- This equipment should only be operated by trained and qualified personnel 18 years of age and older.
- Whenever necessary, replace nameplate, operation and safety decals when they become difficult read.
- Manufacturer does not assume responsibility for any accident due to equipment modifications. Unauthorized equipment modification will void all warranties.

- **NEVER** use accessories or attachments that are not recommended by MQ Power for this equipment. Damage to the equipment and/or injury to user may result.

- **ALWAYS** know the location of the nearest **fire extinguisher**.



- **ALWAYS** know the location of the nearest **first aid kit**.



- **ALWAYS** know the location of the nearest phone or **keep a phone on the job site**. Also, know the phone numbers of the nearest **ambulance, doctor and fire department**. This information will be invaluable in the case of an emergency.



GENERATOR SAFETY

DANGER

- **NEVER** operate the equipment in an explosive atmosphere or near combustible materials. An explosion or fire could result causing severe **bodily harm or even death**.



WARNING

- **NEVER** disconnect any **emergency or safety devices**. These devices are intended for operator safety. Disconnection of these devices can cause severe injury, bodily harm or even death. Disconnection of any of these devices will void all warranties.

CAUTION

- **NEVER** lubricate components or attempt service on a running machine.

NOTICE

- **ALWAYS** ensure generator is on level ground before use.
- **ALWAYS** keep the machine in proper running condition.
- Fix damage to machine and replace any broken parts immediately.
- **ALWAYS** store equipment properly when it is not being used. Equipment should be stored in a clean, dry location out of the reach of children and unauthorized personnel.

SAFETY INFORMATION

ENGINE SAFETY

DANGER

- The engine fuel exhaust gases contain poisonous carbon monoxide. This gas is colorless and odorless, and can cause death if inhaled.
- The engine of this equipment requires an adequate free flow of cooling air. **NEVER** operate this equipment in any enclosed or narrow area where free flow of the air is restricted. If the air flow is restricted it will cause injury to people and property and serious damage to the equipment or engine.

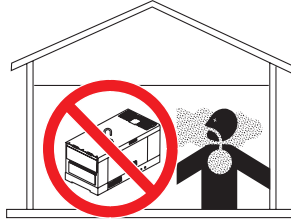

WARNING

- **DO NOT** place hands or fingers inside engine compartment when engine is running.
- **NEVER** operate the engine with heat shields or guards removed.
- Keep fingers, hands hair and clothing away from all moving parts to prevent injury.
- **DO NOT** operate generator with doors open. Stop the engine before servicing.
- **DO NOT** remove the radiator cap while the engine is hot. High pressure boiling water will gush out of the radiator and severely scald any persons in the general area of the generator.
- **DO NOT** remove the coolant drain plug while the engine is hot. Hot coolant will gush out of the coolant tank and severely scald any persons in the general area of the generator.
- **DO NOT** remove the engine oil drain plug while the engine is hot. Hot oil will gush out of the oil tank and severely scald any persons in the general area of the generator.
- Operation of the generator may create sparks that can start fires around dry vegetation, A spark arrestor may be required. The operator should contact local fire agencies for laws or regulations relating to fire prevention requirements.



CAUTION

- **NEVER** touch the hot exhaust manifold, muffler or cylinder. Allow these parts to cool before servicing equipment.



NOTICE

- **NEVER** run engine without an air filter or with a dirty air filter. Severe engine damage may occur. Service air filter frequently to prevent engine malfunction.
 - **NEVER** tamper with the factory settings of the engine or engine governor. Damage to the engine or equipment can result if operating in speed ranges above the maximum allowable.
 - Wet stacking is a common problem with diesel engines which are operated for extended periods with light or no load applied. When a diesel engine operates without sufficient load (less than 30–35% of the rated output), it will not operate at its optimum temperature. This will allow unburned fuel to accumulate in the exhaust system, which can foul the fuel injectors, engine valves and exhaust system, including turbochargers, and reduce the operating performance.
- In order for a diesel engine to operate at peak efficiency, it must be able to provide fuel and air in the proper ratio and at a high enough engine temperature for the engine to completely burn all of the fuel.
- Wet stacking does not usually cause any permanent damage and can be alleviated if additional load is applied to relieve the condition. It can reduce the system performance and increase maintenance. Applying an increasing load over a period of time until the excess fuel is burned off and the system capacity is reached usually can repair the condition. This can take several hours to burn off the accumulated unburned fuel.
- State Health Safety Codes and Public Resources Codes specify that in certain locations, spark arresters must be used on internal combustion engines that use hydrocarbon fuels. A spark arrester is a device designed to prevent accidental discharge of sparks or flames from the engine exhaust. Spark arresters are qualified and rated by the United States Forest Service for this purpose. In order to comply with local laws regarding spark arresters, consult the engine distributor or the local Health and Safety Administrator.



SAFETY INFORMATION

FUEL SAFETY

DANGER

- **DO NOT** start the engine near spilled fuel or combustible fluids. Diesel fuel is extremely flammable and its vapors can cause an explosion if ignited.
- **ALWAYS** refuel in a well-ventilated area, away from sparks and open flames.
- **ALWAYS** use extreme caution when working with **flammable** liquids.
- **DO NOT** fill the fuel tank while the engine is running or hot.
- **DO NOT** overfill tank, since spilled fuel could ignite if it comes into contact with hot engine parts or sparks from the ignition system.
- Store fuel in appropriate containers, in well-ventilated areas and away from sparks and flames.
- **NEVER** use fuel as a cleaning agent.
- **DO NOT** smoke around or near the equipment. Fire or explosion could result from fuel vapors or if fuel is spilled on a hot engine.



TOWING SAFETY

CAUTION

- Check with your local county or state safety towing regulations, in addition to meeting **Department of Transportation (DOT) Safety Towing Regulations**, before towing your generator.
- Refer to MQ Power trailer manual for additional safety information.
- In order to reduce the possibility of an accident while transporting the generator on public roads, **ALWAYS** make sure the trailer that supports the generator and the towing vehicle are mechanically sound and in good operating condition.
- **ALWAYS** shutdown engine before transporting



- Make sure the hitch and coupling of the towing vehicle are rated equal to, or greater than the trailer “gross vehicle weight rating.”
- **ALWAYS** inspect the hitch and coupling for wear. **NEVER** tow a trailer with defective hitches, couplings, chains, etc.
- Check the tire air pressure on both towing vehicle and trailer. **Trailer tires should be inflated as indicated on sidewall of tire.** Also check the tire tread wear on both vehicles.
- **ALWAYS** make sure the trailer is equipped with a **safety chain**.
- **ALWAYS** properly attach trailer’s safety chains to towing vehicle.
- **ALWAYS** make sure the vehicle and trailer directional, backup, brake and trailer lights are connected and working properly.
- DOT Requirements include the following:
 - Connect and test electric brake operation.
 - Secure portable power cables in cable tray with tie wraps.
- The maximum speed for highway towing is **55 MPH** unless posted otherwise. Recommended off-road towing is not to exceed **15 MPH** or less depending on type of terrain.
- Avoid sudden stops and starts. This can cause skidding, or jack-knifing. Smooth, gradual starts and stops will improve towing.
- Avoid sharp turns to prevent rolling.
- Trailer should be adjusted to a level position at all times when towing.
- Raise and lock trailer wheel stand in up position when towing.
- Place **chock blocks** underneath wheel to prevent **rolling** while parked.
- Place **support blocks** underneath the trailer’s bumper to prevent **tipping** while parked.
- Use the trailer’s swivel jack to adjust the trailer height to a level position while parked.

SAFETY INFORMATION

ELECTRICAL SAFETY

DANGER

- **DO NOT** touch output terminals during operation. Contact with output terminals during operation can cause **electrocution, electrical shock or burn.**

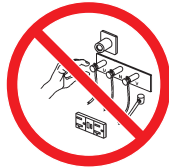

- The electrical voltage required to operate the generator can cause severe injury or even death through physical contact with live circuits. Turn generator and all circuit breakers **OFF** before performing maintenance on the generator or making contact with output terminals.

- **NEVER** insert any objects into the output receptacles during operation. This is extremely dangerous. The possibility exists of **electrical shock, electrocution or death.**



- Backfeed to a utility system can cause **electrocution** and/or property damage. **NEVER** connect the generator to a building's electrical system without a transfer switch or other approved device. All installations should be performed by a **licensed electrician** in accordance with all applicable laws and electrical codes. Failure to do so could result in electrical shock or burn, causing **serious injury or even death.**



Power Cord/Cable Safety

DANGER

- **NEVER** let power cords or cables **lay in water.**
- **NEVER stand in water** while AC power from the generator is being transferred to a load.
- **NEVER** use **damaged** or **worn** cables or cords when connecting equipment to generator. Inspect for cuts in the insulation.
- **NEVER** grab or touch a live power cord or cable with wet hands. The possibility exists of **electrical shock, electrocution or death.**

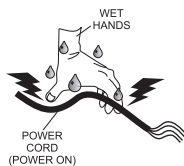

- Make sure power cables are securely connected to the generator's output receptacles. Incorrect connections may cause electrical shock and damage to the generator.

NOTICE

- **ALWAYS** make certain that proper power or extension cord has been selected for the job. See Cable Selection Chart in this manual.

Grounding Safety

DANGER

- **ALWAYS** make sure that electrical circuits are properly grounded to a suitable earth ground (ground rod) per the National Electrical Code (NEC) and local codes before operating generator. **Severe injury or death by electrocution** can result from operating an ungrounded generator.
- **NEVER** use gas piping as an electrical ground.

BATTERY SAFETY

DANGER

- **DO NOT** drop the battery. There is a possibility that the battery will explode.
- **DO NOT** expose the battery to open flames, sparks, cigarettes, etc. The battery contains combustible gases and liquids. If these gases and liquids come into contact with a flame or spark, an explosion could occur.



WARNING

- **ALWAYS** wear safety glasses when handling the battery to avoid eye irritation. The battery contains acids that can cause injury to the eyes and skin.
- Use well-insulated gloves when picking up the battery.
- **ALWAYS** keep the battery charged. If the battery is not charged, combustible gas will build up.
- **ALWAYS** recharge the battery in a well-ventilated environment to avoid the risk of a dangerous concentration of combustible gasses.



- If the battery liquid (dilute sulfuric acid) comes into contact with **clothing or skin**, rinse skin or clothing immediately with plenty of water.
- If the battery liquid (dilute sulfuric acid) comes into contact with **eyes**, rinse eyes immediately with plenty of water and contact the nearest doctor or hospital to seek medical attention.

CAUTION

- **ALWAYS** disconnect the **NEGATIVE battery terminal** before performing service on the generator.
- **ALWAYS** keep battery cables in good working condition. Repair or replace all worn cables.

ENVIRONMENTAL SAFETY/DECOMMISSIONING

NOTICE

Decommissioning is a controlled process used to safely retire a piece of equipment that is no longer serviceable. If the equipment poses an unacceptable and unrepairable safety risk due to wear or damage or is no longer cost effective to maintain (beyond life-cycle reliability) and is to be decommissioned (demolition and dismantlement), be sure to follow rules below.

- **DO NOT** pour waste or oil directly onto the ground, down a drain or into any water source.
- Contact your country's Department of Public Works or recycling agency in your area and arrange for proper disposal of any electrical components, waste or oil associated with this equipment.
- When the life cycle of this equipment is over, remove battery and bring to appropriate facility for lead reclamation. Use safety precautions when handling batteries that contain sulfuric acid.
- When the life cycle of this equipment is over, it is recommended that the frame and all other metal parts be sent to a recycling center.



Metal recycling involves the collection of metal from discarded products and its transformation into raw materials to use in manufacturing a new product.

Recyclers and manufacturers alike promote the process of recycling metal. Using a metal recycling center promotes energy cost savings.

EMISSIONS INFORMATION

NOTICE

The diesel engine used in this equipment has been designed to reduce harmful levels of carbon monoxide (CO), hydrocarbons (HC) and nitrogen oxides (NOx) contained in diesel exhaust emissions.

This engine has been certified to meet US EPA Evaporative emissions requirements in the installed configuration.

Attempting to modify or make adjustments to the engine emission system by unauthorized personnel without proper training could damage the equipment or create an unsafe condition.

Additionally, modifying the fuel system may adversely affect evaporative emissions, resulting in fines or other penalties.

Emission Control Label

The emission control label is an integral part of the emission system and is strictly controlled by regulations.

The label must remain with the engine for its entire life.

If a replacement emission label is needed, please contact your authorized engine distributor.

SPECIFICATIONS (GENERATOR)

Table 1. Specifications (Generator)		
AC Generator 60 Hz AC Power Source	Model	DA7000SSA3
	Type	2-Pole Brushless Revolving Field Type
	Excitation	Solid State, Statically Excited System
	Speed	3,600 RPM
	Cooling System	Self-Ventilation
	Max Power Output	7 kW
	Continuous Power Output	6 kW
	Rated Voltage	120/240V
	Current Max/Continuous (120V)	58.3/50 amps
	Current Max/Continuous (240V)	29.2/25 amps
	Phase	Single Phase (4 wire)
	Frequency	60 Hz
	Power Factor	1
Battery	12 -35Ah x 1	
Dimensions (L x W x H)	44.9 X 25.6 X 31.3 in. (1,140 X 650 X 795 mm)	
Dry Weight	534 lbs. (242 kg)	
Wet Weight	598 lbs. (271 kg)	

NOTICE

In keeping with Multiquip's policy of constantly improving its products, the specifications quoted herein are subject to change without prior notice.

SPECIFICATIONS (ENGINE)

Table 2. Specifications (Engine)

Engine	Kubota Engine Model	Z482-E4B-DGDE-4
	Tier	4
	Gen. Enclosure Color	White
	Type	Vertical, water-cooled, 4-cycle diesel engine
	Bore X Stroke	2.64 in. X 2.68 in. (67 mm x 68 mm.)
	Displacement	29.23 cu.-in. (479 cm ³)
	Number of Cylinders	2
	Max Output	12.5~13.9 H.P./3600 R.P.M.
	Fuel	#2 Diesel Fuel
	Fuel Capacity	6.6 gal. (25 liters)
	Fuel Consumption	0.69 gals. (2.63 liters)/hr.
	Coolant Capacity	2.95 quarts (2.8 liters)
	Lube Oil Capacity	2.64 quarts (2.5 liters)
	Oil Alert System	Yes
	Starting Method	Electric Start
Battery	12 Volt @ 35 Ah	

Effects of Altitude and Heat

The maximum output of the engines listed above are applicable to supplying electrical power for continuous service at ambient conditions in accordance with SAE Test cord J607. The above ambient conditions are at standard sea level, with a barometric reading of 29.92 inches and a temperature of 60° F (15.5° C).

Generally, the engine's output power will decrease 3-1/2% for each 1000 feet (305 meters) of altitude above sea level, and 1% for each 10° F (-12.2° C) above the standard temperature of 60° F (15.5° C).

DIMENSIONS

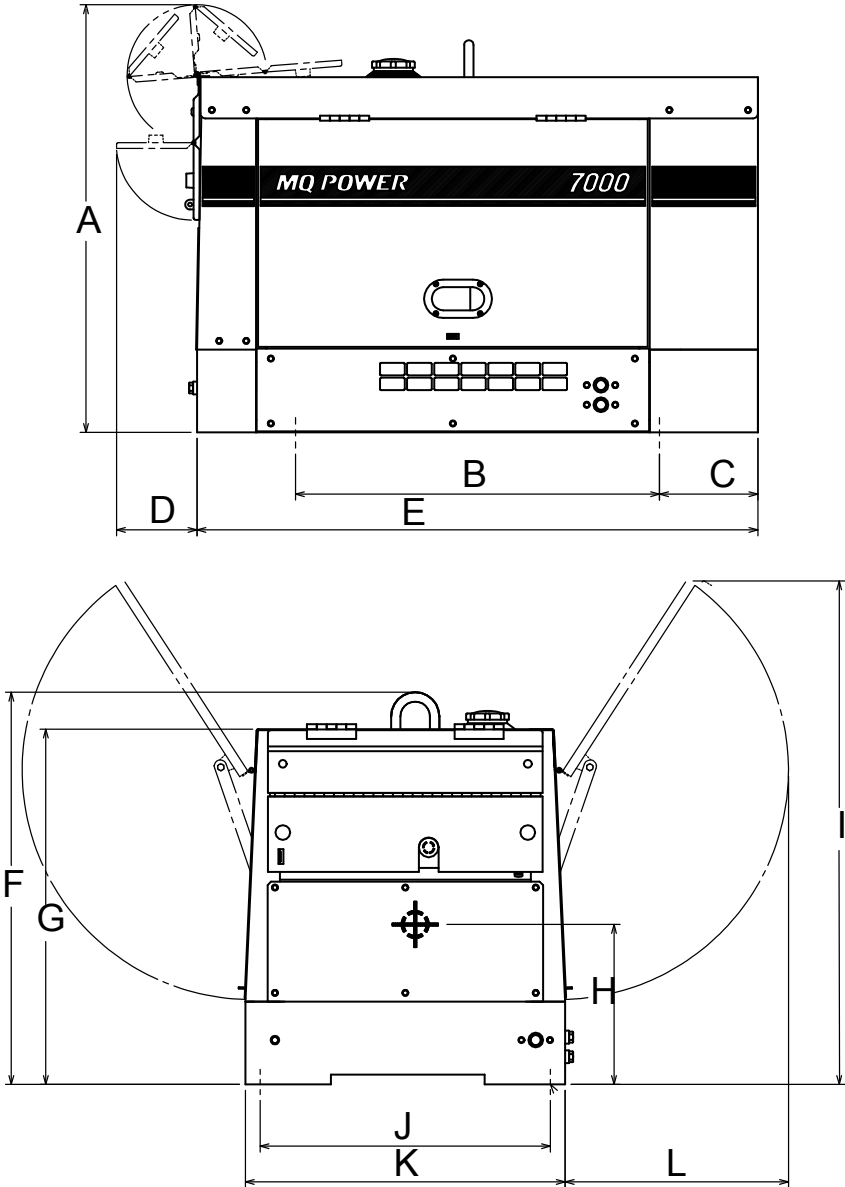

Figure 2. Dimensions

Table 3. Dimensions				
Housing	A	B	C	D
	approx. 34.3 in (870 mm)	29.1 in (740 mm)	7.9 in (200 mm)	approx. 6.5 in (165 mm)
	E	F	G	H
	44.9 in (1140 mm)	31.3 in (795 mm)	28.3 in (720 mm)	12.8 in (325 mm)
I	J	K	L	
approx. 40.4 in (1025 mm)	23.2 in (590 mm)	25.6 in (650 mm)	approx. 17.9 in (455 mm)	
Approx. Dry Weight	534 lbs (242 kg)			
Approx. Wet Weight	598 lbs (271 kg)			

INSTALLATION

CONNECTING THE GROUND

Consult with local Electrical and Safety Codes for proper connection based on condition of use.

EXAMPLE of how to ground the unit if the condition of use requires such a device:

The ground terminal on the generator should always be used to connect the generator to a suitable ground when required.

Either copper or aluminum wire can be used as the ground cable. Cable size is determined by the maximum amperage of the generator. Reference Conductor Grounding Table, Article 250 of the NEC handbook.

Connect one end of the ground cable terminal to the generator ground point (Figure 3). Connect the other end of the ground cable to a suitable earth ground (ground rod).

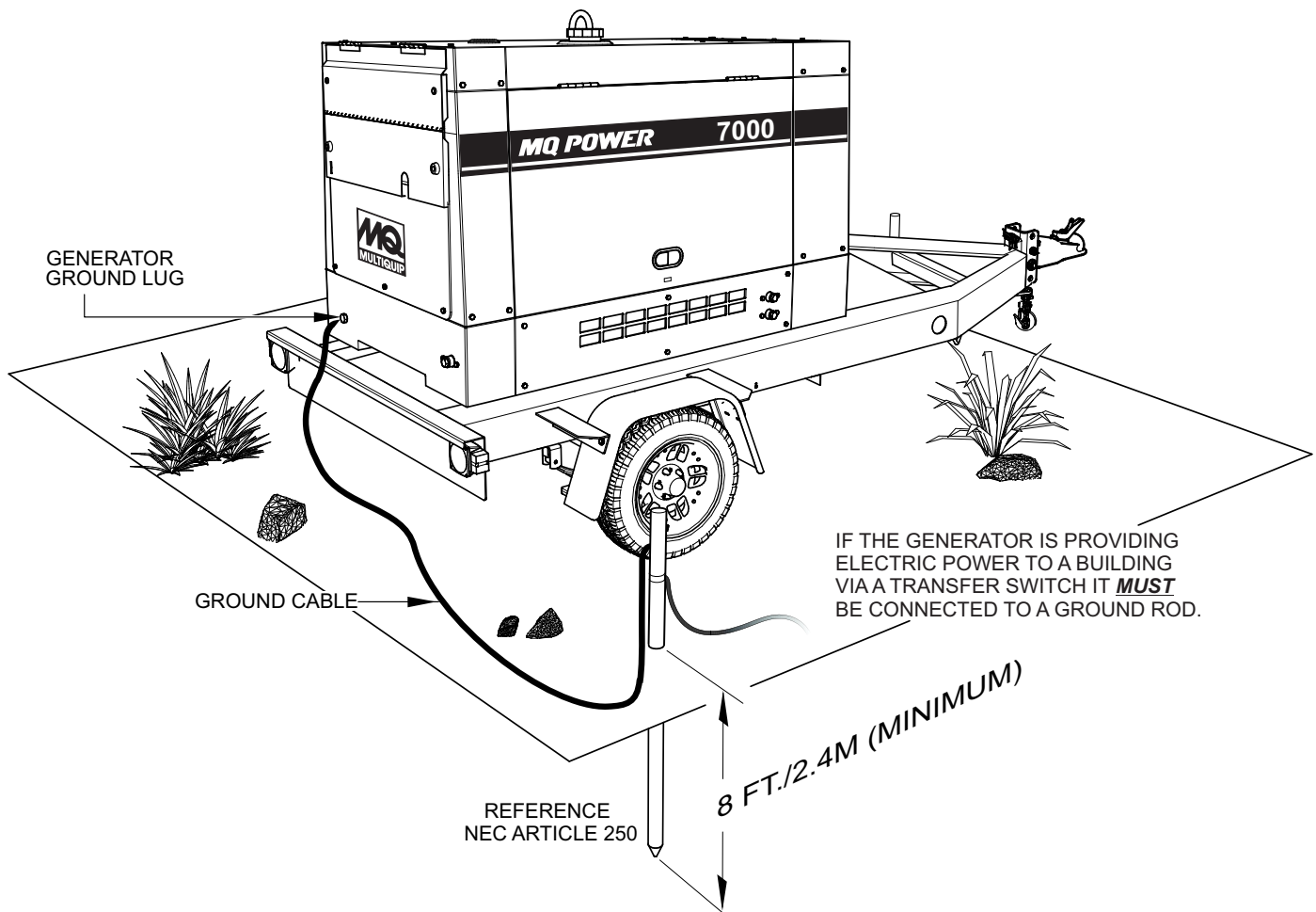

Figure 3. Generator Grounding

OUTDOOR INSTALLATION

Install the generator in an area that is free of debris, bystanders, and overhead obstructions. Make sure the generator is on secure level ground so that it cannot slide or shift around. Also install the generator in a manner so that the exhaust will not be discharged in the direction of nearby homes.

The installation site must be relatively free from moisture and dust. All electrical equipment should be protected from excessive moisture. Failure to do will result in deterioration of the insulation and will result in short circuits and grounding.

Foreign materials such as dust, sand, lint and abrasive materials have a tendency to cause excessive wear to engine and alternator parts.

CAUTION

Pay close attention to ventilation when operating the generator inside tunnels and caves. The engine exhaust contains noxious elements. Engine exhaust must be routed to a ventilated area.

INDOOR INSTALLATION

Exhaust gases from diesel engines are extremely poisonous. Whenever an engine is installed indoors the exhaust fumes must be vented to the outside. The engine should be installed at least two feet from any outside wall. Using an exhaust pipe which is too long or too small can cause excessive back pressure which will cause the engine to heat excessively and possibly burn the valves.

MOUNTING

The generator must be mounted on a solid foundation (such as concrete) and set firmly on the foundation to isolate vibration of the generator when it is running. The generator must be mounted at least 6 inches above the floor or grade level as referenced in the National Fire Protection Association (NFPA 110, Chapter 7, section 7.4) handbook.

DO NOT remove the metal skids on the bottom of the generator. They are to resist damage to the bottom of the generator and to maintain alignment.

GENERATOR GROUNDING

NOTICE

The Occupational Safety and Health Administration (OSHA) and the National Electrical Code (NEC) recommend that if the generator is providing electrical power to a structure (home, office shop, trailer or similar) it **must** be connected to a grounding electrode system, such a driven ground rod (Figure 3).

If applicable, to guard against electrical shock and possible damage to the equipment, it is important to provide a good **EARTH** ground, (Figure 3).

NOTICE

ALWAYS check with State, Province, District and Municipalities for electrical grounding requirements before using generator.

Article 250 (Grounding) of the NEC handbook provides guidelines for proper grounding and specifies that the cable ground shall be connected to the grounding system of the building as close to the point of cable entry as practical.

1. Use one of the following wire types to connect the generator to earth ground.
 - a. Copper
 - b. Aluminum

NOTICE

Reference Conductor Grounding Table, Article 250 of the NEC handbook for proper conductor wire size. Wire size is determined by the maximum amperage of the generator.

2. When grounding of the generator (Figure 3) is required, connect one end the ground cable to the ground lug on the generator. Connect the other end of the ground cable to the ground rod (earth ground).
3. NEC Article 250 specifies that the earth ground rod should be buried a minimum of 8 ft. into the ground.

NOTICE

When connecting the generator to any buildings electrical system **ALWAYS** consult with a licensed electrician.

GENERAL INFORMATION

Generator

The Multiquip DA7000SSA3 is a 6.0 kW (continuous output), 7.0 kW (max output) A.C. generator designed as a portable dual purpose power source for 60 Hz (single phase), 120/240V for lighting facilities, power tools, submersible pumps and other industrial and construction machinery.

Control Panel

The control box is provided with the following:

- 120 VAC Receptacle (5-20R)
- 120 Twist-Lock Output Receptacle (L5-30R)
- 120/240 V Twist-Lock Output Receptacle (L14-30R)
- 120/240 V Twist-Lock Output Receptacle (CS6369)
- AC Voltmeter
- GFCI Sensing Module
- Main Circuit Breaker @25 Amps
- 30 Amp Circuit Breaker (for L14-30R)
- 30 Amp Circuit Breaker (for L5-30R)
- 20 Amp Circuit Breaker (for 5-20R)
- Idle Control Switch
- Full Power Switch
- Starter Switch
- Warning Lamp Unit
- Hour Meter
- Ground Terminal

Engine Protection System

Engine protection fail safe features are provided in the event of low oil pressure, high coolant temperature and failure of the battery to charge. If any of the above conditions occur while operating the generator it will cause a complete unit shut down.

Battery Charge Alarm

This unit is equipped with a protective shutdown device that signals the emergency relay and automatically stops the engine when loss of charge from the engine alternator occurs. An indicator lamp will be displayed on the control panel.

Water Temperature Alarm

This unit is equipped with a temperature switch that signals the emergency relay and automatically stops the engine when the temperature of the engine coolant becomes abnormally high.

The coolant temperature switch will not function properly if the machine is operated with less than the proper amount of coolant.

Oil Pressure Warning Alarm

This unit is equipped with an oil pressure switch that detects low oil pressure. If the lubricating oil pressure of this unit should become abnormally low, the oil pressure switch signals the emergency relay to shutdown the engine. If this condition should occur, please refer to the engine troubleshooting table in this manual.

Idle Control Switch

The DA7000SSA3 generator is provided with an automatic idle (engine) control capability for noise suppression and fuel cost reduction. The automatic idle control feature automatically engages under a no-load condition when the switch is in the ON position.

With AC loads of more than 100W (such as lighting equipment, motor-powered tools, submersible water pumps, etc.), the engine runs at high speed. When a no load condition is produced, the engine automatically slows down.

Turn the idle control switch to the "ON" (up) position when AC loads drawing more than 150W are connected. Turn the idle control switch to the "OFF" (down) position when AC loads drawing less than 100W or when a magnetic switch is used.

Excitation System

The DA7000SSA3 generators use a brushless exciter to create rated output electricity. This system will use the mechanical energy generated by the 3600 RPM engine to spin the rotor (or armature) inside the generator (or alternator end).

Excitation current is sourced from the battery to the excitation winding in the stator. Current applied to this coil creates a magnetic field. The rotating armature within the stator is then induced with AC current.

Engine

The DA7000SSA3 generator is powered by a water-cooled, 4-cycle KUBOTA diesel engine. This engine is designed to meet every performance requirement of the generator. Reference Table 2, engine specifications.

In keeping with Multiquip's policy of constantly improving its products, the specifications quoted herein are subject to change without prior notice.

COMPONENTS (GENERATOR)

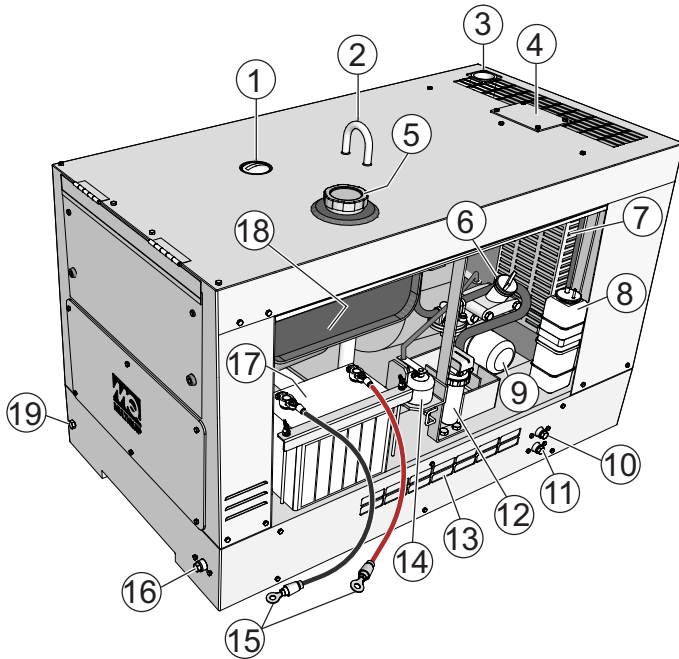

Figure 4. Generator Components (1 of 3)

1. **Fuel Gauge** — Indicates the amount of fuel in the fuel tank.
2. **Lifting Hook** — Use this hook to lift the generator. Maximum weight is 598 lbs. (271 kg).
3. **Air Outlet Exhaust** — Allows engine exhaust to exit the generator into the open air. **NEVER** block this opening.
4. **Radiator Cap Access Cover**— Remove this cover to gain access to radiator cap.
5. **Fuel Cap** — Remove this cap to add fuel. Add only #2 Diesel Fuel. Always keep an adequate amount of fuel in the tank. **DO NOT** top off. Wipe up any spilled fuel immediately.
6. **Engine Oil Filler Port** — Remove this cap to add engine oil. Use only the recommended oil type. See Table 6.
7. **Radiator** — Provides coolant to engine block.
8. **Expansion Bottle** — Supplies coolant to the radiator when radiator coolant level is low. Fill to indicated level as shown on expansion bottle.
9. **Oil Filter** — Provides filtering for the engine oil. Change oil filter as recommended in the maintenance section of this manual.
10. **Coolant Drain Plug** — Remove this plug to drain coolant from the radiator.
11. **Oil Drain Plug** — Remove this plug to drain oil from the engine.
12. **Fuel Filter** — Prevents dirt and other debris from entering the fuel system. Replace filter as recommended in the maintenance section of this manual.
13. **Air Inlet Vent** — Allows outside air to enter the generator. **NEVER** block this opening.
14. **Automatic Idle Control Solenoid** — Automatically regulates engine speed depending on load.
15. **Battery Terminals** — Connect cables to the terminals on the battery. Always pay close attention to the polarity of the terminals when connecting to the battery, **RED** (positive), and **BLACK** (negative).
16. **Fuel Drain Plug** — Remove this plug to drain fuel from the fuel tank.
17. **Battery** — Provides +12 VDC power for the generator. When replacing battery (12V 35 AH) use only recommended type battery.
18. **Fuel Tank** — Holds 6.6 gallons (25 liters) of diesel fuel.
19. **Frame Ground Terminal** — Connect a ground strap between this lug and a ground rod. Make sure that the ground rod terminal is inserted deep into the ground to provide a good earth ground. Consult with local Electrical and Safety Codes for proper connection based on condition of use.

COMPONENTS (GENERATOR)

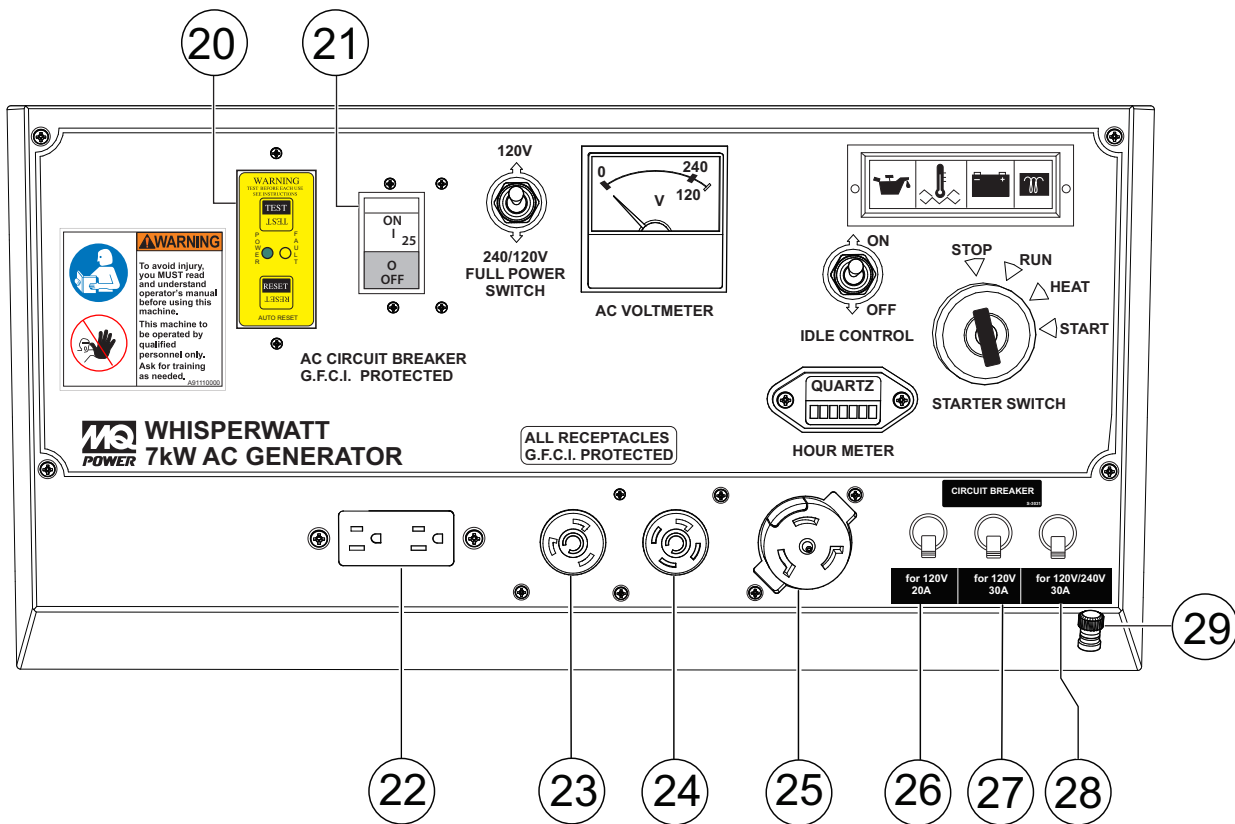

Figure 5. Generator Components (2 of 3)

- 20. **GFCI Sensing Module** — Interrupts power, by opening the main breaker, when a ground fault exists.
- 21. **Main Breaker** — 2-pole, 25 Amp circuit breaker protects the generator from short circuiting or overloading. When starting the generator, always have this circuit breaker placed in the **OFF** position. Also protects the CS6369 receptacle.
- 22. **NEMA 5-20R Duplex Receptacle** — Provides 120V, 60 Hz output at 20 amps.
- 23. **NEMA L5-30R Receptacle** — Twist-lock receptacle provides 120V, 60 Hz output at 30 amps, depending on the position of the full power switch.
- 24. **NEMA L14-30R Receptacle** — Twist-lock receptacle provides 240V, 60 Hz output at 15 amps, or 120V, 60 Hz at 30 amps, depending on the position of the full power switch.
- 25. **CS6369 Receptacle** — Twist-lock receptacle provides 240V, 60 Hz output at 25 amps, or 120V, 60 Hz at 50 amps, depending on the position of the full power switch.
- 26. **20 Amp Breaker (for 5-20R)** — Single-pole, 20 Amp circuit breaker protects the 120V duplex receptacle. When starting the generator, always have this circuit breaker placed in the "OFF" position.
- 27. **30 Amp Breaker (for L5-30R)** — Single-pole, 30 Amp circuit breaker protects the 120V twist-lock receptacle. When starting the generator, always have this circuit breaker placed in the "OFF" position.
- 28. **30 Amp Breaker (for L14-30R)** — 2-pole, 30 Amp circuit breaker protects the 120/240V twist-lock receptacle. When starting the generator, always have this circuit breaker placed in the "OFF" position.
- 29. **Ground Terminal GFCI Module** — Used to connect external equipment grounds so that the GFCI sensing module will have a ground path.

COMPONENTS (GENERATOR)

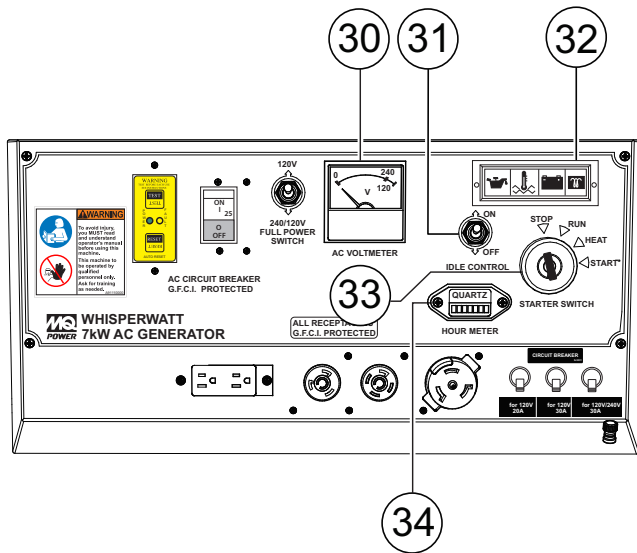

Figure 6. Generator Components (3 of 3)

30. **AC Voltmeter** — This voltmeter indicates (with a mark) the rated 60 Hz (single-phase) output voltage. In addition the voltmeter can also be used as a diagnostic tool. If the voltmeter indicator (needle) is below the rated voltage, engine problems may exist (low/high RPM's). To prevent damage to the generator or power tools turn the generator **OFF** and consult your authorized Multiquip service dealer.

31. **Idle Control Switch** — The generator is provided with an automatic idle control device for noise suppression and reduced fuel consumption.

The automatic idle control automatically engages under a no-load condition. With the automatic idle control switched **ON**, the engine revolutions will automatically drop to about 2200 rpm (low-speed operation) within 3 seconds after the load stops. When the operation is resumed, the engine speed is automatically increased to about 3600 rpm (high-speed operation) as soon as the load is connected.

32. **Engine Warning Lamps** — There are four engine warning lamps, they are defined as follows:

a. **Low Oil Pressure Alarm Lamp** — During normal operation of the generator this lamp will remain OFF. When the ignition switch is placed in the RUN position to start the engine, the lamp will be ON. When the oil pressure rises after start-up the lamp will go OFF.



If this lamp is ever lit (**ON**) during normal operation of the generator, the emergency shutdown system will stop the engine automatically.

b. **Water Temperature Alarm Lamp** — This lamp goes ON when the cooling water temperature rises abnormally. If the lamp goes ON during normal operation of the generator, the emergency shutdown system will stop the engine automatically.



c. **Battery Charge Alarm Lamp** — This lamp is ON when the output voltage of the alternator drops below a set value. If this lamp is ON during normal operation, the emergency shutdown system will immediately stop the engine.



d. **Pre-Heat Lamp** — The pre-heat lamp will be ON during the pre-heating cycle (cold weather conditions). When the pre-heat cycle is completed the lamp will turn OFF and the engine can be started.

In addition this lamp displays engine trouble shooting faults via flashes (blinking). See engine trouble codes in the maintenance section of this manual.

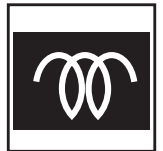

33. **Starter Switch** — With key inserted turn clockwise to start engine.

34. **Hour Meter** — Indicates number of hours machine has been in use or hours engine was run.

COMPONENTS (GENERATOR)

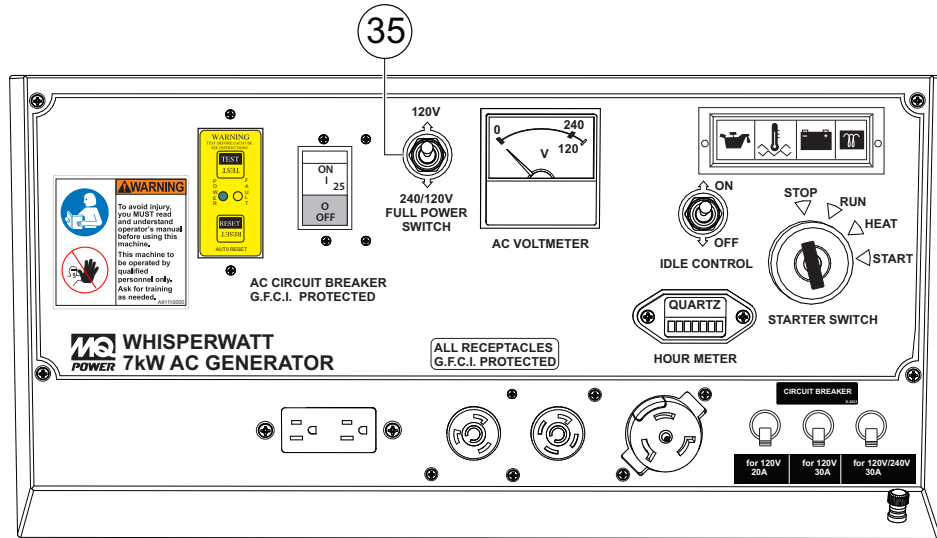

Figure 7. Full Power Switch

35. **Full Power Switch** — The generator is provided with a full power switch. See Figure 8 and Figure 9 for simplified wiring diagrams of the dual voltage system.

When the full power switch is in the 120 volt position (up), you can access the full rated power of the generator at 120 volts from the duplex receptacle and the 120 volt twist-lock receptacle, or a combination of both receptacles as long as the total load does not exceed the generating set capacity.

When the full power switch is in the 240 volt position (down), you can access half of the rated power of the generator at 120 volts from the duplex receptacle and up to half of the rated power of the generator at 120 volts from the 120 volt twist-lock receptacle, or full rated power of the generator at 240 volts from the 240V twist-lock receptacle.

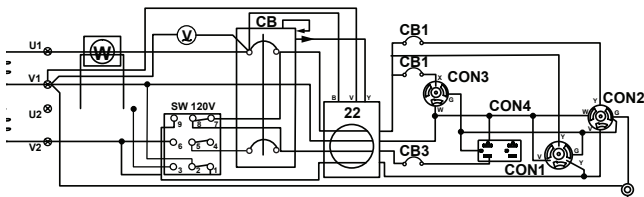

Figure 8. 120V Full Power Switch Simplified Diagram (Up Position)

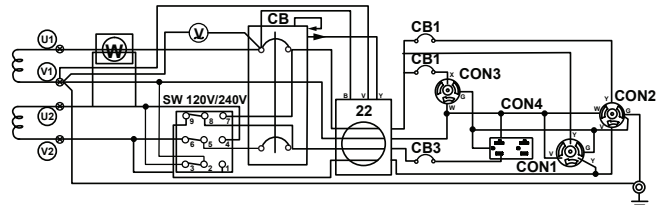

Figure 9. 240/120V Full Power Switch Simplified Diagram (Down Position)

NOTICE

When using a combination of receptacles, total load should not exceed the rated capacity of the generator.

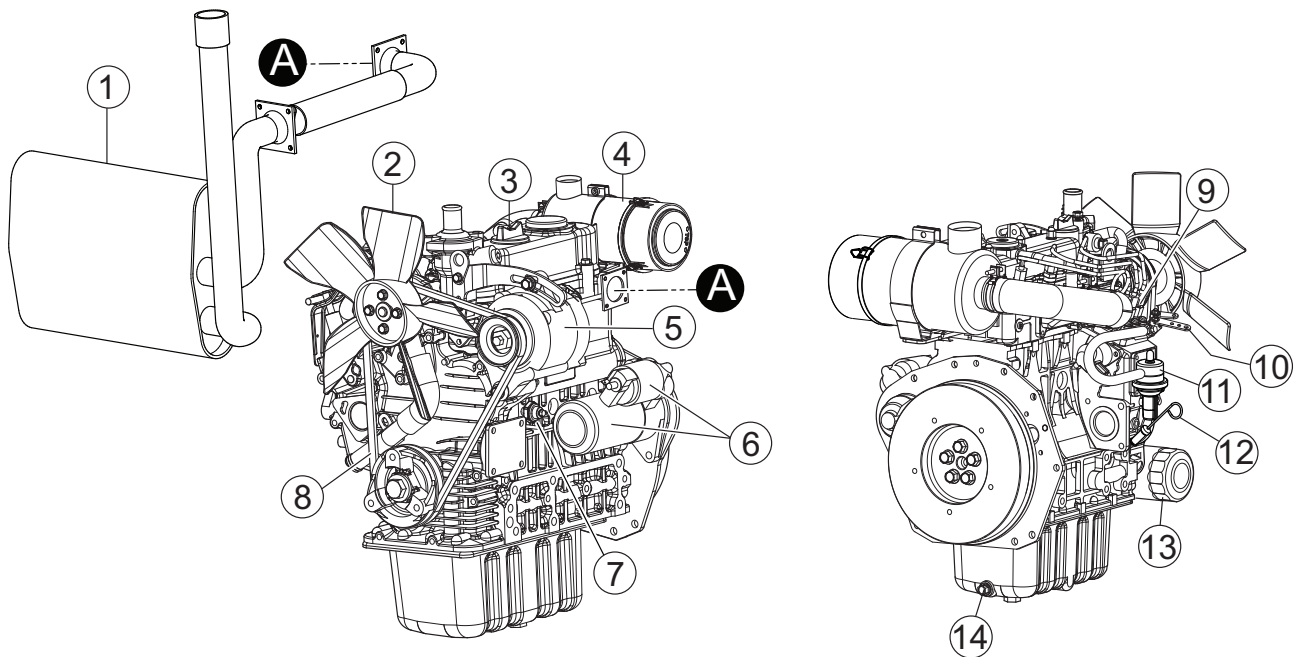

Figure 10. Kubota Z482 Diesel Engine

INITIAL SERVICING

The engine (Figure 10) must be checked for proper lubrication and filled with fuel prior to operation. Refer to the manufacturer's engine manual for instructions and details of operation and servicing.

1. **Muffler** — Used to reduce noise and emissions. **NEVER** touch muffler when the generator is in use. Always allow time for engine to cool before servicing.
2. **Cooling Fan Blades** — Make sure cooling fan blades are not bent or broken. A damaged fan blade can cause the engine to run hot and overheat.
3. **Oil Filler Cap** — Remove this cap to add oil. Fill with recommended type oil as listed in Table 6.
4. **Air Filter** — Prevents dirt and other debris from entering the air intake system. Loosen clips on side of air filter canister to gain access to filter element. Replace with manufacturer's recommended type air cleaner only.
5. **Alternator** — Provides power to the +12VDC electrical system. Replace with only manufacturer's recommended type alternator.
6. **Starter** — Starts engine when ignition key is rotated clockwise to the "ON" position.
7. **Oil Pressure Switch** — Monitors engine oil pressure. In the event of low oil pressure engine will shutdown.
8. **V-Belt** — **ALWAYS** make sure V-belt is properly tensioned. A loose or defective V-belt can adversely affect the performance of the generator.
9. **Injector Pump** — Provides fuel under pressure to the injector nozzles.
10. **Speed Control Lever** — Controls engine speed. This lever is factory set at 3600 rpm to maintain proper voltage and frequency. **DO NOT** adjust this lever out of factory range.
11. **Fuel Feed Pump** — Pumps fuel to the injection system.
12. **Oil Dip Stick/Gauge** — Remove to check amount and condition of oil in crankcase. Refill or replace with recommended type oil as listed in Table 6.
13. **Oil Filter** — Spin-on type, filters oil contaminants. Replace filter as recommended in the maintenance section of this manual.
14. **Oil Drain Plug** — Remove to drain crankcase oil. Fill with recommended type oil as listed in Table 6. Crankcase holds a maximum of 2.64 quarts (2.5 liters) of motor oil.

LOAD APPLICATIONS

SINGLE PHASE LOAD — 60 HZ

Always be sure to check the nameplate on the generators and equipment to insure the wattage, amperage and frequency requirements are satisfactorily supplied by the generators for operating the equipment.

Generally, the wattage listed on the nameplate of the equipment is its rated output. Equipment may require 130—150% more wattage than the rating on the nameplate, as the wattage is influenced by the efficiency, power factor and starting system of the equipment.

NOTICE

If wattage is not given on the equipment's name plate, approximate wattage may be determined by multiplying nameplate voltage by the nameplate amperage

$$\text{WATTS} = \text{VOLTAGE} \times \text{AMPERAGE}$$

The power factor of this generators is 1.0 See Table 4 below when connecting loads.

Table 4. Power Factor By Load

Type Of Load	Power Factor
Single-phase induction motors	0.4 - 0.75
Electric heaters, incandescent lamps	1.0
Fluorescent lamps, mercury lamps	0.4 - 0.9
Electronic devices, communication equipment	1.0
Common power tools	0.8

Table 5. Cable Selection (60 Hz, Single Phase Operation)

Current in Amperes	Load in Watts		Maximum Allowable Cable Length			
	At 100 Volts	At 200 Volts	#10 Wire	#12 Wire	#14 Wire	#16 Wire
2.5	300	600	1000 ft.	600 ft.	375 ft.	250 ft.
5	600	1200	500 ft.	300 ft.	200 ft.	125 ft.
7.5	900	1800	350 ft.	200 ft.	125 ft.	100 ft.
10	1200	2400	250 ft.	150 ft.	100 ft.	
15	1800	3600	150 ft.	100 ft.	65 ft.	
20	2400	4800	125 ft.	75 ft.	50 ft.	

CAUTION: Equipment damage can result from low voltage

NOTICE

The idle control device is operated at a minimum load capacity of 100W. If the load capacity is less than 100W, place the idle control switch in the **OFF** position.

NOTICE

When using a combination of dual receptacles, total load should not exceed the rated capacity of the generator.

NOTICE

When connecting power tools or equipment pay close attention to the required starting current capacity.

To determine the running wattage for your load, multiply the running wattage as indicated by steps 1, 2, and 3 below:

- INCANDESCENT LOADS**
 Lights, heaters and similar appliances.
 total the running wattage and multiply by 1.
 Example:
 29 light bulbs @ 100W each = 2.9 kW
 use a 3 kW generator.
- SMALL MOTORS**
 Drills and other small power tools.
 Total the running wattage and multiply by 2.
 Example:
 A 1 inch drill runs at 1 kW
 use a 2 kW generator
- LARGE MOTORS**
 Submersible pumps, table saws etc.
 Total the running wattage and multiply by 3.
 Example:
 A conveyor belt runs at 8 kW
 use a 24 kW generator.

NOTICE

Motors and motor-driven equipment draw much greater current for starting than during operation. Always use an adequate size extension cable which can carry the required load.

EXTENSION CABLES

When electric power is to be provided to various tools or loads at some distance from the generator, extension cords are normally used. **Cables should be sized to allow for distance in length and amperage so that the voltage drop between the generator and point of use (load) is held to a minimum.** Use the cable selection chart (Table 5) as a guide for selecting proper cable size.

GENERAL INSPECTION PRIOR TO OPERATION

Power Tools (Grounding)

When using power tools or electrical equipment requiring AC power from the generator, make sure power tool cord has a ground pin or is double insulated as shown in Figure 11.

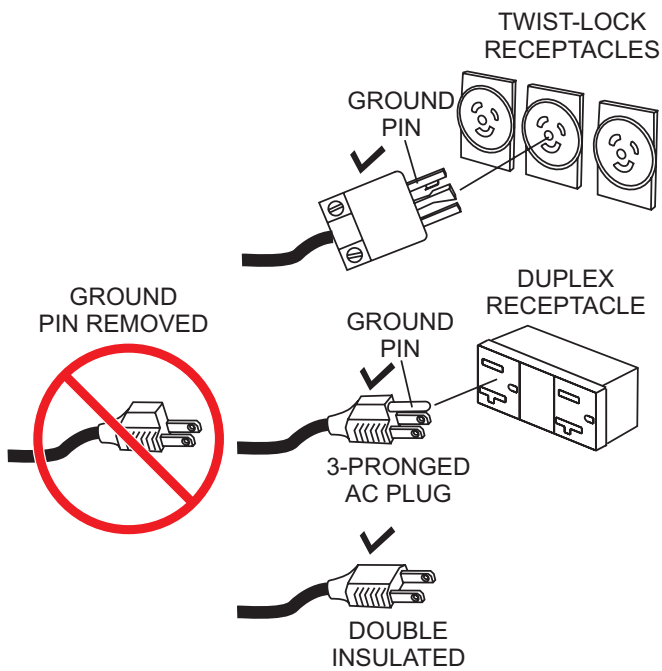

Figure 11. Ground Pin

NOTICE

Double-insulated power tools and small appliances have specially insulated housings that eliminate the need for a ground. These types of double-insulated power cords are designed so that no part of the device will be electrically live even if the internal insulation fails.

CIRCUIT BREAKERS

ALWAYS place the *main*, and *aux* circuit breakers in the **OFF** position prior to starting the engine.

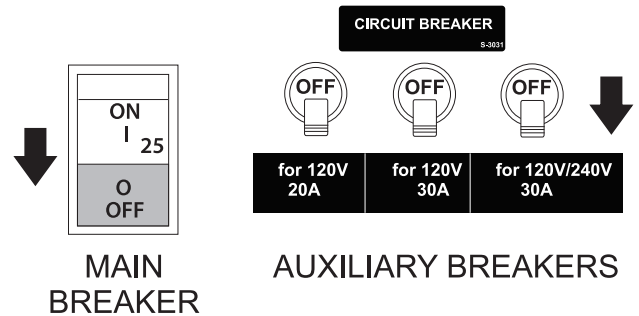

Figure 12. Main/Aux. Breakers OFF

BEFORE STARTING

1. Read safety instructions at the beginning of manual.
2. Clean the generator, removing dirt and dust, particularly the engine cooling air inlet. Caution must be taken to ensure generator is 100% dry before use.
3. Check the air filter for dirt and dust. If air filter is dirty, replace air filter with a new one as required.
4. Check fastening nuts and bolts for tightness

ENGINE OIL CHECK

NOTICE

This **KUBOTA** engine is equipped with a low oil shutdown capability. A built-in sensor will automatically turn off the engine should the oil level fall below a safe operating condition. Make sure the generator is placed on level ground. Placing the generator on level ground will ensure that the low oil sensor will function properly.

1. To check the engine oil level, place the generator on secure level ground with the engine stopped.
2. Remove the dipstick from its holder (Figure 13) and wipe clean.

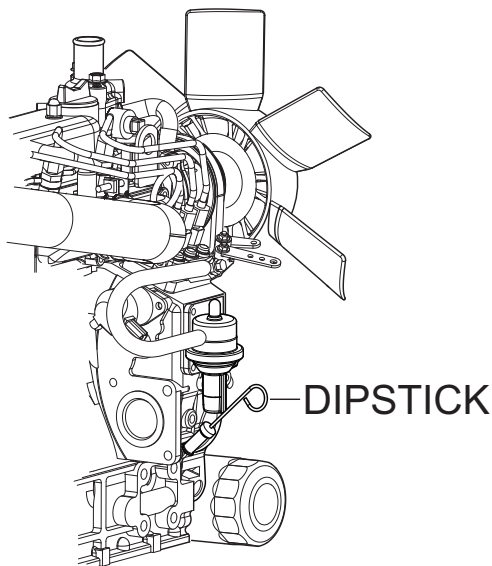

Figure 13. Engine Oil Dipstick Removal

3. Re-Insert dipstick, then remove dipstick from its holder. Check the oil level shown on the dipstick Figure 14.

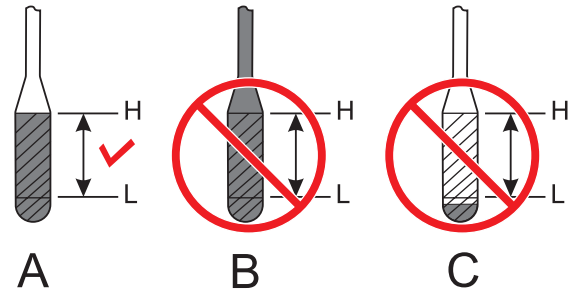

Figure 14. Engine Oil Dipstick

4. Verify that the engine oil level is maintained between the **H** and **L** markings on the dipstick as referenced in Figure 14A.
5. If the engine oil level is low (Figure 14C), remove the oil filler cap (Figure 15) and fill to a safe operating level (max) as indicated by the dipstick (Figure 14A).

NOTICE

When adding engine oil **DO NOT** overfill (Figure 14B).

6. Fill with recommended type oil as listed in Table 6. Maximum oil capacity is 2.64 quarts (2.5 liters).

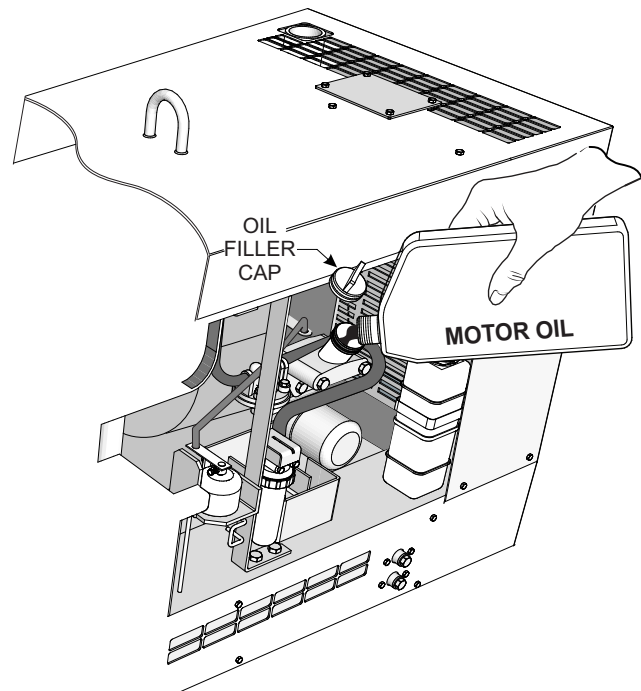

Figure 15. Engine Oil Filler Port

Table 6. Oil Type

Temperature	Oil Type
Above 77° F (25° C)	SAE 30 or SAE10W-30 SAE 15W-40
32° ~ 77° F (0° ~ 25° C)	SAE 20 or SAE10W-30 SAE 15W-40
Below 32° F (0° C)	SAE 10 or SAE10W-30 SAE 15W-40

FUEL CHECK

NOTICE

When refueling, be sure to use a strainer for filtration. **DO NOT** top-off fuel. **DO NOT** fill the tank beyond capacity. Wipe up any spilled fuel immediately!

Fill the fuel tank with #2 diesel fuel. **DO NOT** fill the tank beyond capacity.

Pay attention to the fuel tank capacity when replenishing fuel. Refer to the fuel tank capacity listed in Table 2.

The fuel tank cap must be closed tightly after filling. Handle fuel in a safety container. If the container does not have a spout, use a funnel.

1. Read the fuel gauge located on top of the generator (Figure 16) to determine if the fuel level is low.

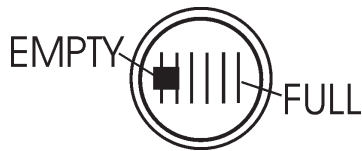

Figure 16. Fuel Gauge

2. If fuel is low, remove the fuel cap (Figure 17) located on top of the generator and replenish with clean #2 diesel fuel.

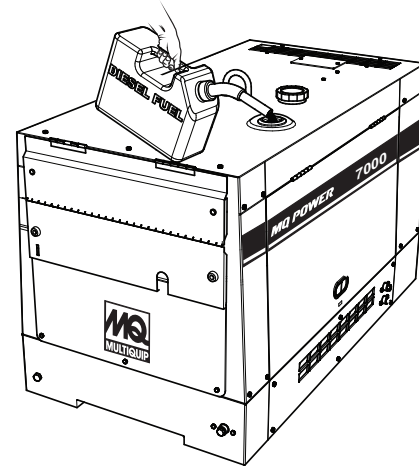

Figure 17. Adding Fuel

! DANGER



Motor fuels are highly flammable and can be dangerous if mishandled. **DO NOT** smoke while refueling. **DO NOT** attempt to refuel the generator if the engine is hot!, running or in the dark.

COOLANT (ANTIFREEZE)

Kubota recommends Antifreeze/Summer Coolant for use in their engines, which can be purchased in concentrate (and mixed with 50% demineralized water) or pre-diluted. See the Kubota Engine Owner's Manual for further details.

! WARNING



If adding coolant/antifreeze mix to the radiator, **DO NOT** remove the radiator cap until the unit has completely cooled. The possibility of hot coolant exists which can cause severe burns.

Day-to-day addition of coolant is done from the recovery tank Figure 18. When adding coolant to the radiator, **DO NOT** remove the radiator cap until the unit has completely cooled. See Table 7 for engine, radiator, and recovery tank coolant capacities. Make sure the coolant level in the recovery tank is always between the "FULL" and "LOW" markings.

NOTICE

Normally, only the coolant level in the recovery tank needs to be checked. However, the radiator cap should be opened once a week to verify that coolant is visible (full) in the radiator.

Table 7. Coolant Capacity

Engine and Radiator	.74 gal (2.8 liters)
Reserve Tank (Full)	.23 gal (.87 liters)

1. Verify that the coolant level in the coolant recovery tank is between the **FULL** and **LOW** markings as shown in Figure 18.

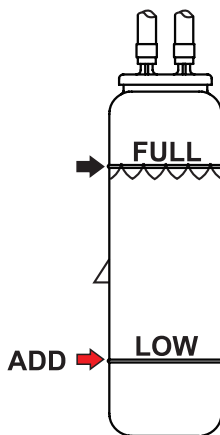

Figure 18. Coolant Recovery Tank

Operation Freezing Weather

When operating in freezing weather, be certain the proper amount of antifreeze (Table 8) has been added.

Table 8. Anti-Freeze Operating Temperatures

Vol % Anti-Freeze	Freezing Point	
	°C	°F
50	-37	-34

NOTICE

When the antifreeze is mixed with water, the antifreeze mixing ratio must be less than 50%.

CLEANING THE RADIATOR

The engine may overheat if the radiator fins become overloaded with dust or debris. Periodically clean the radiator fins with compressed air. Cleaning inside the machine is dangerous, so clean only with the engine turned off and the **negative** battery terminal disconnected.

AIR CLEANER

Periodic cleaning/replacement is necessary. Inspect it in accordance with the KUBOTA Engine Owner's Manual.

FAN BELT TENSION

A slack fan belt may contribute to overheating, or to insufficient charging of the battery. Inspect the fan belt for damage and wear and adjust it in accordance with the Kubota Engine Owner's Manual.

The fan belt tension is proper if the fan belt bends 10 to 15 mm (Figure 19) when depressed with the thumb as shown below.

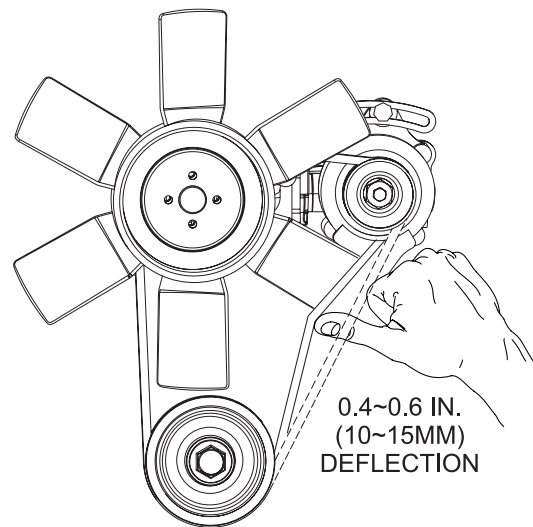

Figure 19. Fan Belt Tension

CAUTION



NEVER place hands near the belts or fan while the generator set is running.

BATTERY

This unit is of negative ground **DO NOT** connect in reverse. Always maintain battery fluid level between the specified marks. Battery life will be shortened, if the fluid level are not properly maintained. Add only distilled water when replenishment is necessary.

DO NOT over fill. Check to see whether the battery cables are loose. Poor contact may result in poor starting or malfunctions. **Always** keep the terminals firmly tightened. Coating the terminals with an approved battery terminal treatment compound. Replace battery with only recommended type battery.

The battery is sufficiently charged if the specific gravity of the battery fluid is 1.28 (at 68° F). If the specific gravity should fall to 1.245 or lower, it indicates that the battery is dead and needs to be recharged or replaced.

Before charging the battery with an external electric source, be sure to disconnect the battery cables.

BATTERY CABLE INSTALLATION

ALWAYS be sure the battery cables (Figure 20) are properly connected to the battery terminals as shown below. The **red cable** is connected to the positive terminal of the battery, and the **black cable** is connected to the negative terminal of the battery.

CAUTION

ALWAYS disconnect the negative terminal **FIRST** and reconnect negative terminal **LAST**.

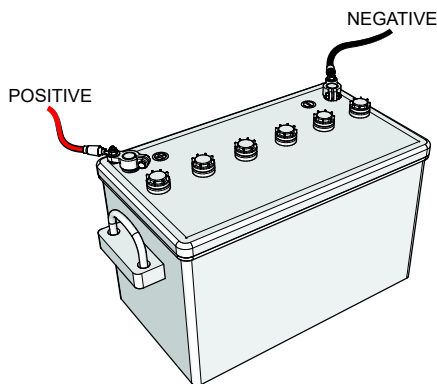

Figure 20. Battery Connections

When connecting battery do the following:

1. **NEVER** connect the battery cables to the battery terminals when the **Ignition Switch** is in the **START** position. **ALWAYS** make sure that the **Ignition Switch** is in the **OFF** position when connecting the battery.
2. Place a small amount of battery terminal treatment compound around both battery terminals. This will ensure a good connection and will help prevent corrosion around the battery terminals.

NOTICE

If the battery cable is connected incorrectly, electrical damage to the generator will occur. Pay close attention to the polarity of the battery when connecting the battery.

CAUTION

Inadequate battery connections may cause poor starting of the generator, and create other malfunctions.

ALTERNATOR

The polarity of the alternator is negative grounding type. When an inverted circuit connection takes place, the circuit will be in short circuit instantaneously resulting the alternator failure.

DO NOT put water directly on the alternator. Entry of water into the alternator can cause corrosion and damage the alternator.

WIRING

Inspect the entire generator for bad or worn electrical wiring or connections. If any wiring or connections are exposed (insulation missing) replace wiring immediately.

PIPING AND HOSE CONNECTION

Inspect all piping, oil hose, and fuel hose connections for wear and tightness. Tighten all hose clamps and check hoses for leaks.

If any hose (**fuel or oil**) lines are defective replace them immediately.

BEFORE STARTING THE ENGINE

CAUTION

The engine's exhaust contains harmful emissions. **ALWAYS** have adequate ventilation when operating. Direct exhaust away from nearby personnel.

NOTICE

The DA7000SSA3 generator is equipped with a GFCI sensing module. The purpose of this module is to sense a ground fault during operation of the generator and open the main breaker once the ground fault has been detected.

Multiquip recommends that the GFCI sensing module be tested before each use of the generator. Refer to the maintenance section of this manual for testing of the GFCI sensing module.

1. Open the cabinet door and turn the fuel cock lever (Figure 21) to the "ON" position.

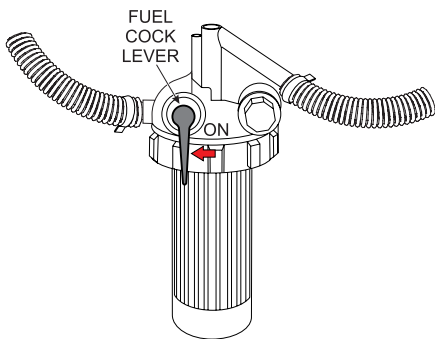

Figure 21. Fuel Cock Lever (ON)

2. **NEVER** operate the generator with the doors *open* (Figure 22). Operation with the doors open may cause insufficient cooling of the unit, and engine damage may result. Close the doors for normal operation.

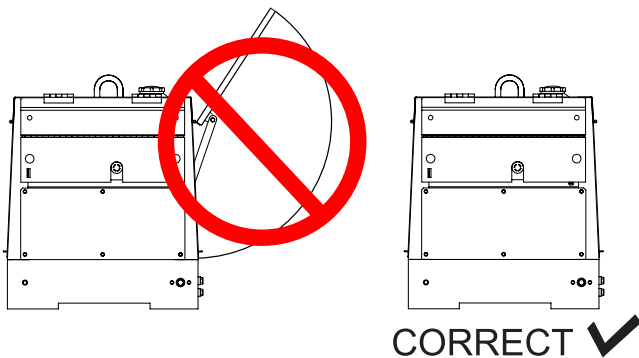

Figure 22. Generator Doors

3. **NEVER** start the engine with the main circuit breaker in the **ON** position. Always place circuit breaker (Figure 23) in the **OFF** position before starting.

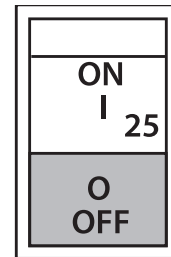

Figure 23. Main Circuit Breaker (OFF)

4. **NEVER** start the engine with the auxiliary circuit breakers in the **ON** position. Always place circuit breakers (Figure 24) in the **OFF** position before starting the engine.

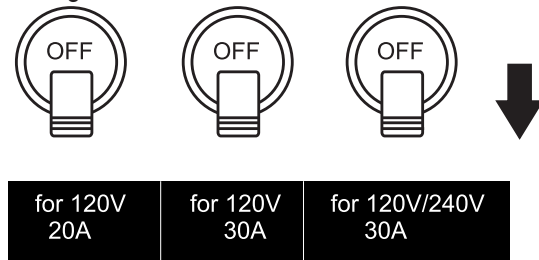

Figure 24. Auxiliary Circuit Breakers (OFF)

STARTING THE ENGINE

1. Insert the key into the starter switch (Figure 25) and turn it to the "RUN" position..

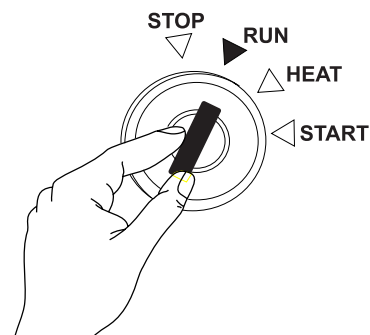

Figure 25. Starter Switch (RUN)

- Verify that the oil pressure, temperature, charge and glow plug lamps on the " Engine Warning Lamp Unit Display" are lit. If either lamp is not lit, check the system and wiring (refer to the Engine Operation Manual)

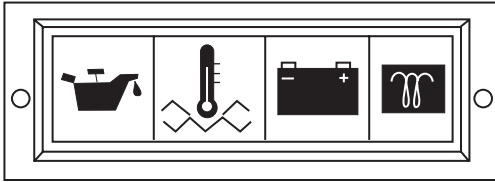

Figure 26. Engine Warning Lamp Unit (ON)

- Turn the ignition key to the **HEAT** position. When the preheat light goes off, turn the key to the **START** position to start the engine. As soon as the engine starts, release the key. The key will automatically return to the **RUN** position.
- In cold weather conditions, it may be required to extend the duration of the **HEAT** position for proper starting.
- If the engine does not start within 10 seconds after the key is turned to the **START** position, wait for about 30 seconds and repeat the procedure as described in steps 1-3.
- When the engine starts, the oil pressure light and charge light should go out. If these lights stay on, immediately stop the engine and check the system and wiring (refer to the Engine Operation Manual).
- Let the engine idle for five minutes with the **Idle Control Switch** (Figure 27) placed in the **ON** position.



Figure 27. Idle Control Switch (ON)

NOTICE

Placing the idle control switch (Figure 27) in the **OFF** position allows the engine to operate at a maximum speed of about 3600 RPM's.

When the idle control switch is placed in the up position (**ON**), the generator will run at idle speed (2200 RPM's) until a load is applied, at that time the engine speed will increase to 3600 RPM's as long as a load is being applied.

When the load is not in use, the engine speed will drop back to the idle mode after about 3 seconds.

OUTPUT VOLTAGE VERIFICATION

- Place **main** circuit breaker (Figure 28) in the **ON** position.

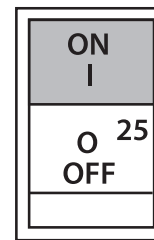

Figure 28. Main Circuit Breaker (ON)

- Place auxiliary circuit breakers (Figure 29) in the **ON** position.

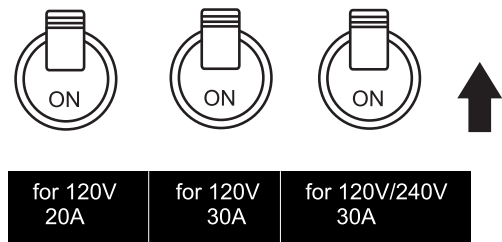

Figure 29. Auxiliary Circuit Breakers (ON)

- Read the voltmeter on front panel of generator (Figure 30) and verify that 120 VAC is displayed. Using an external voltmeter as shown in Figure 30, verify that 120 VAC is present at the 120V twist-lock and duplex receptacles.

OPERATION/SHUTDOWN

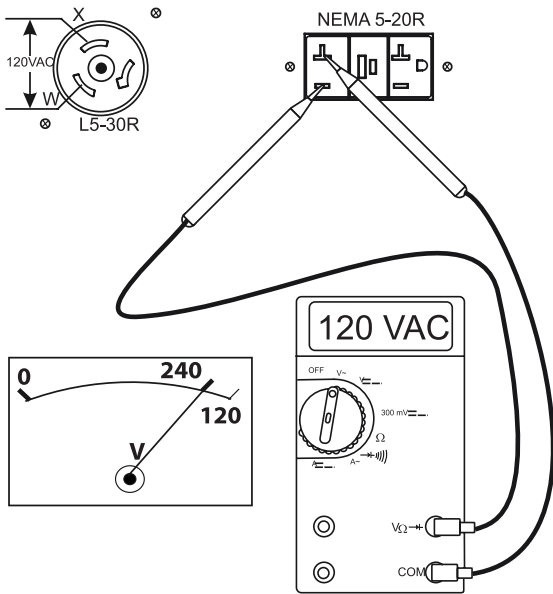

Figure 30. 120V GFCI/L5-30R Receptacles

NOTICE

When using a combination of dual receptacles, total load should not exceed the rated capacity of the generator.

- The CS-6369 receptacle is a dual voltage receptacle (120/240 volts). Using an external voltmeter as shown in Figure 31, verify that 120/240 VAC is present at the CS-6369 twist-lock receptacle.

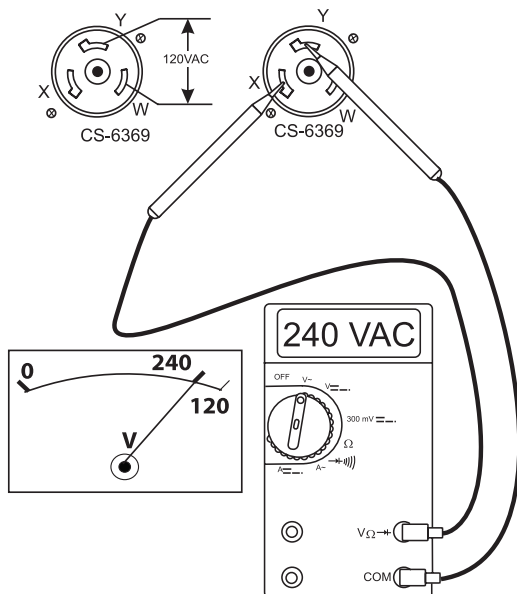

Figure 31. 120/240 CS-6369 Receptacle

- The L14-30R receptacle is a dual voltage receptacle (120/240 volts). Using an external voltmeter as shown in Figure 32, verify that 120/240 VAC is present at the L14-30R twist-lock receptacle.

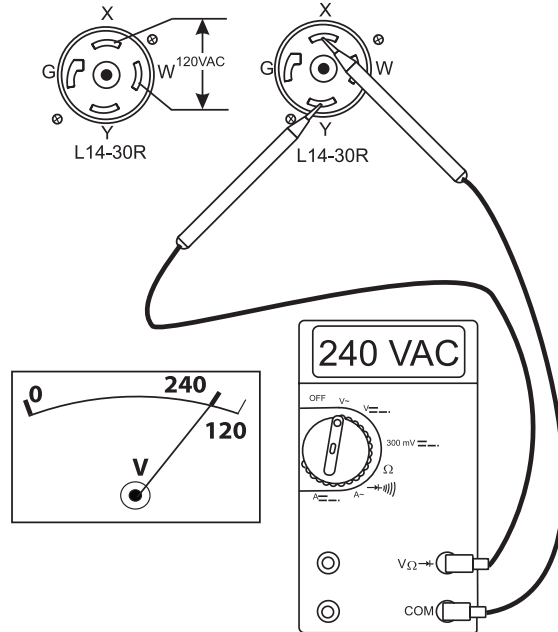

Figure 32. 120/240V L14-30R Receptacle

- Connecting of loads (power tools, lighting ect.) to the generator receptacles can now be done.

Stopping the Engine (Normal Shutdown)

1. Place **main** circuit breaker (Figure 33) in the **OFF** position.

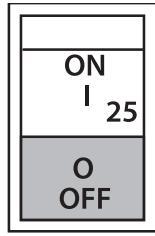

Figure 33. Main Circuit Breaker (OFF)

2. Place auxiliary circuit breakers (Figure 34) in the **OFF** position.

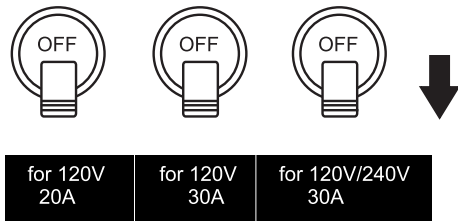

Figure 34. Auxiliary Circuit Breakers (OFF)

3. Place idle control switch switch (Figure 35) in the **ON** position.

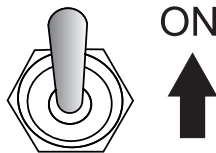

Figure 35. Idle Control switch (ON)

4. Let engine run at idle with no load for 3-5 minutes.
5. Place the starter switch key (Figure 36) in the **STOP** position and remove the key.

6.

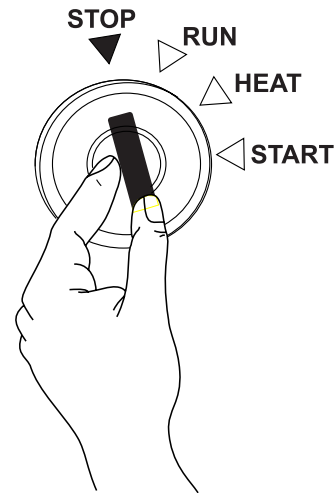

Figure 36. Starter Switch (Stop Position)

7. Place fuel cock lever (Figure 37) in the **OFF** position.

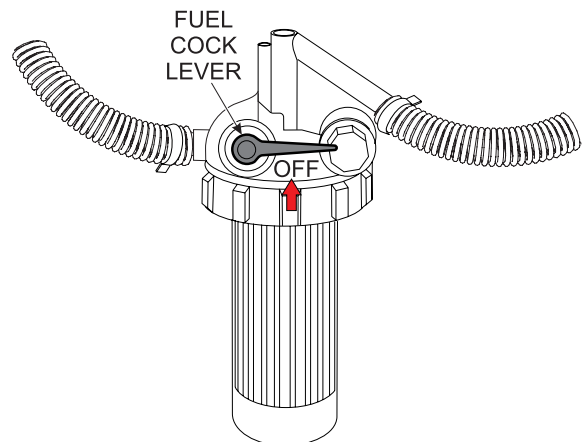

Figure 37. Fuel Cock Lever (OFF)

8. Remove all load connections from the generator.

Emergency Shutdown

1. Place starter switch key (Figure 25) in **STOP** position. Remove key. Place fuel cock lever (Figure 37) in the **OFF** position.

PREPARATION FOR LONG TERM STORAGE

Generator Storage

For storage of the generating set for over 30 days, the following is required:

- Run the engine until all the fuel is completely consumed.
- Drain the fuel tank completely, or add STA-BIL to the fuel
- Completely drain the oil from the crankcase and refill with fresh oil.
- Disconnect the **negative battery cable** from the battery.
- Clean all external parts of the generating set with a cloth.
- If generator is mounted on a trailer, jack trailer up and place on blocks so tires do not touch the ground or block and completely remove the tires.
- Cover the generating set and store in a clean, dry place

MAINTENANCE

Use Table 9 as a general maintenance guideline when servicing your engine. For more detail engine maintenance information, refer to the engine owner's manual supplied with your engine.

Table 9. Engine Maintenance Schedule									
DESCRIPTION (3)	OPERATION	DAILY	FIRST MONTH OR 50 HRS.	EVERY 3 MONTHS OR 25 HRS.	EVERY 6 MONTHS OR 50 HRS.	EVERY YEAR OR 100 HRS.	EVERY 2 YEARS OR 200 HRS.	EVERY 8 YEARS OR 800 HRS.	
Engine Oil	CHECK	X							
	CHANGE		X			X			
Oil Filter Cartridge	CHANGE		X			X	X		
Air Cleaner Element	CHECK	X			X				
	CHANGE				X (1)	X			
All Nuts & Bolts	RETIGHTEN IF NECESSARY	X							
Cooling Fins	CHECK				X				
Fuel Tank	CLEAN						X		
Fuel Filter	CLEAN						X	X	
Fuel Filter Element	CHANGE		X				X		
Fuel lines	CHANGE	Every 2 years, replace if necessary (2)							
Battery	CHANGE						X		
Radiator Hoses/ Clamps	CHANGE	Every 2 years, replace if necessary (2)							
Radiator Coolant	CHANGE						X		
Idle Speed	CHECK-ADJUST					X (2)			
Valve Clearance	CHECK-ADJUST							X (2)	
Fan Belt	CHECK TIGHTNESS					X			
WATER SEPARATOR	DRAIN					X			

(1) Service more frequently when used in **DUSTY** areas.

(2) These items should be serviced by your service dealer, unless you have the proper tools and are mechanically proficient. Refer to the KUBOTA Shop Manual for service procedures.

(3) For commercial use, log hours of operation to determine proper maintenance intervals.

NOTICE

Thoroughly remove dirt and oil from the engine and control area. Clean or replace the air cleaner elements as necessary. Check and retighten all fasteners as necessary.

AIR CLEANER

This is a dry type filter. **NEVER** apply oil to it. If generator is used in severe dusty areas service air cleaner element more frequently.

NOTICE

If the engine is operating in very **dusty** or **dry** grass conditions, a clogged air cleaner will result. This can lead to a loss of power, excessive carbon buildup in the combustion chamber and high fuel consumption. Change air cleaner more **frequently** if these conditions exist.

Every 250 hours: Remove air cleaner element (Figure 38) and clean the heavy duty paper element with light spray of compressed air. Replace the air cleaner as needed.

This Kubota diesel engine is equipped with a replaceable, high-density paper air cleaner element.

Primary Air Cleaner Elements

CAUTION



Wear protective equipment such as approved safety glasses or face shields and dust masks or respirators when cleaning air filters with compressed air.

1. Release the latches (Figure 38) that secures the cover to the air cleaner body.
2. Remove the air cleaner cover and set aside.
3. Remove both the primary air cleaner element.
4. Check the air cleaner daily or before starting the engine
5. Check for and correct heavy buildup of dirt and debris along with loose or damaged components.

NOTICE

Operating the engine with loose or damaged air cleaner components could allow unfiltered air into the engine causing premature wear and failure.

6. To clean the primary element (paper air filter) as referenced in (Figure 38), tap the filter element several times on a hard surface to remove dirt, or blow compressed air (not to exceed 30 psi (207 kPa, 2.1 kgf/cm²) through the filter element from the inside out.

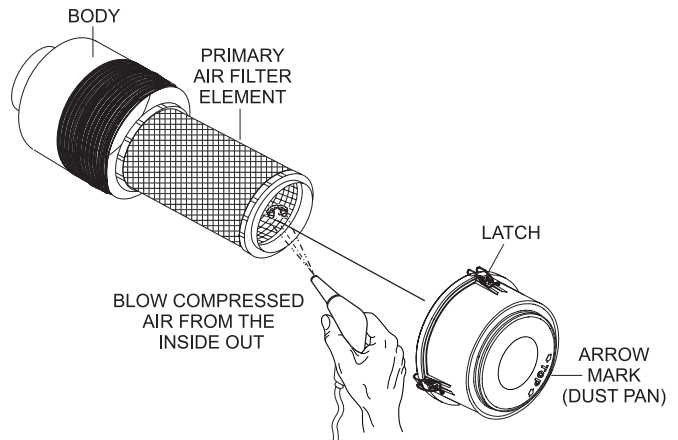

Figure 38. Air Cleaner

7. Replace primary air filter elements if it is damaged or excessively dirty.
8. Clean the inside of the air cleaner body.
9. Reinstall the primary air filter element back into air cleaner body.
10. Reinstall the air cleaner cover, and secure with latches.

NOTICE

DO NOT run the engine with the air cleaner removed or without an element.

ENGINE OIL

Every 100 hours: Change engine oil after the first 50 hours of operation and 100 hours thereafter. Always check the crankcase oil level prior to each use, or when the fuel tank is filled. Insufficient oil may cause severe engine damage. Make sure generator is level when checking oil level. The oil level must be between the two notches on the dipstick as shown in Figure 14.

1. Remove engine oil drain plug located at the bottom of the generator enclosure (Figure 39) and drain oil from crankcase. For best results drain oil while engine is warm. Reinstall oil drain plug, and add engine oil as specified in Table 6. Crankcase oil capacity is 2.64 qts. (2.5 liters).

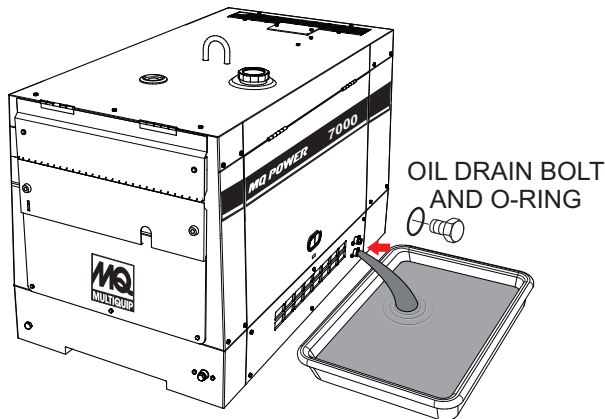

Figure 39. Engine Oil Drain Plug

Oil Filter Cartridge

Every 200 hours: Replace the engine oil filter cartridge after every 200 hours of operation.

1. Clean the area around the lubricating oil filter head.
2. Coat oil filter seal (Figure 40) with clean engine oil.
3. Install new oil filter first by hand until it makes contact with the filter head surface. Tighten it another 3/4 turn using the filter wrench.

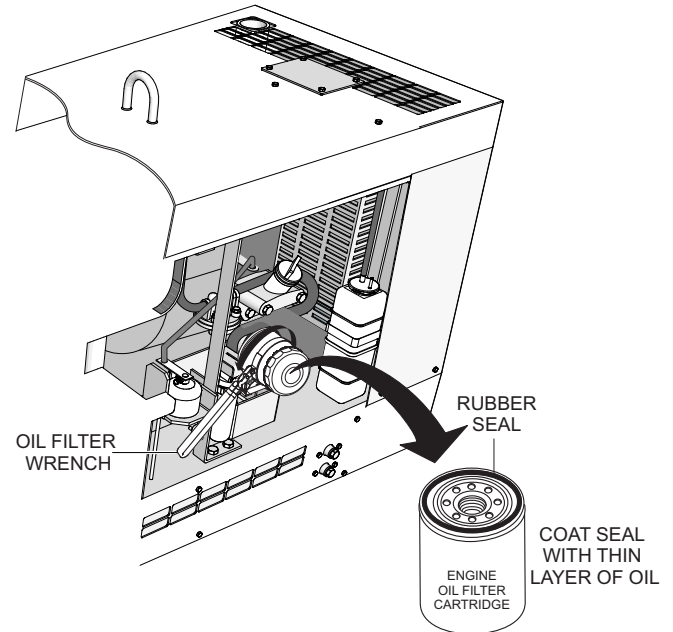

Figure 40. Oil Filter Cartridge

4. Install drain bolt with sealing washer and tighten.

NOTICE

When installing the oil filter, coat rubber seal with a small amount of lubricant (motor oil). **DO NOT** over-tighten cartridge. Hand tighten only.

5. Replace engine oil with recommended type oil as listed in Table 6. For engine oil capacity, see Table 2 (engine specifications). Fill to upper limit as shown in Figure 14.
6. Run the engine for several minutes. Watch for oil leakage. Shut the engine down and allow it to sit for several minutes. Top off the oil to the upper limit on the dipstick.

CLEANING THE FUEL FILTER

Every 100 hours: Clean fuel filter every 100 hours of operation or once a month to remove dust or water.

1. Place fuel cock lever (Figure 41) in the OFF (close) position.
2. Disconnect fuel lines from fuel filter.

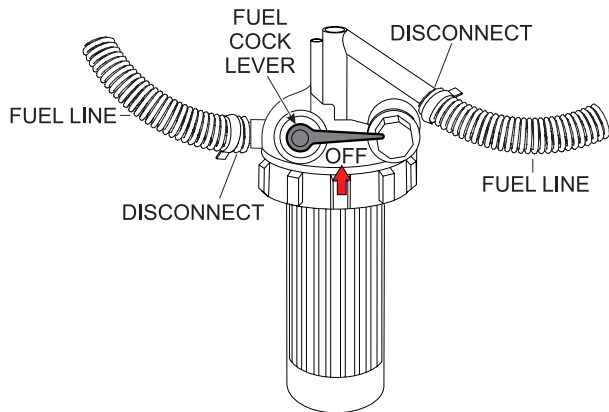

Figure 41. Fuel Cock Lever (OFF)

3. Unscrew the filter bowl (Figure 42) from the fuel filter head.

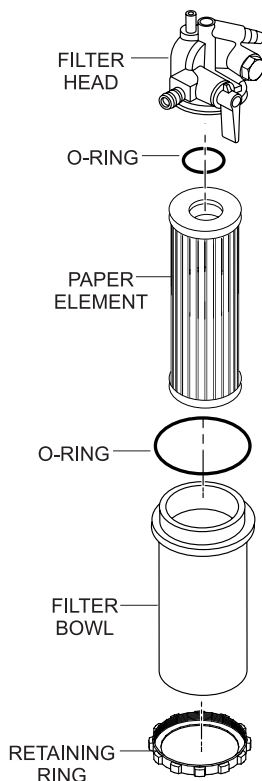

Figure 42. Fuel Filter Disassembly

4. Wipe the inside of the fuel filter bowl with a clean cloth to remove any foreign matter or debris that may have accumulated. Rinse with diesel fuel.
5. Remove fuel filter paper element, and rinse with diesel fuel.
6. Reinstall filter bowl and paper element back onto the filter head. Hand-tighten retaining ring.
7. Inspect all fuel lines every 50 hours.

REPLACING FUEL FILTER ELEMENT

First 50 And Then Every 200 hours: Replace fuel filter element.

1. Unscrew the filter bowl from the fuel filter head (Figure 42).
2. Remove fuel filter paper element and replace with a new one.
3. Replace o-ring and coat with a small amount of clean 15W-40 engine oil.
4. Insert the new fuel filter element into the filter bowl.
5. Reinstall filter bowl first by hand until it makes contact with the fuel filter head surface. Hand-tighten only.
6. Remove the air from the fuel system. Reference the Kubota Operation and Maintenance Manual, "Bleeding the Fuel System".

AUTOMATIC AIR BLEEDING DEVICE

When the engine stops due to running out of fuel, take off the fuel filter or fuel piping and re-start the machine in accordance with the following instructions.

1. Refuel the fuel tank and place the fuel cock lever in the **OPEN** position.
2. Place the starter switch key in the **START** position. When the engine starter engages, the automatic air vent device will expel the air inside the fuel system.
3. After 10 to 20 seconds of turning the engine over, the automatic air vent device would have expelled all the air out of the fuel system. At this point, the engine will be able to start.

NOTICE

If air enters the fuel injection system of a diesel engine, starting becomes impossible. After running out of fuel, or after disassembling the fuel system, bleed the system. Reference the **Kubota Operation and Maintenance Manual** for details.

STOPPING ENGINE (STARTER SWITCH FAILURE)

In the event the engine continues to run even after the starter switch has been placed in the **STOP** position, following the procedure on the next column to turn off the engine.

1. Place fuel cock lever (Figure 41) in the **CLOSED** position.
2. Place engine stop lever (Figure 43) in the **STOP** position. Continue pushing stop lever until the engine has completely stopped.

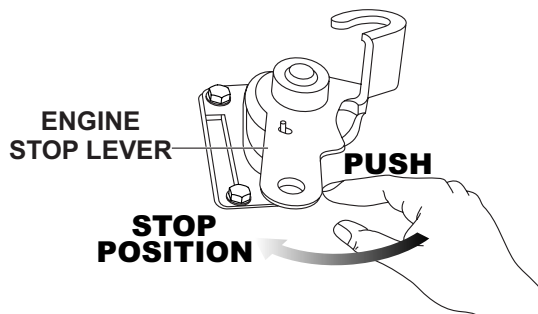

Figure 43. Engine Stop Lever

REMOVING WATER FROM THE FUEL TANK

1. After prolonged use, water and other impurities accumulate in the bottom of the tank. Occasionally inspect the fuel tank for water contamination.
2. If water contamination is present within the fuel tank, remove the fuel tank drain bolt and o-ring (Figure 44), then allow the fuel to drain into a suitable container.

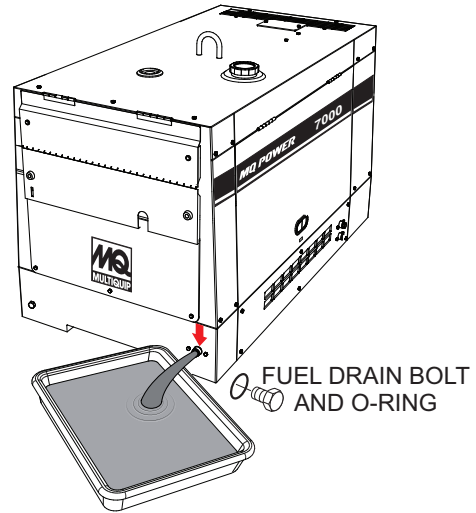

Figure 44. Draining Fuel Tank

3. During cold weather, the more empty volume inside the tank, the easier it is for water to condense. This can be reduced by keeping the tank full with diesel fuel.

CLEANING INSIDE THE FUEL TANK

1. If necessary, drain the fuel inside the fuel tank completely. Using a spray washer (Figure 45) wash out any deposits or debris that have accumulated inside the fuel tank.



Figure 45. Fuel Tank Cleaning

2. Reinstall fuel tank drain bolt with o-ring and tighten.

FUEL TANK INSPECTION

In addition to cleaning the fuel tank, the following components should be inspected for wear:

- **Fuel Hoses** — inspect nylon and rubber hoses for signs of wear, deterioration and hardening.
- **Fuel Tank Lining** — inspect the fuel tank lining for signs of excessive amounts of oil or other foreign matter.

DRAINING ENGINE COOLANT

WARNING

DO NOT remove the pressure cap from the radiator when the engine is hot! Wait until the coolant temperature is below 120°F (50°C) before removing pressure cap.

Heated coolant spray or steam can cause severe scalding and personal injury.

1. Remove the radiator pressure cap (Figure 46) only if the coolant temperature is below 120°F (50°C).

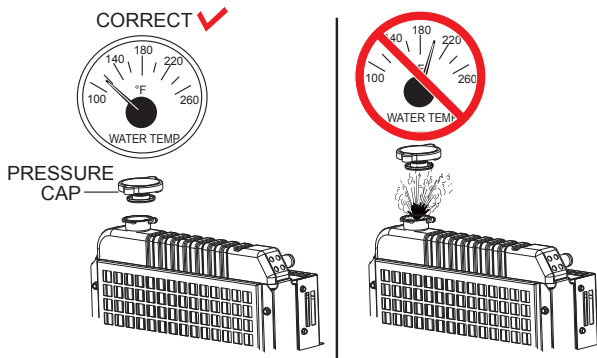

Figure 46. Radiator Pressure Cap Removal

2. Remove the coolant drain bolt and o-ring (Figure 47), then allow the coolant to drain into a suitable container.

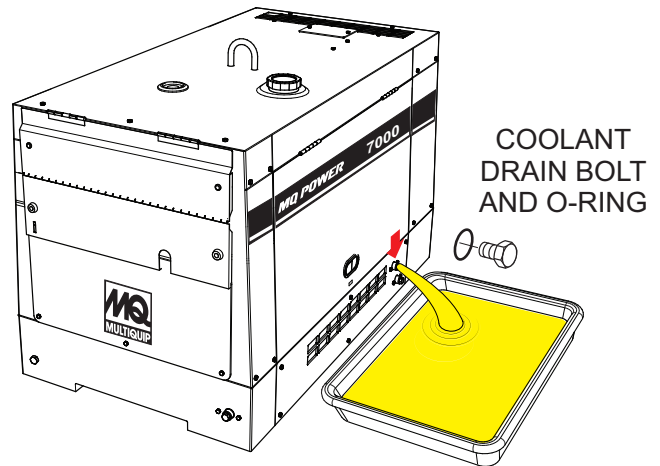

Figure 47. Coolant Drain Plug

V-BELT

Visually examine the V-belt (Figure 48) and determine if it is full of tiny cracks, frayed, has pieces of rubber missing, is peeling or otherwise damaged.

Also, examine the belt and determine if it is **oil soaked** or **"glazed"** (hard shiny appearance on the sides of the belt). Either of these two conditions can cause the belt to run hot, which can weaken it and increase the danger of it breaking.

If the V-belt exhibits any of the above wear conditions replace the V-belt immediately.

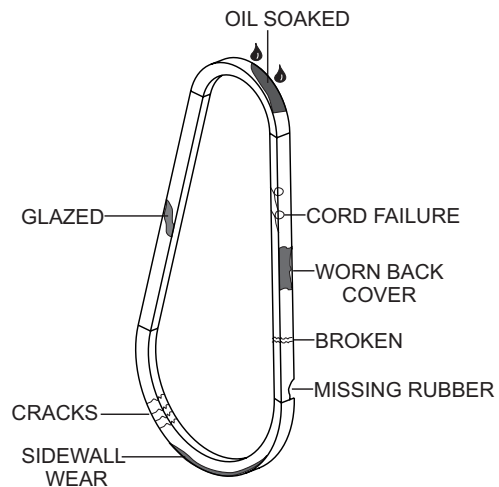

Figure 48. V-Belt Inspection

TESTING THE GFCI SENSING MODULE

If tripping of the *main* circuit breaker persists after a load is replaced with a known good one (no short circuit), perform this test with no load.

1. Start the welder-generator as outlined in the start up procedure in this manual.
2. Place the main circuit breaker, CB1 (Figure 49) in the **ON** position.

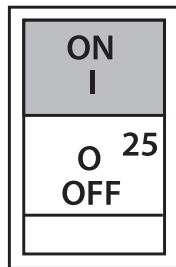

Figure 49. Main Circuit Breaker ON (GFCI Test)

3. On the GFCI sensing module, verify that the green power LED is ON (Figure 50).

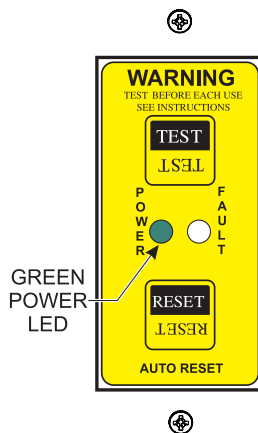

Figure 50. GFCI Sensing Module (Green LED ON)

4. Verify that the AC voltmeter is registering a voltage reading as shown in Figure 51.

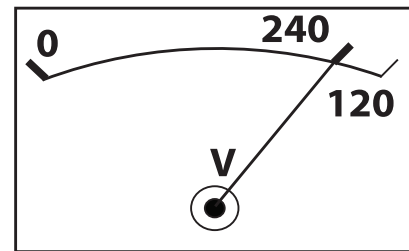

Figure 51. AC Voltmeter (Normal)

5. Next, press the **TEST** button on the GFCI sensing module (Figure 52) and verify that the *green* POWER LED turns **OFF** and the *red* FAULT LED turns **ON**.

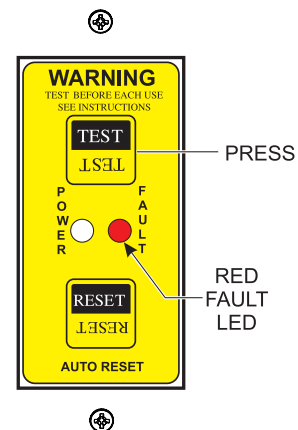

Figure 52. GFCI Module (Red/Fault LED ON)

6. Also verify that the main circuit breaker (Figure 53) switch trips to the **OFF** position.

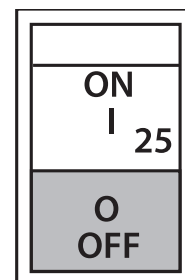

Figure 53. Circuit Breaker OFF (GFCI Test)

7. Verify that the AC voltmeter (Figure 54) on the welder-generator reads zero volts.

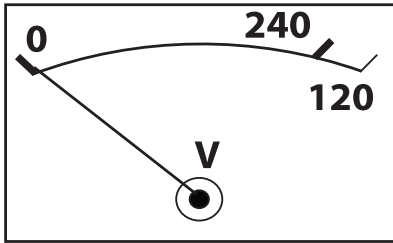

Figure 54. AC Voltmeter (Zero Volts)

8. Next, place the main circuit breaker, CB1 (Figure 55) in the **ON** position.

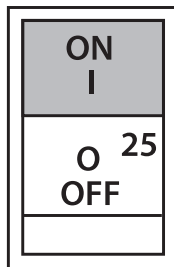

Figure 55. Main Circuit Breaker (ON)

9. To restore power, press the **RESET** button on the GFCI sensing module (Figure 56) and verify that the red fault LED turns **OFF** and the green power LED should turn **ON**.

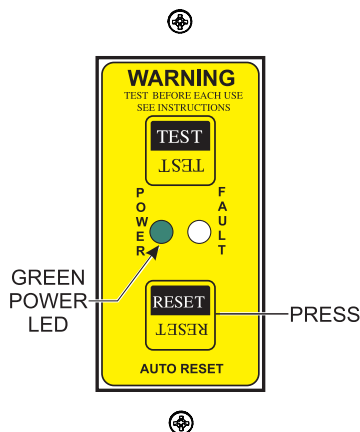

Figure 56. GFCI Sensing Module (Green LED ON Reset)

10. Verify that the AC voltmeter is registering a voltage reading as indicated by Figure 57.

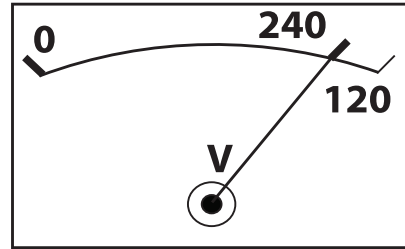

Figure 57. AC Voltmeter (120/240V)

NOTICE

It is recommended that the GFCI sensing module be tested when the generator is initially taken out of the box. Then, the generator should be tested daily at startup.

CAUTION

The GFCI module is designed to interrupt power when a ground fault exists to prevent injuries and shock hazards. **DO NOT** operate the generator if this test fails. Consult a qualified electrician for the repair or replacement of the GFCI module.

GENERATOR WIRING DIAGRAM

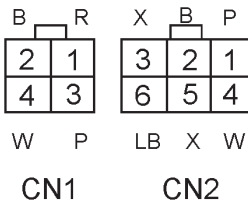
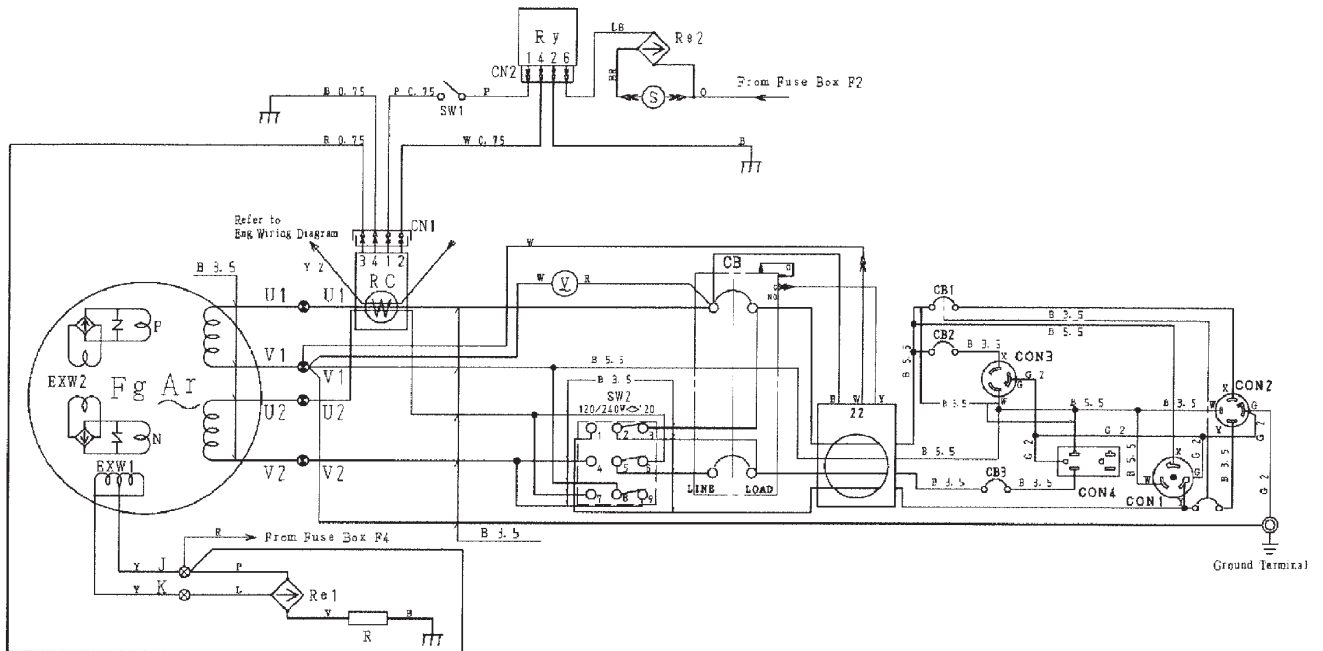

CONNECTOR
VIEWED AT
INSERTING WIRE SIDE

CODE/WIRE COLOR	
SYMBOL	COLOR
B	BLACK
L	BLUE
BR	BROWN
G	GREEN
GR	GRAY
V	VIOLET
P	PINK
R	RED
W	WHITE
Y	YELLOW
LB	LIGHT BLUE
LG	LIGHT GREEN
O	ORANGE

COMBINATION TERMINAL

TB1 ⊗ U1|V1|U2|V2

TB2 ⊗ J|K|AC|50|19|30

SYMBOL	PARTS NAME
AR	ARMATURE WINDING
Fg	FIELD WINDING
EXW1~2	EXCITATION WINDING
V	AC VOLTMETER
RE1~2	RECTIFIER
CON1	RECEPTACLE (120/240V, 50 AMP)
CON2	RECEPTACLE (120/240V, 30 AMP)
CON3	RECEPTACLE (120V, 30 AMP)
CON4	RECEPTACLE (120V, 20 AMP)
CB	MAIN CIRCUIT BREAKER (25 AMP)
CB1	CIRCUIT BREAKER (120/240, 30 AMP)
CB2	CIRCUIT BREAKER (120V, 30 AMP)
CB3	CIRCUIT BREAKER (120V, 20 AMP)
22	GFCI SENSING MODULE
SW1	IDLE CONTROL SWITCH
SW2	FULL POWER SWITCH
RC	IDLE CONTROL DEVICE
S	SOLENOID
Ry	RELAY
R	RESISTOR

ENGINE WIRING DIAGRAM

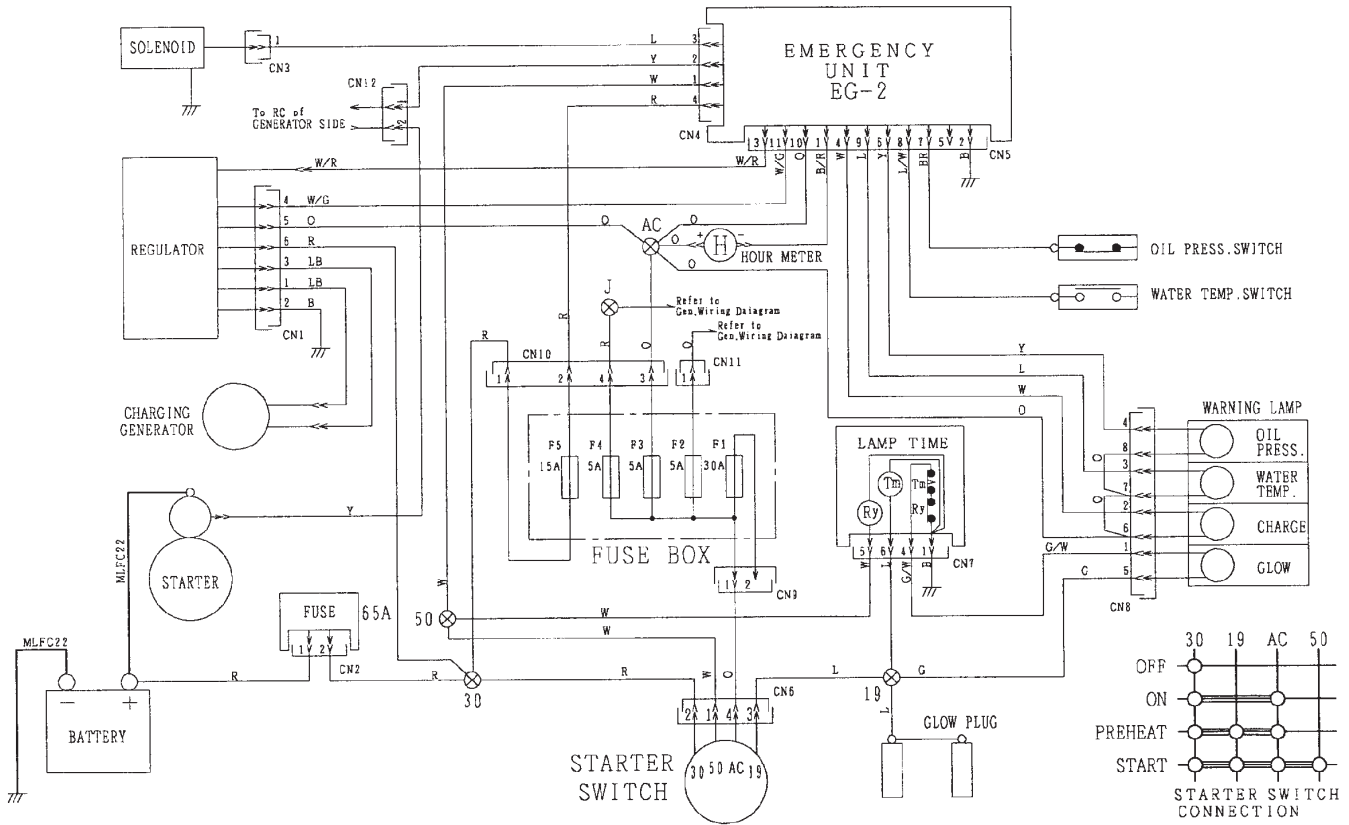

CONNECTOR VIEWED AT INSERTING WIRE SIDE

CODE/WIRE COLOR	
SYMBOL	COLOR
B	BLACK
L	BLUE
BR	BROWN
G	GREEN
GR	GRAY
V	VIOLET
P	PINK
R	RED
W	WHITE
Y	YELLOW
LB	LIGHT BLUE
LG	LIGHT GREEN
O	ORANGE

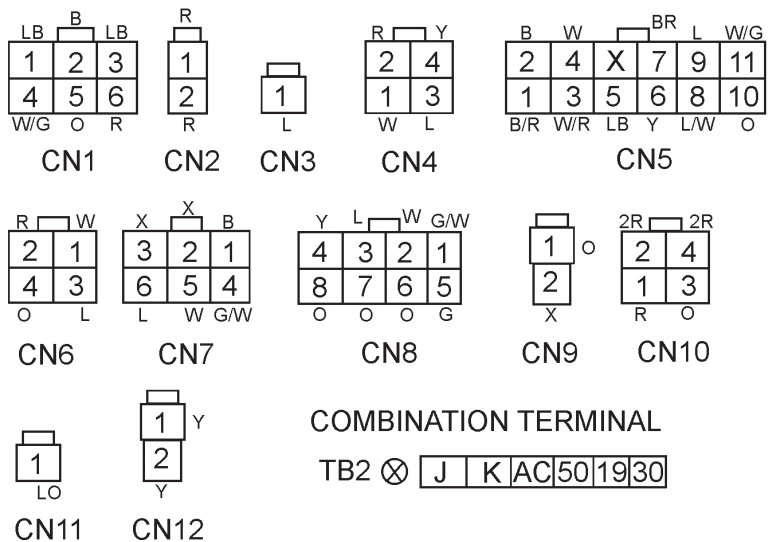

TROUBLESHOOTING (ENGINE AND GENERATOR)

Table 10. Engine and Generator Troubleshooting

SYMPTOM	POSSIBLE PROBLEM	SOLUTION
Engine fails to start and starter does not rotate.	Dead Battery?	Replace Battery.
	Defective Starter Switch?	Replace Switch.
	Defective Starter?	Replace Starter.
	Fuse F5 Burned Out?	Replace Fuse.
Engine fails to start and starter rotates.	Broken Pre-Heat Circuit?	Check Pre-Heat Circuit.
	No Fuel?	Add Fuel.
	Defective Wiring?	Check Wiring.
Engine starts "Idle Control Switch" is in OFF position and engine remains at low speed.	Defective Idle Control Switch?	Replace Switch.
	Clogged Fuel Strainer?	Clean or Replace.
	Clogged Air Cleaner?	Clean or Replace.
	Defective Idle Control Device?	Replace.
	Disconnected Wiring?	Check and Repair Wiring.
Engine starts and "Idle Control Switch" is in OFF position. Engine speed rises and battery discharges too soon.	Defective Engine Regulator?	Replace Regulator.
	Defective Wiring?	Repair or Replace Wiring.
Engine starts and "Idle Control Switch" is in OFF position. Engine speed rises and engine seems overloaded.	Defective Alternator?	Repair or Replace Alternator.
	Damaged Alternator Bearing?	Replace Alternator Bearings.
Engine starts and "Idle Control Switch" is in OFF position. Engine speed rises and engine has abnormal noise.	Loose Engine Parts?	Check All Engine Parts For Tightness.
	Defective Alternator?	Check Alternator for Damaged Bearing or Loose Clamping Bolts.
Engine starts and "Idle Control Switch" is in OFF position. Engine speed rises and remains at high speed when Idle Control switch is placed in the ON position.	Defective Idle Control Device?	Repair or Replace Idle Control Device.
	Defective Idle Control Switch?	Replace Idle Control Switch.
	Defective Solenoid?	Replace Solenoid.
	Defective Relay?	Replace Relay.

TROUBLESHOOTING (ENGINE)

Table 11. Engine Troubleshooting

SYMPTOM	POSSIBLE PROBLEM	SOLUTION
Engine does not start.	No fuel?	Replenish fuel.
	Air in the fuel system?	Bleed system.
	Water in the fuel system?	Remove water from fuel tank.
	Fuel pipe clogged?	Clean fuel pipe.
	Fuel filter clogged?	Clean or change fuel filter.
	Excessively high viscosity of fuel or engine oil at low temperature?	Use the specified fuel or engine oil.
	Fuel with low cetane number?	Use the specified fuel.
	Fuel leak due to loose injection pipe retaining nut?	Tighten nut.
	Incorrect injection timing?	Adjust.
	Fuel cam shaft worn?	Replace.
	Injection nozzle clogged?	Clean injection nozzle.
	Injection pump malfunctioning?	Repair or replace.
	Seizure of crankshaft, camshaft, piston, cylinder liner or bearing?	Repair or replace.
	Compression leak from cylinder?	Replace head gasket, tighten cylinder head bolt, glow plug and nozzle holder.
	Improper valve timing?	Correct or replace timing gear.
	Piston ring and liner worn?	Replace.
Excessive valve clearance?	Adjust.	
Starter does not run.	Battery discharged?	Charge battery.
	Starter malfunctioning?	Repair or replace.
	Key switch malfunctioning?	Repair or replace.
	Wiring disconnected?	Connect wiring.

TROUBLESHOOTING (ENGINE)

Table 11. Engine Troubleshooting (Continued)

SYMPTOM	POSSIBLE PROBLEM	SOLUTION
Engine revolution is not smooth.	Fuel filter clogged or dirty?	Clean or change.
	Air cleaner clogged?	Clean or change.
	Fuel leak due to loose injection pipe retaining nut?	Tighten nut.
	Injection pump malfunctioning?	Repair or replace.
	Incorrect nozzle opening pressure?	Adjust.
	Injection nozzle stuck or clogged?	Repair or replace.
	Fuel over flow pipe clogged?	Clean.
	Governor malfunctioning?	Repair.
Either white or blue exhaust gas is observed.	Excessive engine oil?	Reduce to the specified level.
	Piston ring and liner worn or stuck?	Repair or replace.
	Incorrect injection timing?	Adjust.
	Deficient compression?	Adjust top clearance.
Either black or dark gray exhaust gas is observed.	Overload?	Lessen the load.
	Low grade fuel used?	Use the specified fuel.
	Fuel filter clogged?	Clean or change.
	Air cleaner clogged?	Clean or change.
	Deficient nozzle injection?	Repair or replace the nozzle.
Deficient output.	Incorrect injection timing?	Adjust.
	Engine's moving parts seem to be seizing?	Repair or replace.
	Uneven fuel injection?	Repair or replace the injection pump.
	Deficient nozzle injection?	Repair or replace the nozzle.
	Compression leak?	Replace head gasket, tighten cylinder head bolt, glow plug and nozzle holder.

OPERATION MANUAL

HERE'S HOW TO GET HELP

PLEASE HAVE THE MODEL AND SERIAL
NUMBER ON-HAND WHEN CALLING

UNITED STATES

Multiquip Inc.

(310) 537- 3700
6141 Katella Avenue Suite 200
Cypress, CA 90630
E-MAIL: mq@multiquip.com
WEBSITE: www.multiquip.com

CANADA

Multiquip

(450) 625-2244
4110 Industriel Boul.
Laval, Quebec, Canada H7L 6V3
E-MAIL: infocanada@multiquip.com

UNITED KINGDOM

Multiquip (UK) Limited Head Office

0161 339 2223
Unit 2, Northpoint Industrial Estate,
Globe Lane,
Dukinfield, Cheshire SK16 4UJ
E-MAIL: sales@multiquip.co.uk

© COPYRIGHT 2019, MULTIQUIP INC.

Multiquip Inc, the MQ logo and the MQ Power logo are registered trademarks of Multiquip Inc. and may not be used, reproduced, or altered without written permission. All other trademarks are the property of their respective owners and used with permission.

This manual MUST accompany the equipment at all times. This manual is considered a permanent part of the equipment and should remain with the unit if resold.

The information and specifications included in this publication were in effect at the time of approval for printing. Illustrations, descriptions, references and technical data contained in this manual are for guidance only and may not be considered as binding. Multiquip Inc. reserves the right to discontinue or change specifications, design or the information published in this publication at any time without notice and without incurring any obligations.

Manufactured for
MQ Power Inc.
by
DENYO MANUFACTURING CO.

