

OPERATION MANUAL



WHISPERWATT™ SERIES MODEL DCA125SSIU4F 60Hz GENERATOR (ISUZU BR-4HK1X DIESEL ENGINE)

INSTRUCTION MANUAL NO. M3844300534A

Revision #8 (02/11/25)

To find the latest revision of this publication or
associated parts manual, visit our website at:

www.mqpower.com



THIS MANUAL MUST ACCOMPANY THE EQUIPMENT AT ALL TIMES.

PROPOSITION 65 WARNING



TABLE OF CONTENTS

DCA125SSIU4F 60 Hz Generator

- Proposition 65 Warning 2
- Table of Contents..... 3
- Safety Decals 4
- Safety Information 5–10
- Specifications 11
- Dimensions..... 12
- Installation 14–15
- General Information..... 16
- General Paralleling Information (Option)..... 17–19
- Major Components 20
- Engine Control Unit (ECU) 21
- Engine/Generator Control Panel 22–23
- Basler Digital Genset Controller (Option) 24–25
- Paralleling Panel (Option)..... 26–27
- Output Terminal Panel Familiarization..... 28–30
- Load Application 31
- PowerBalance® 32
- Generator Outputs..... 33
- Gauge Reading 34
- Output Terminal Panel Connections 35–36
- Inspection/Setup..... 37–42
- Generator Start-Up Procedure (Manual) 43–45
- Generator Start-Up Procedure (Auto Mode)..... 46
- Generator Shutdown Procedure..... 47
- Maintenance 48–63
- Troubleshooting..... 64
- Troubleshooting (Diagnostics)..... 65
- Troubleshooting (Generator) 66
- Troubleshooting (Engine) 67–68
- Generator Wiring Diagram (M3814000623) 69
- Engine Wiring Diagram (M3814100843) 70
- Controller Wiring Diagram (A) (M3814100903) 71
- Controller Wiring Diagram (B) (M3814101013) 72
- DC Basler Parallel Wiring Diagram (Option) 73
- AC Basler Parallel Wiring Diagram (Option)..... 74
- Battery Charger Wiring Diagram (Option) 75

NOTICE
Specifications are subject to change without notice.

SAFETY DECALS

SAFETY DECALS

Safety decals are attached to the generator as shown in Figure 1. Keep these safety decals clean at all times. When the safety decals become worn or damaged, contact your nearest dealer or the Multiquip Parts Department.

NOTICE
For safety decal part numbers, refer to the associated parts manual.

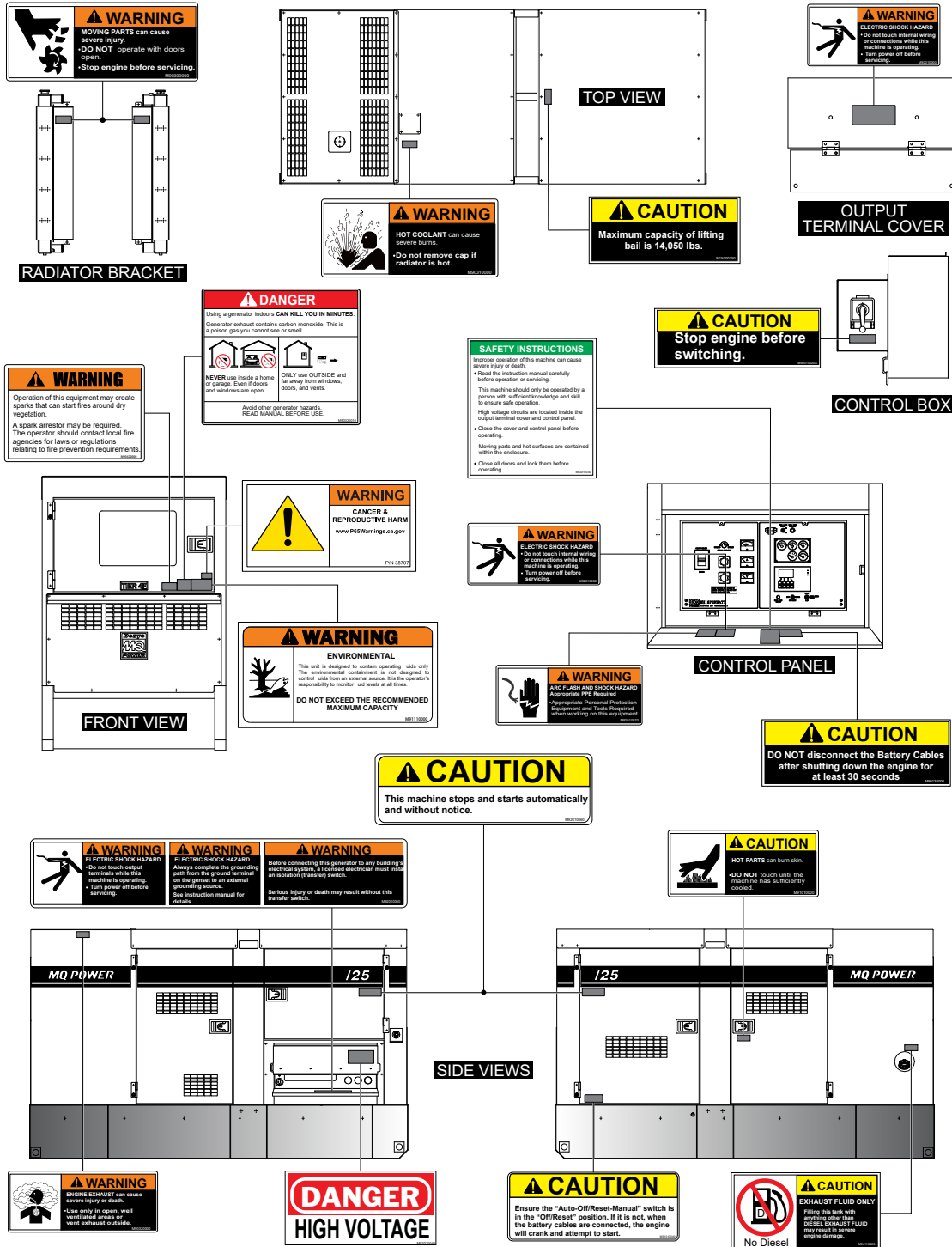

Figure 1. Safety Decals

SAFETY INFORMATION

Do not operate or service the generator before reading the entire manual. Safety precautions should be followed at all times when operating this generator. Failure to read and understand the safety messages and operating instructions could result in injury to yourself and others.







SAFETY MESSAGES

The four safety messages shown below will inform you about potential hazards that could injure you or others. The safety messages specifically address the level of exposure to the operator and are preceded by one of four words: **DANGER**, **WARNING**, **CAUTION** or **NOTICE**.

SAFETY SYMBOLS

 DANGER
Indicates a hazardous situation which, if not avoided, WILL result in DEATH or SERIOUS INJURY .
 WARNING
Indicates a hazardous situation which, if not avoided, COULD result in DEATH or SERIOUS INJURY .
 CAUTION
Indicates a hazardous situation which, if not avoided, COULD result in MINOR or MODERATE INJURY .
NOTICE
Addresses practices not related to personal injury.

Potential hazards associated with the operation of this generator will be referenced with hazard symbols which may appear throughout this manual in conjunction with safety messages.

Symbol	Safety Hazard
	Lethal exhaust gas hazards
	Explosive fuel hazards
	Burn hazards
	Overspeed hazards
	Rotating parts hazards
	Pressurized fluid hazards
	Electric shock hazards

SAFETY INFORMATION

GENERAL SAFETY

⚠ CAUTION

- **NEVER** operate this generator without proper protective clothing, shatterproof glasses, respiratory protection, hearing protection, steel-toed boots and other protective devices required by the job or city and state regulations.





- **NEVER** operate this generator when not feeling well due to fatigue or illness, or when on medication. 
- **NEVER** operate this generator under the influence of drugs or alcohol.



- **ALWAYS** check the generator for loosened threads or bolts before starting.
- **NEVER** use the generator for any purpose other than its intended purposes or applications.

NOTICE

- This generator should only be operated by trained and qualified personnel 18 years of age and older.
- Whenever necessary, replace nameplate, operation and safety decals when they become difficult to read.
- Manufacturer does not assume responsibility for any accident due to equipment modifications. Unauthorized modification of the generator will void all warranties.
- **NEVER** use accessories or attachments that are not recommended by MQ Power for this generator. Damage to the generator and/or injury to the user may result.
- **ALWAYS** know the location of the nearest **fire extinguisher**. 
- **ALWAYS** know the location of the nearest **first aid kit**. 

- **ALWAYS** know the location of the nearest phone or **keep a phone on the job site**. Also, know the phone numbers of the nearest **ambulance, doctor, and fire department**. This information will be invaluable in the case of an emergency.



GENERATOR SAFETY

⚠ DANGER

- **NEVER** operate the generator in an explosive atmosphere or near combustible materials. An explosion or fire could result causing **severe bodily harm or even death**. 

⚠ WARNING

- **NEVER** disconnect any **emergency or safety devices**. These devices are intended for operator safety. Disconnection of these devices can cause **severe injury, bodily harm or even death**. Disconnection of any of these devices will void all warranties.

⚠ CAUTION

- **NEVER** lubricate components or attempt service on a **running generator**.

NOTICE

- **ALWAYS** ensure the generator is on level ground before use.
- **ALWAYS** keep the generator in proper running condition.
- Fix damage to the generator and replace any broken parts immediately.
- **ALWAYS** store the generator properly when it is not being used. The generator should be stored in a clean, dry location out of the reach of children and unauthorized personnel.

SAFETY INFORMATION

ENGINE SAFETY

DANGER

■ The engine fuel exhaust gases contain poisonous carbon monoxide. This gas is colorless and odorless, and can cause **death** if inhaled.

■ The engine of this generator requires an adequate, free flow of cooling air. **NEVER** operate this equipment in any enclosed or narrow area where free flow of the air is restricted. If the air flow is restricted it will cause injury to people and property and serious damage to the equipment or engine.



■ When operating the generator outdoors, **DO NOT** place the generator near doors, windows or vents that could allow carbon monoxide to enter and build up in occupied spaces.

WARNING

■ **NEVER** place hands or fingers inside the engine compartment when the engine is running.

■ **NEVER** operate the engine with heat shields or guards removed.

■ Keep fingers, hands, hair and clothing away from all moving parts to prevent injury.



■ **NEVER** operate the generator with the doors open. Stop the engine before servicing.

■ **DO NOT** remove the radiator cap while the engine is hot. High pressure boiling water will gush out of the radiator and severely scald any persons in the general area of the generator.



■ **DO NOT** remove the coolant drain plug while the engine is hot. Hot coolant will gush out of the coolant tank and severely scald any persons in the general area of the generator.

■ **DO NOT** drain the engine oil while the engine is hot. Hot oil will gush out and severely scald any persons near the generator.

■ Operation of the generator may create sparks that can start fires around dry vegetation. A spark arrestor may be required. The operator should contact local fire agencies for laws or regulations relating to fire prevention requirements.

CAUTION

■ **NEVER** touch the hot exhaust manifold, muffler or cylinder. Allow these parts to cool before servicing the generator.



NOTICE

■ **NEVER** run the engine without an air filter or with a dirty air filter. Severe engine damage may occur. Service the air filter frequently to prevent engine malfunction.

■ **NEVER** tamper with the factory settings of the engine or engine governor. Damage to the engine or generator can result if operating in speed ranges above the maximum allowable.



■ Wet stacking is a common problem with diesel engines which are operated for extended periods with light or no load applied. When a diesel engine operates without sufficient load (less than 30-35% of the rated output), it will not operate at its optimum temperature. This will allow unburned fuel to accumulate in the exhaust system, which can foul the fuel injectors, engine valves and exhaust system, including turbochargers, and reduce the operating performance.

In order for a diesel engine to operate at peak efficiency, it must be able to provide fuel and air in the proper ratio and at a high enough engine temperature for the engine to completely burn all of the fuel.

Wet stacking does not usually cause any permanent damage and can be alleviated if additional load is applied to relieve the condition. It can reduce the system performance and increase maintenance. Applying an increasing load over a period of time until the excess fuel is burned off and the system capacity is reached usually can repair the condition. This can take several hours to burn off the accumulated unburned fuel.

SAFETY INFORMATION

FUEL SAFETY

DANGER

- **NEVER** start the engine near spilled fuel or combustible fluids. Diesel fuel is extremely flammable and its vapors can cause an explosion if ignited.
- **ALWAYS** refuel in a well-ventilated area, away from sparks and open flames.
- **ALWAYS** use extreme caution when working with **flammable** liquids.
- **NEVER** fill the fuel tank while the engine is **running** or **hot**.
- **NEVER** overfill the fuel tank. Spilled fuel can ignite if it comes into contact with hot engine parts or sparks from the ignition system.
- Store fuel in appropriate containers, in well-ventilated areas and away from sparks and flames.
- **NEVER** use fuel as a cleaning agent.
- **NEVER** smoke around or near the equipment. Fire or explosion could result from fuel vapors or if fuel is spilled on a hot engine.



TOWING SAFETY

CAUTION

- Check with your local county or state safety towing regulations, in addition to meeting **Department of Transportation (DOT) Safety Towing Regulations**, before towing your generator.
- Refer to the MQ Power trailer manual for additional safety information.
- In order to reduce the possibility of an accident while transporting the generator on public roads, **ALWAYS** make sure that the trailer that supports the generator and the towing vehicle are both mechanically sound and in good operating condition.
- **ALWAYS** shut down the engine before transporting.



- Make sure the hitch and coupling of the towing vehicle are rated equal to or greater than the trailer **gross vehicle weight rating**.
- **ALWAYS** inspect the hitch and coupling for wear. **NEVER** tow a trailer with defective hitches, couplings, chains, etc.
- Check the tire air pressure on both the towing vehicle and the trailer. **Inflate trailer tires as indicated on side wall of tire**. Also check the tire tread wear on both vehicles.
- **ALWAYS** make sure the trailer is equipped with **safety chains**.
- **ALWAYS** properly attach the trailer's safety chains to the towing vehicle.
- **ALWAYS** make sure the vehicle and trailer directional, backup, brake, and trailer lights are connected and working properly.
- DOT requirements include the following:
 - Connect and test electric brake operation.
 - Secure portable power cables in cable tray with tie wraps.
- The maximum speed for highway towing is **55 MPH** unless posted otherwise. Recommended off-road towing is not to exceed **15 MPH** or less depending on the type of terrain.
- Avoid sudden stops and starts. These can cause skidding or jackknifing. Smooth, gradual starts and stops will improve towing.
- Avoid sharp turns to prevent rolling.
- The trailer should be adjusted to a level position at all times when towing.
- Raise and lock the trailer wheel stand in the upright position when towing.
- Place **chock blocks** underneath the wheels to prevent **rolling** while parked.
- Place **support blocks** underneath the trailer's bumper to prevent **tipping** while parked.
- Use the trailer's swivel jack to adjust the trailer height to a level position while parked.

SAFETY INFORMATION

ELECTRICAL SAFETY

DANGER

- **NEVER** touch the output terminals during operation. Contact with the output terminals during operation can cause **electrocution, electrical shock, or burn**.



- The electrical voltage required to operate the generator can cause **severe injury or even death** through physical contact with live circuits. Turn the generator and all circuit breakers **OFF** before performing maintenance on the generator or making contact with the output terminals.

- **NEVER** insert any objects into the output receptacles during operation. This is extremely dangerous. The possibility exists of **electrical shock, electrocution or death**.



- Backfeed to a utility system can cause **electrocution** and/or property damage. **NEVER** connect the generator to a building's electrical system without a transfer switch or other approved device. All installations should be performed by a **licensed electrician** in accordance with all applicable laws and electrical codes. Failure to do so could result in electrical shock or burn, causing **serious injury or even death**.



Power Cord/Cable Safety

DANGER

- **NEVER** let power cords or cables **lay in water**.
- **NEVER** stand in water while AC power from the generator is being transferred to a load.
- **NEVER** use **damaged** or **worn** cables or cords when connecting equipment to the generator. Inspect the insulation for cuts.
- **NEVER** grab or touch a live power cord or cable with wet hands. The possibility exists of **electrical shock, electrocution or death**.

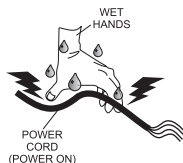

- Make sure power cables are securely connected to the generator's output receptacles. Incorrect connections may cause electrical shock and damage to the generator.

NOTICE

- **ALWAYS** make certain that the proper power or extension cord has been selected for the job. See the Cable Selection Chart in this manual.

Grounding Safety

DANGER

- **ALWAYS** make sure that electrical circuits are properly grounded to a suitable earth ground (ground rod) per the National Electrical Code (NEC) and local codes before operating the generator. **Severe injury or death by electrocution** can result from operating an ungrounded generator.
- **NEVER** use gas piping as an electrical ground.

BATTERY SAFETY

DANGER

- **DO NOT** drop the battery. There is a possibility that the battery will explode.
- **NEVER** expose the battery to open flames, sparks, cigarettes, etc. The battery contains combustible gases and liquids. If these gases and liquids come into contact with a flame or spark, an explosion could occur.



WARNING

- **ALWAYS** wear safety glasses when handling the battery to avoid eye irritation. The battery contains acids that can cause injury to the eyes and skin.
- Use well-insulated gloves when picking up the battery.
- **ALWAYS** keep the battery charged. If the battery is not charged, combustible gas will build up.
- **ALWAYS** recharge the battery in a well-ventilated environment to avoid the risk of a dangerous concentration of combustible gases.
- If the battery liquid (dilute sulfuric acid) comes into contact with **clothing or skin**, rinse skin or clothing immediately with plenty of water.



SAFETY INFORMATION

- If the battery liquid (dilute sulfuric acid) comes into contact with **eyes**, rinse eyes immediately with plenty of water and contact the nearest doctor or hospital to seek medical attention.

CAUTION

- **ALWAYS** disconnect the **NEGATIVE** battery terminal before performing service on the generator.
- **ALWAYS** keep battery cables in good working condition. Repair or replace all worn cables.

ENVIRONMENTAL SAFETY/DECOMMISSIONING

NOTICE

Decommissioning is a controlled process used to safely retire a piece of equipment that is no longer serviceable. If the equipment poses an unacceptable and unrepairable safety risk due to wear or damage or is no longer cost effective to maintain (beyond life-cycle reliability) and is to be decommissioned (demolition and dismantlement), be sure to follow the rules below:

- **NEVER** pour waste or oil directly onto the ground, down a drain, or into any water source.
- Contact your country's Department of Public Works or recycling agency in your area and arrange for proper disposal of any electrical components, waste or oil associated with this equipment.
- When the life cycle of this equipment is over, remove the battery and bring it to an appropriate facility for lead reclamation. Use safety precautions when handling batteries that contain sulfuric acid.
- When the life cycle of this equipment is over, it is recommended that the frame and all other metal parts be sent to a recycling center.



Metal recycling involves the collection of metal from discarded products and its transformation into raw materials to use in manufacturing a new product.

Recyclers and manufacturers alike promote the process of recycling metal. Using a metal recycling center promotes energy cost savings.

EMISSIONS INFORMATION

NOTICE

The diesel engine used in this equipment has been designed to reduce harmful levels of carbon monoxide (CO), hydrocarbons (HC), and nitrogen oxides (NOx) contained in diesel exhaust emissions.

This engine has been certified to meet US EPA evaporative emissions requirements in the installed configuration.

Attempting to modify or make adjustments to the engine emission system by unauthorized personnel without proper training could damage the equipment or create an unsafe condition.

Additionally, modifying the fuel system may adversely affect evaporative emissions, resulting in fines or other penalties.

Emission Control Label

The emission control label is an integral part of the emission system and is strictly controlled by regulations.

The label must remain with the engine for its entire life.

If a replacement emission label is needed, please contact your authorized engine distributor.

SPECIFICATIONS

Table 1. Generator Specifications		
Model	DCA125SSIU4F	
Type	Revolving field, self-ventilated, open protected type synchronous generator	
Armature Connection	Star with Neutral	Zigzag
Phase	3	Single
Standby Output	110 kW (137 kVA)	79 kW
Prime Output	100 kW (125 kVA)	72 kW
3Ø Voltage (L-L/L-N) Voltage Selector Switch at 3Ø 240/139	208Y/120, 220Y/127, 240Y/139	N/A
3Ø Voltage (L-L/L-N) Voltage Selector Switch at 3Ø 480/277	416Y/240, 440Y/254, 480Y/277	N/A
1Ø Voltage (L-L/L-N) Voltage Selector Switch at 1Ø 240/120	N/A	240/120
Power Factor	0.8	1.0
Frequency	60 Hz	
Speed	1,800 rpm	
Aux. AC Power	Single phase, 60 Hz	
Subtransient	0.092	
Transient	0.132	
Synchronous	1.199	
Zero Sequence Reactance	0.007	
Overload Protection	OCR/main circuit breaker	
Aux. Voltage/Output	120V/4.8 kW (2.4 kW × 2)	
Dry Weight	5,291 lb. (2,400 kg)	
Wet Weight	6,702 lb. (3,040 kg)	
Table 2. Engine Specifications		
Model	Isuzu BR-4HK1X Final Tier 4	
Type	4-cycle, water-cooled, direct injection, turbocharged with intercooler and cooled EGR	
No. of Cylinders	4	
Bore × Stroke	4.53 in. × 4.92 in. (115 mm × 125 mm)	
Displacement	719 cu. in. (5.2 liters)	
Rated Output	152 hp @ 1,800 rpm	
Starting	Electric	
Coolant Capacity	10.3 gal. (39.0 liters) ¹	
Lube Oil Capacity	6.0 gal. (22.9 liters) ²	
Lubricating Oil Type	API service class CJ-4 or JASO DH-2	
DEF Tank Capacity	7.4 gal. (28 liters)	
Fuel Type	#2 diesel fuel (ultra low sulfur diesel fuel only)	
Fuel Tank Capacity	178 gal. (680 liters)	
Fuel Consumption	7.1 gal. (26.9 L)/hr. at full load	5.6 gal. (21.2 L)/hr. at 3/4 load
	4.1 gal. (15.5 L)/hr. at 1/2 load	2.6 gal. (10.0 L)/hr. at 1/4 load
Battery	4D (CCA 0°F 1050A) × 1	

¹ Includes engine and radiator with hoses.

² Includes filters.

DIMENSIONS

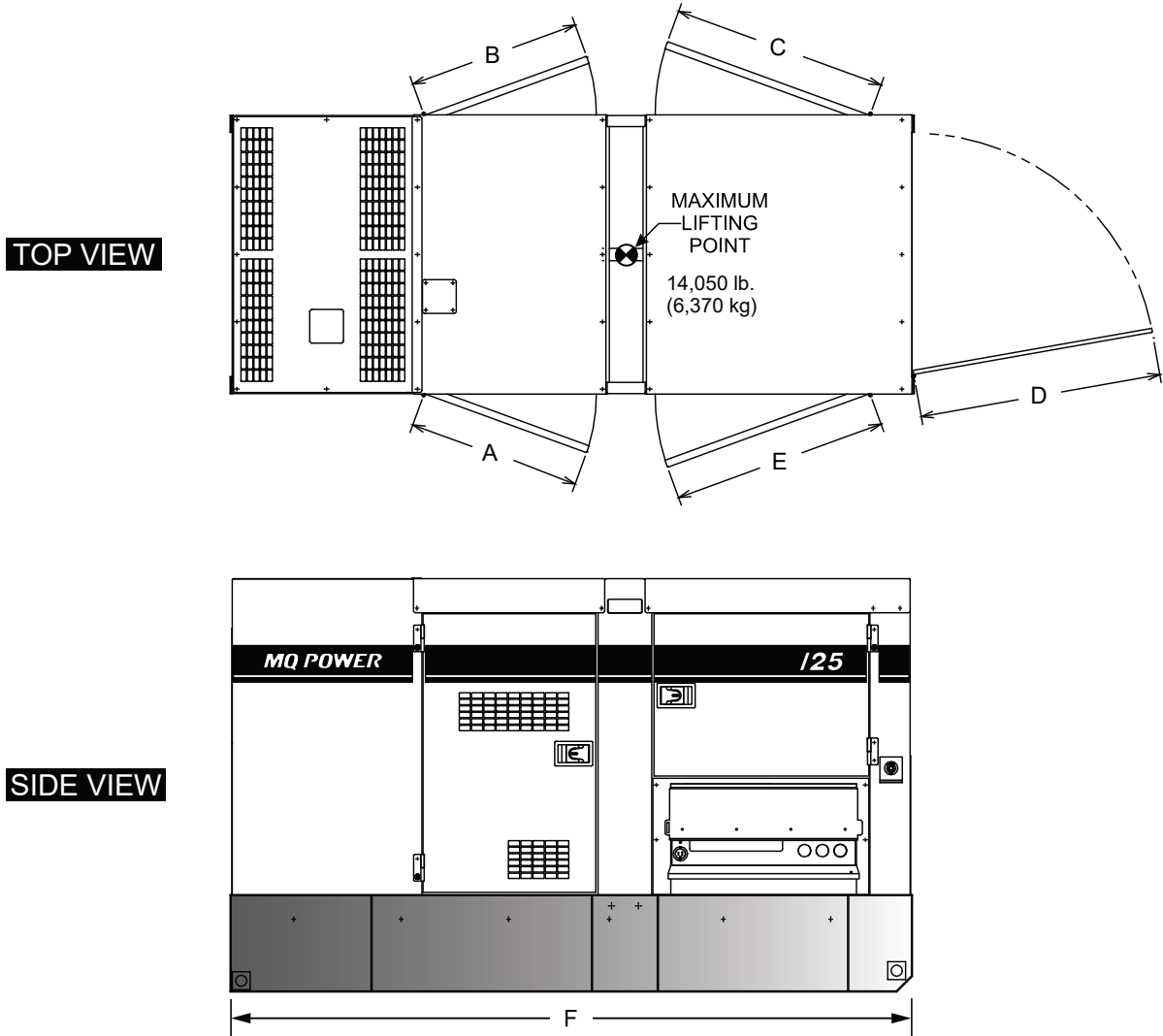

Figure 2. Dimensions

Table 3. Dimensions			
Reference Letter	Dimension in. (mm)	Reference Letter	Dimension in. (mm)
A	30.32 (770)	E	37.80 (960)
B	30.32 (770)	F	120.08 (3,050)
C	37.80 (960)	G	72.83 (1,850)
D	42.52 (1,080)	H	48.82 (1,240)

GENERATOR GROUNDING

ALWAYS refer to Article 250 (Grounding and Bonding) of the National Electrical Code (NEC).

NOTICE

ALWAYS check with state, province, district, and municipalities for electrical grounding requirements before using the generator.

EXAMPLE of how to ground the unit (Figure 3) if the condition of use requires such a device:

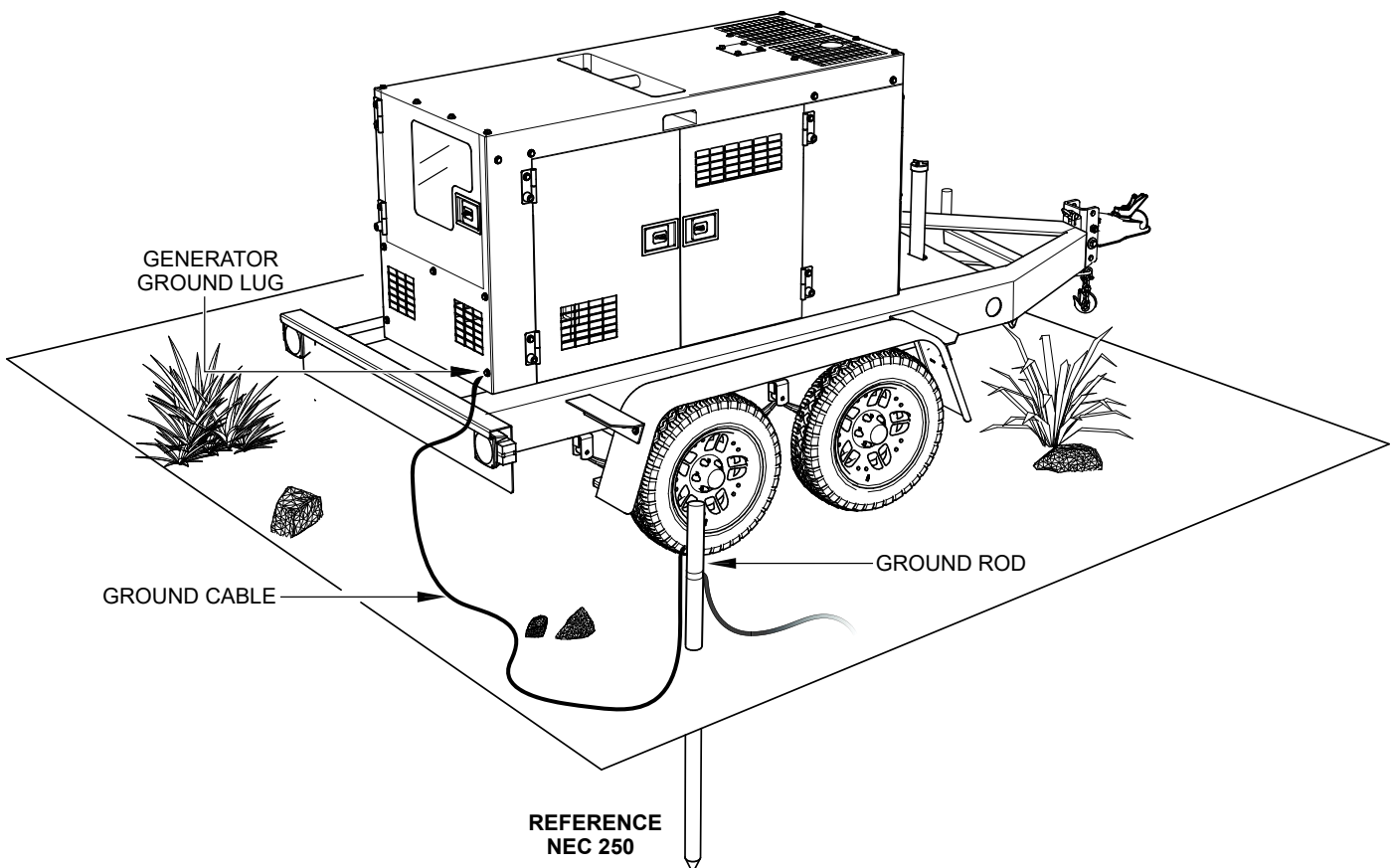

Figure 3. Typical Generator Grounding Application

NOTICE

Trailer-mounted generators are the sole responsibility of MQ Power.

OUTDOOR INSTALLATION

Install the generator in an area that is free of debris, bystanders, and overhead obstructions. Make sure the generator is on secure, level ground so that it cannot slide or shift around. Also, install the generator in a manner so that the exhaust will not be discharged in the direction of nearby homes.

The installation site must be relatively free from moisture and dust. All electrical equipment should be protected from excessive moisture. Failure to do so will result in deterioration of the insulation and will result in short circuits and grounding.

Foreign materials such as dust, sand, lint, and abrasive materials have a tendency to cause excessive wear to engine and alternator parts.

CAUTION

Pay close attention to ventilation when operating the generator inside tunnels and caves. The engine exhaust contains noxious elements. Engine exhaust must be routed to a ventilated area.

INDOOR INSTALLATION

Exhaust gases from diesel engines are extremely poisonous. Whenever an engine is installed indoors the exhaust fumes must be vented to the outside. The engine should be installed at least two feet from any outside wall. Using an exhaust pipe which is too long or too small can cause excessive back pressure which will cause the engine to heat excessively and possibly burn the valves.

MOUNTING

The generator must be mounted on a solid foundation (such as concrete) and set firmly on the foundation to isolate vibration of the generator when it is running. The generator must be mounted at least 6 inches above the floor or grade level as referenced in the National Fire Protection Association handbook (NFPA 110, Chapter 7, Section 7.4).

DO NOT remove the metal skids on the bottom of the generator. They are to resist damage to the bottom of the generator and to maintain alignment.

GENERAL INFORMATION

GENERATOR

This generator (Figure 5) is designed as a high-quality, portable (requires a trailer for transport) power source for telecom sites, lighting facilities, power tools, submersible pumps and other industrial and construction machinery.

OPERATING PANEL

The “Operating Panel” is provided with the following:

- ECU 845 Engine-Generator Controller
- Gauge Unit Assembly
 - Oil Pressure Gauge
 - Water Temperature Gauge
 - Tachometer
 - Charging Voltmeter
 - Generator Load Gauge
 - Fuel Level Gauge
 - DEF Level Gauge
 - Check DEF Lamp
 - Check Engine Lamp
 - SCR Purge Lamp
 - Refill DEF Lamp
 - Exhaust System Error Lamp
 - Low Fuel Alarm Lamp
- Panel Light/Panel Light Switch
- Hour Check Button
- Auto Start/Stop Switch
- Engine Speed Switch
- Fuel Leak Detected Alarm Lamp

CONTROL PANEL

The “Control Panel” is provided with the following:

- Frequency Meter (Hz)
- AC Ammeter (Amps)
- AC Voltmeter (Volts)
- Ammeter Change-Over Switch
- Voltmeter Change-Over Switch
- Voltage Regulator
- 3-Pole, 300-Amp Main Circuit Breaker
- “Control Box” (located behind Control Panel)
 - Automatic Voltage Regulator
 - Current Transformer
 - Overcurrent Relay
 - Starter Relay

OUTPUT TERMINAL PANEL

The “Output Terminal Panel” is provided with the following:

- Three 240/120V Output Receptacles (CS-6369), 50A
- Three Auxiliary Circuit Breakers, 50A
- Two 120V Output GFCI Duplex Receptacles (GFCI), 20A
- Two GFCI Duplex Circuit Breakers, 20A
- Five Output Terminal Lugs (3Ø Power)
- Engine Block Heater
- Battery Charger (Option)

OPEN-DELTA EXCITATION SYSTEM

Each generator is equipped with the state-of-the-art “Open-Delta” excitation system. The open-delta system consists of an electrically independent winding wound among stationary windings of the AC output section.

There are four connections of the open delta—A, B, C and D. During steady-state loads, the power from the voltage regulator is supplied from the parallel connections of A to B, A to D, and C to D. These three phases of the voltage input to the voltage regulator are then rectified and are the excitation current for the exciter section.

When a heavy load such as a motor starting or a short circuit occurs, the automatic voltage regulator (AVR) switches the configuration of the open delta to the series connection of B to C. This has the effect of adding the voltages of each phase to provide higher excitation to the exciter section and thus better voltage response during the application of heavy loads.

The connections of the AVR to the AC output windings are for sensing only. No power is required from these windings.

The open-delta design provides virtually unlimited excitation current, offering maximum motor starting capabilities. The excitation does not have a “fixed ceiling” and responds according to the demands of the required load.

ENGINE

This generator is powered by a 4-cylinder, 4-cycle, water-cooled, direct injection, turbocharged, air-cooled EGR, Isuzu BR-4HK1X diesel engine. This engine is designed to meet every performance requirement for the generator. Reference Table 2 for engine specifications.

In keeping with MQ Power’s policy of constantly improving its products, the specifications quoted herein are subject to change without prior notice.

MICROPROCESSOR CONTROL SYSTEM

The microprocessor controls the RPMs of the engine. When the engine demand increases or decreases, the microprocessor system regulates the frequency variation to $\pm 0.25\%$.

EXTENSION CABLES

When electric power is to be provided to various tools or loads at some distance from the generator, extension cords are normally used. Cables should be sized to allow for distance in length and amperage so that the voltage drop between the generator and point of use (load) is held to a minimum. Use the cable selection chart (Table 7) as a guide for selecting the proper extension cable size.

GENERAL PARALLELING INFORMATION (OPTION)

NOTICE

When the paralleling option is employed, the Basler DGC-2020HD controller **must** be installed. The factory-installed ECU-845 controller cannot be used for paralleling.

PARALLELING

Paralleling is the sharing of a load between two generator sets or more.

LOAD SHARING

Load sharing is defined as the proportional division of the **kW** and **kVAR** total load between multiple generator sets in a paralleled system.

Load sharing is essential to avoid overloading and stability problems on the system's generator sets.

ACTIVE POWER (KW) LOAD SHARING

When generator sets operate in parallel, the engine speed governor of each generator set determines the proportional sharing of the total **active** power requirements (kW) of the system.

The kW load sharing is achieved by increasing or decreasing fuel to the system's engines. As the fuel to the engine of one generator set in a group is increased it will not lead to an increase in speed and hence frequency (as it would if it were operating alone) but it will lead to an increase in the proportion of the total kW load that it will deliver.

As the fuel to the engine of one generator set in a group is decreased it will not lead to a decrease in speed and hence frequency (as it would if it were operating alone) but it will lead to a decrease in the proportion of the total kW load that it will deliver.

The control system of the generator sets (via the engine speed control system) monitors and controls the sharing of the total kW load in proportion to the relative rating of the engines on the system's generator sets.

REACTIVE POWER (KVAR) LOAD SHARING

When generator sets operate in parallel the **alternator field excitation** system of each generator set controls the proportional sharing of the total **reactive power requirements (kVAR)** of the system.

The kVAR load sharing is achieved by increasing or decreasing the field excitation to the system's alternators.

As the field excitation of one generator set in a group is **increased** (i.e. over excited) it will **not** lead to an increase in voltage (as it would if it were operating alone) but it will lead to an increase in the proportion of the total **kVAR** load it will deliver and a decrease in its power factor.

As the field excitation of one generator set in a group is **decreased** (i.e. over excited) it will **not** lead to a decrease in voltage (as it would if it were operating alone) but it will lead to a decrease in the proportion of the total **kVAR** load it will deliver and an increase in its power factor.

An undesirable circulating **reactive current** (cross current) will flow in the system if the excitation of the alternators is not matched.

ETHERNET COMMUNICATION

Ethernet communication is the preferred method for paralleling. This method supports breaker negotiation to avoid simultaneous breaker closures, kW load sharing and kVAR sharing, soft load transfers, and on and off loading.

The ethernet ports are located at the output bus splash panel area. There are two ports which are identical so either one can be used. Using a standard ethernet cable, inter-connect units to be paralleled and or sequenced.

LOAD MANAGEMENT

These generators are set up to automatically manage load, based on demand. Load management is only functional in auto mode. While in **auto** mode, if the auto start contacts are closed, load management is active by default. Load management will only run the number of units needed to support the load.

If the load demand is small, only one generator will remain running while the other generators will be in standby mode. If the load increases above 80% of its capacity, it will start the next generator. The next generator priority is based on the time remaining on the maintenance timer.

Generators with more time until scheduled maintenance will take priority over units that are almost due for maintenance. Once the second unit starts it will synchronize and parallel in then ramp up to share the load. If the load levels drop below 35% of its combined rating, the generator that is no longer needed will ramp off, shut down and wait in standby mode.

GENERAL PARALLELING INFORMATION (OPTION)

SEQUENCING

NOTICE

Ethernet communication is required when the generators are configured for the sequencing mode of operation.

These generators are capable of sequencing for control of balanced maintenance schedules. As described above, these generators can start and stop as demand raises or lowers. In addition, if a unit gets to the point of maintenance, it will ramp off and start the next generator to relieve it based on the time remaining on the maintenance timer.

After maintenance is performed, the maintenance timers should be reset to the recommended service interval. This is usually 250 hours depending on the engine oil type.

MAINTENANCE INTERVAL

Maintenance intervals are factory set for 250 hours. The maintenance interval timer will count down to zero indicating that it is time for the unit to be serviced.

Once the timer counts down to zero, a pre-alarm will appear indicating that the unit is due for maintenance. To reset the maintenance interval back to the default time of 250 hours, press and hold the "Reset" button for ten seconds.

To reset the maintenance interval using the reset button, the Maintenance Due pre-alarm must be active, and the Basler controller must display the "Overview Screen" (Main Screen).

If the maintenance timer has not yet expired and it is desired to reset the unit back to 250 hours, navigate back to the settings menu. Settings Menu->System Parameters->Engine Statistics->Hours To Maintenance.

ALARM SILENCE

Pre-Alarm Silence allows the user to suppress the toggling of the alarm screen when a new Pre-Alarm becomes active. While a Pre-Alarm is active, pressing the Alarm Silence button will suppress the fault display.

This happens to be a very handy function when the "Maintenance Interval" Pre-Alarm occurs. Right after the Pre-Alarm occurs it will begin toggling between the **pre-alarm** and the **overview screen**.

While in this mode, pressing the reset button does not reset the maintenance interval. In order to reset the maintenance interval the overview screen **must** be selected.

Pressing the alarm silence button will stop the toggling between the pre-alarm and the overview screen.

Once the overview screen is selected, the maintenance interval can be reset by pressing and holding the reset button for 10 seconds.

THREE PHASE 480V/208V PARALLEL WIRING VIA OPTIONAL CAM-LOKS

REQUIRED EQUIPMENT (USER SUPPLIED)

- Conductor Cables
- CAT5E Shielded Cable or Better
- Power Distribution Panel

The following procedure is intended to assist the user with the parallel wiring configuration for generators using the optional cam-lok connector panel.

NOTICE

Only a **qualified service technician** or **licensed electrician** with proper training should perform this installation. Follow all shop safety rules when performing this installation.

PREPARATION

1. Make sure generator is turned off and engine is cool.
2. Disconnect any loads connected to the generator.
3. Place the main circuit breaker in the **OFF** position.
4. Place the generator in an area free of dirt and debris. Make sure it is on secure, level ground.
5. Disconnect the **negative** battery cable from the battery.

GENERAL PARALLELING INFORMATION (OPTION)

3Ø-480 VAC PARALLEL WIRING CONFIGURATION

Use appropriately sized cables when connecting two generators to the power distribution panel. Refer to the NEC handbook for correct sizing of cables. Contact a licensed electrician for correct electrical wiring configuration.

! DANGER

To prevent arcing, make sure cables are securely tightened at power distribution panel. The possibility exists of the unit catching on fire, thus causing equipment damage and severe bodily harm.

NOTICE

When connecting load cables to the power distribution panel, be sure to select correctly sized load cables to handle the full load amperage of both generators (in parallel).

3Ø-208 VAC PARALLEL WIRING CONFIGURATION

Use appropriately sized cables when connecting two generators to the power distribution panel. Refer to the NEC handbook for correct sizing of cables. Contact a licensed electrician for correct electrical wiring configuration.

ETHERNET CABLE CONNECTION

1. Connect a CAT5E ethernet cable (shielded) between port 1 on both generators as shown in Figure 4.

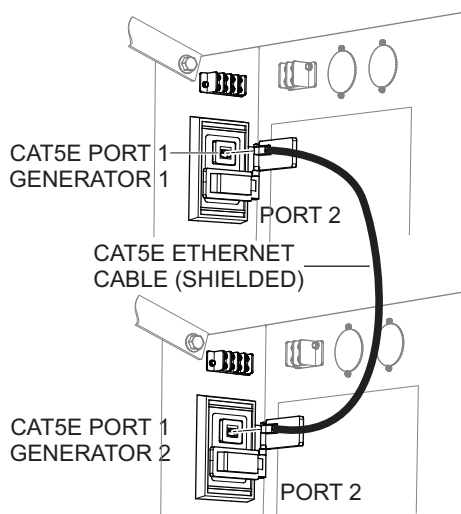

Figure 4. Ethernet Cable Connection

2. Refer to Table 4 for additional ethernet port connections.

Table 4. Ethernet Cable Connections	
Generator 1	Generator 2
Port 2	Port 1
Port 1	Port 2
Port 2	Port 2

3. Reconnect the battery.
4. Start the generator as outlined in the start-up section of this manual.

MAJOR COMPONENTS

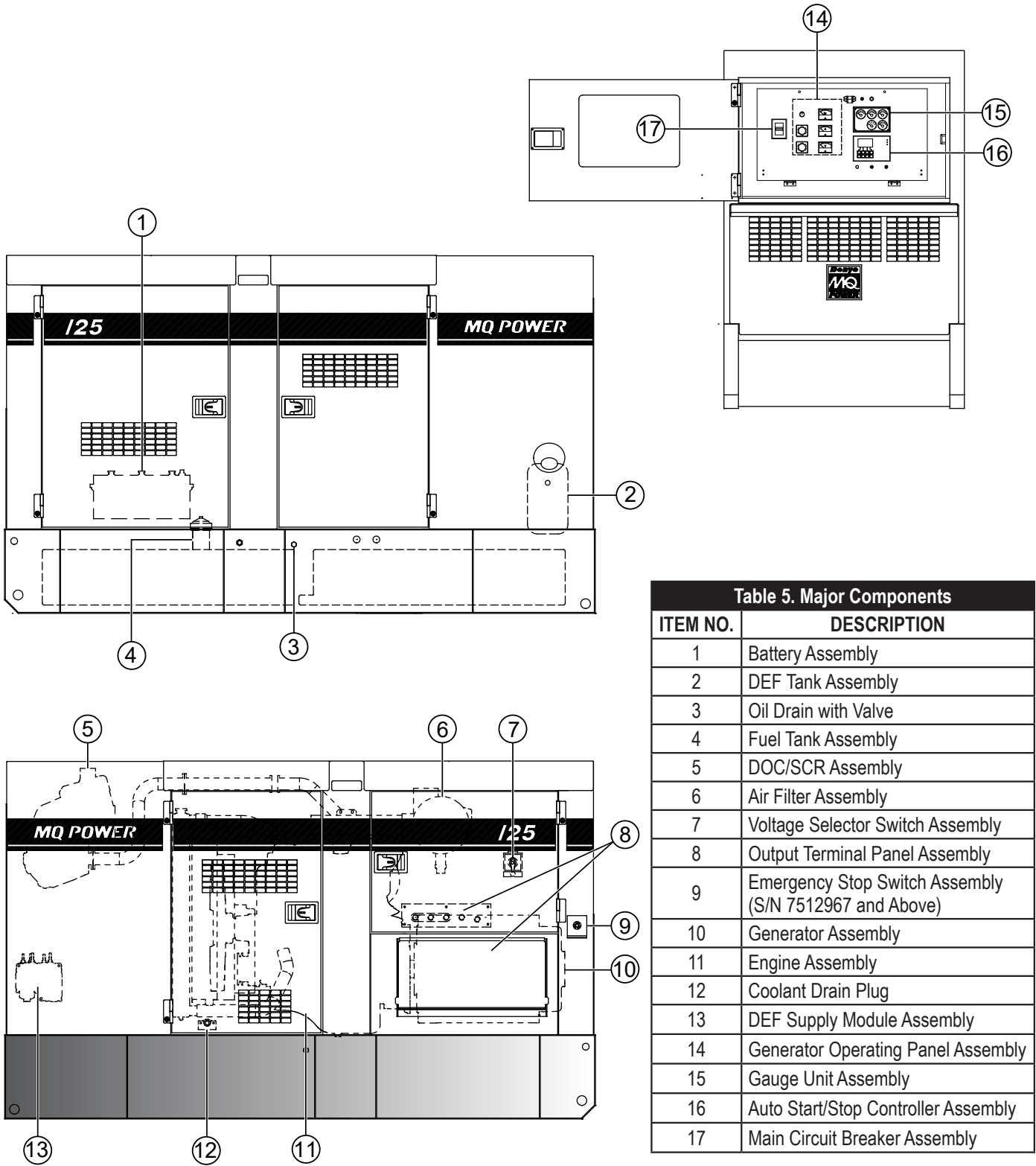

Table 5. Major Components	
ITEM NO.	DESCRIPTION
1	Battery Assembly
2	DEF Tank Assembly
3	Oil Drain with Valve
4	Fuel Tank Assembly
5	DOC/SCR Assembly
6	Air Filter Assembly
7	Voltage Selector Switch Assembly
8	Output Terminal Panel Assembly
9	Emergency Stop Switch Assembly (S/N 7512967 and Above)
10	Generator Assembly
11	Engine Assembly
12	Coolant Drain Plug
13	DEF Supply Module Assembly
14	Generator Operating Panel Assembly
15	Gauge Unit Assembly
16	Auto Start/Stop Controller Assembly
17	Main Circuit Breaker Assembly

Figure 5. Major Components

ENGINE CONTROL UNIT (ECU)

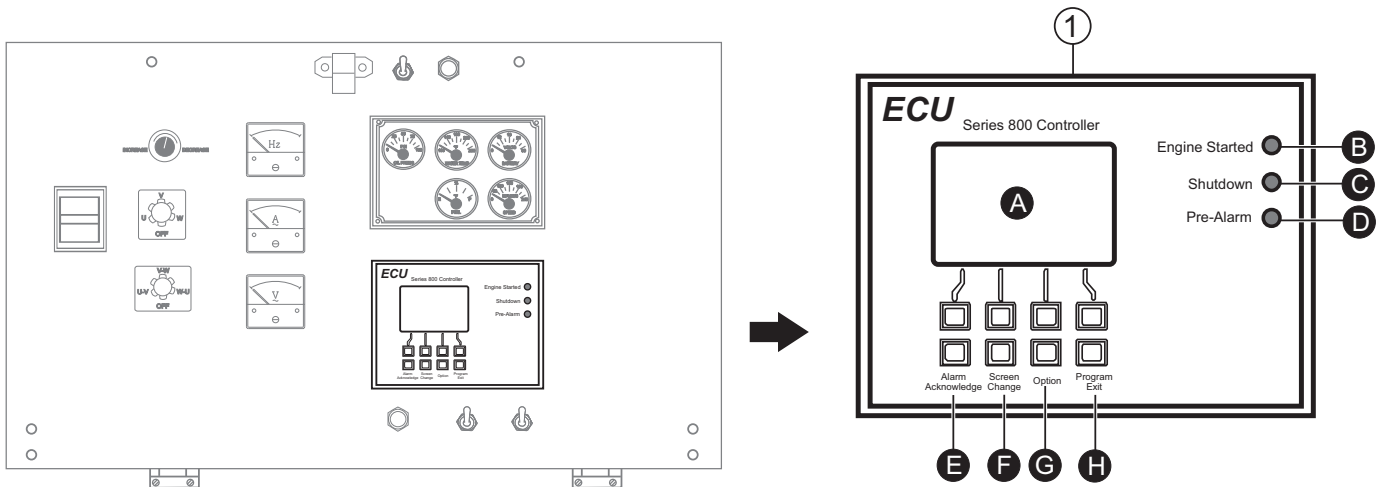

Figure 6. Engine Control Unit (ECU)

The definitions below describe the controls and functions of the Engine Control Unit (Figure 6).

1. **ECU Controller** — This engine-generator controller displays the parameters and the diagnostic troubleshooting messages of the engine.
 - A. **ECU Display Screen** — Engine fault diagnostic messages are shown on this LCD display screen.
 - B. **Engine Started Lamp** — This LED will light when the engine has started and is operating correctly.
 - C. **Engine Shutdown Lamp** — When an engine failure has occurred this lamp will blink, indicating that the engine has been shut down. The diagnostic fault message will be displayed on the LCD screen.
 - D. **Pre-Alarm Lamp** — When an engine failure has occurred this lamp will blink, indicating a pre-fault engine condition and the possibility of engine shutdown. The diagnostic fault message will be displayed on the LCD screen.
 - E. **Alarm Acknowledge Button** — When the engine experiences a fault, the “Pre Alarm Lamp” or the “Shutdown Lamp” will start blinking. Pushing this button will confirm the fault message and the blinking lamp will change to a solid lamp display. The fault message will be displayed on the screen.

When multiple engine faults occur, the lamp will continue blinking until all fault messages are confirmed. The blinking lamp will change to a solid lamp display and all current confirmed fault messages will scroll across the screen.

- F. **Screen Change Button** — When this button is pushed during operation, the screen (Figure 7) will cycle through main and secondary parameter screens.

VOLTS		AMPS			
UO	277	UV	480	U	150
VO	277	VW	480	V	150
WO	277	WV	480	W	150
	100	KW		125	KVA
	60.0	HZ		∞	00100.0h
ENGINE GENERATOR SYSTEM OK					

Figure 7. Generator Parameter Screen

NOTICE

The screen shown in Figure 7 represents the phase voltages for each phase to neutral (UO, VO and WO) and the line voltages between each phase (UV, VW and WU).

- G. **Option Button** — This button is not active. Do not use.
- H. **Program/Exit Button** — Push this button from the home screen to enter the main menu.

ENGINE/GENERATOR CONTROL PANEL

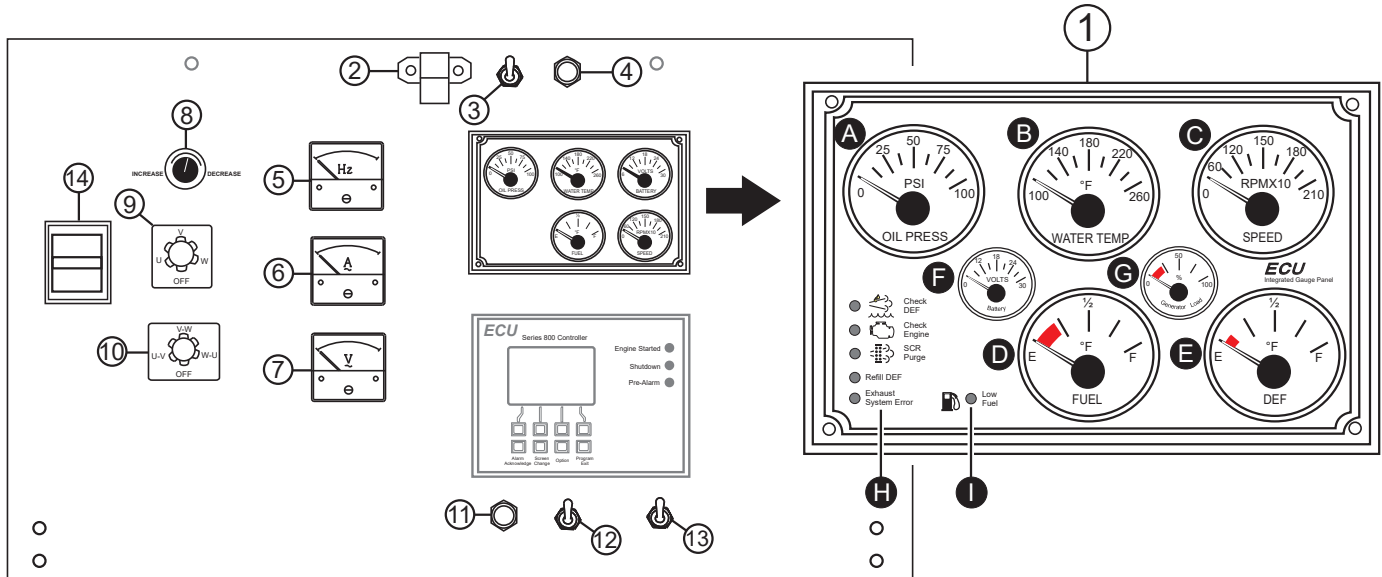

Figure 8. Gauge Unit Assembly

The definitions below describe the controls and functions of the Engine/Generator Control Panel (Figure 8).

1. **Gauge Unit Assembly** — Houses the various engine monitoring gauges: oil pressure, water temperature, engine speed RPM (tachometer), fuel, DEF, charging voltmeter, and generator load.

A. **Oil Pressure Gauge** — During normal operation this gauge should read between 42.1 and 85.6 psi (290–590 kPa). When starting the generator the oil pressure may read a little higher, but after the engine warms up the oil pressure should return to the correct pressure range.

B. **Water Temperature Gauge** — During normal operation this gauge should read between 167° and 194°F (75°–90°C).

C. **Tachometer** — Indicates engine speed in RPM for 60 Hz operation. This meter should indicate 1,800 rpm when the rated load is applied.

D. **Fuel Gauge** — Indicates the amount of diesel fuel available.

E. **DEF Level Gauge** — Indicates the DEF level in the tank. The red area on the gauge indicates low DEF level (10%).

F. **Charging Voltmeter Gauge** — During normal operation this gauge indicates 12.5–14 VDC.

G. **Generator Load Gauge** — Indicates the generator load rate. It is recommended that the load be above the red area (20%) in order to maintain sufficient exhaust temperature.

H. **Exhaust System State Indicator Lamps** — Indicate the exhaust system state or DEF state.

I. **Low Fuel Warning Lamp** — Illuminates when the fuel level in the fuel tank is low.

2. **Panel Light** — For operation at night, the panel light illuminates the control panel for ease of reading meters and gauges. Make sure the panel light switch is in the position when the light is not in use.

3. **Panel Light Switch** — When activated will turn on the control panel light.

4. **Fuel Leak Detected Alarm Lamp** — This lamp when indicates that fluids in the containment area have reached a high level.

5. **Frequency Meter** — Indicates the output frequency in hertz (Hz). Normally 60 Hz.

6. **AC Ammeter** — Indicates the amount of current the load is drawing from the generator per leg selected by the ammeter phase-selector switch.

7. **AC Voltmeter** — Indicates the output voltage present at the U, V, and W output terminal lugs.

ENGINE/GENERATOR CONTROL PANEL

8. **Voltage Regulator Control** — Allows $\pm 15\%$ manual adjustment of the generator's output voltage.
9. **Ammeter Change-Over Switch** — This switch allows the AC ammeter to indicate the current flowing to the load connected to any phase of the output terminals, or to be switched off. This switch does not affect the generator output in any fashion, it is for current reading only.
10. **Voltmeter Change-Over Switch** — This switch allows the AC voltmeter to indicate phase-to-phase voltage between any two phases of the output terminals or to be switched off.
11. **Hour Check Button** — With the engine stopped, press and hold this button. The total running hours, fuel level, and battery voltage will be displayed.
12. **Auto Start-Stop Switch** — This switch selects either manual or automatic operation. Center position is (reset).
13. **Engine Speed Switch** — This switch controls the speed of the engine, low or high.
14. **Main Circuit Breaker** — This three-pole, 300-amp main breaker is provided to protect the U,V, and W output terminal lugs from overload.

BASLER DIGITAL GENSET CONTROLLER (OPTION)

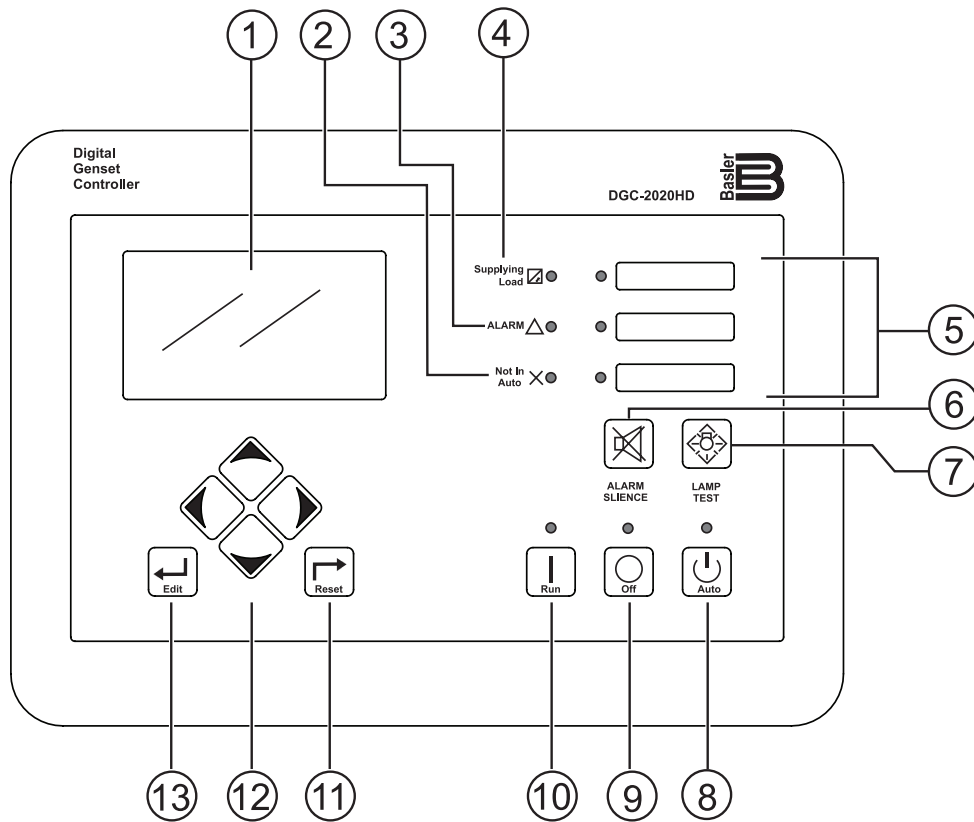

Figure 9. Basler DGC-2020HD

NOTICE

The Basler DGC-2020HD controller is an *option*. It replaces the standard ECU-845 controller when the paralleling option is employed.

BASLER DIGITAL GENSET CONTROLLER (OPTION)

The definitions below describe the controls and functions of the Digital Genset Controller (Figure 9).

1. **LCD Display** — Display consists of an LCD **color touch screen**. The backlit, 272 × 480-pixel color LCD serves as the local information source for metering, alarms, pre-alarms, and protective functions. Touch screen capability provides convenient navigation through metering and settings. Display operation is maintained down to -4°F (-20°C).
2. **Not In Auto Indicator** — This red LED lights when the DGC-2020HD is **not** operating in **Auto mode**.
3. **Alarm Indicator** — This red LED lights continuously during alarm conditions and flashes during pre-alarm conditions.
4. **Supplying Load Indicator** — This green LED lights when the generator current is greater than the emergency power supply (EPS) threshold current.
5. **Voltage Selection Indicators** — These three LEDs light to indicate the selected voltage. The **upper** lamp indicates **3-phase, 480-volt** operation. The **middle** lamp indicates **3-phase, 240-volt** operation. The **lower** lamp indicates **idle running** operation.
6. **Alarm Silence Pushbutton** — Press this button to open the relay output programmed as the horn output.
7. **Lamp Test Pushbutton** — Press this button to test the DGC-2020HD indicators by exercising all LCD pixels and lighting all LEDs.
8. **Auto Pushbutton and Mode Indicator** — Press the **Auto button** to place the DGC-2020HD in **Auto mode**. The green **Auto Mode LED** lights when Auto mode is active.

While in Auto mode, if the unit's auto-start contacts are connected to a transfer switch and the contacts between the terminals are closed, the unit will start and automatically close the circuit breaker.

If running in parallel, the Basler controller will command the unit to start and close the breaker based on load demand. If a failure occurs with another generator in the paralleled system, the controller will start and synchronize, then close the motorized breaker to electrically lock the unit in parallel.

If the bus is dead it will immediately close the circuit breaker to provide power to the load(s). If the bus is already hot from another generator it will first synchronize, then close its breaker, then slowly ramp up to share load if load is present.

9. **Off Pushbutton and Mode Indicator** — Press this button to place the DGC-2020HD in **Off mode**. The red **Off Mode LED** lights whenever the DGC-2020HD is in Off mode.
10. **Run Pushbutton and Mode Indicator** — Press this button to place the DGC-2020HD in **Run mode**. The green **Run Mode LED** lights whenever Run mode is active.
11. **Reset Pushbutton** — Press this button to cancel a settings editing session and discard any settings changes. When held, this button resets the **Breaker Management pre-alarms**. This button is also used to reset the maintenance interval when pressed for 10 seconds while viewing **Hours Until Maintenance** or the **Maintenance Due pre-alarm**.
12. **Arrow Pushbuttons** — These four buttons are used to navigate through the front panel display menus and to modify settings.
 - The **Left Arrow and Right Arrow buttons** are used to navigate through the menu levels. Press the **Right Arrow button** to move **downward** through the menu levels and press the **Left Arrow button** to move **upward** through the menu levels.
 - The **Up Arrow and Down Arrow buttons** are used to move among items within a menu level. Press the **Down Arrow button** to move to items lower on the list. Press the **Up Arrow button** to move to items higher on the list.
 - During a settings editing session, the Up Arrow and Down Arrow buttons are used to increase and decrease the value of the selected setting. The Right Arrow and Left Arrow buttons move to different digits.
13. **Edit Pushbutton** — Press the **Edit pushbutton** to start an editing session and enable changes to the DGC-2020HD settings. At the conclusion of an editing session, press this button again to save the setting changes.

PARALLELING PANEL (OPTION)

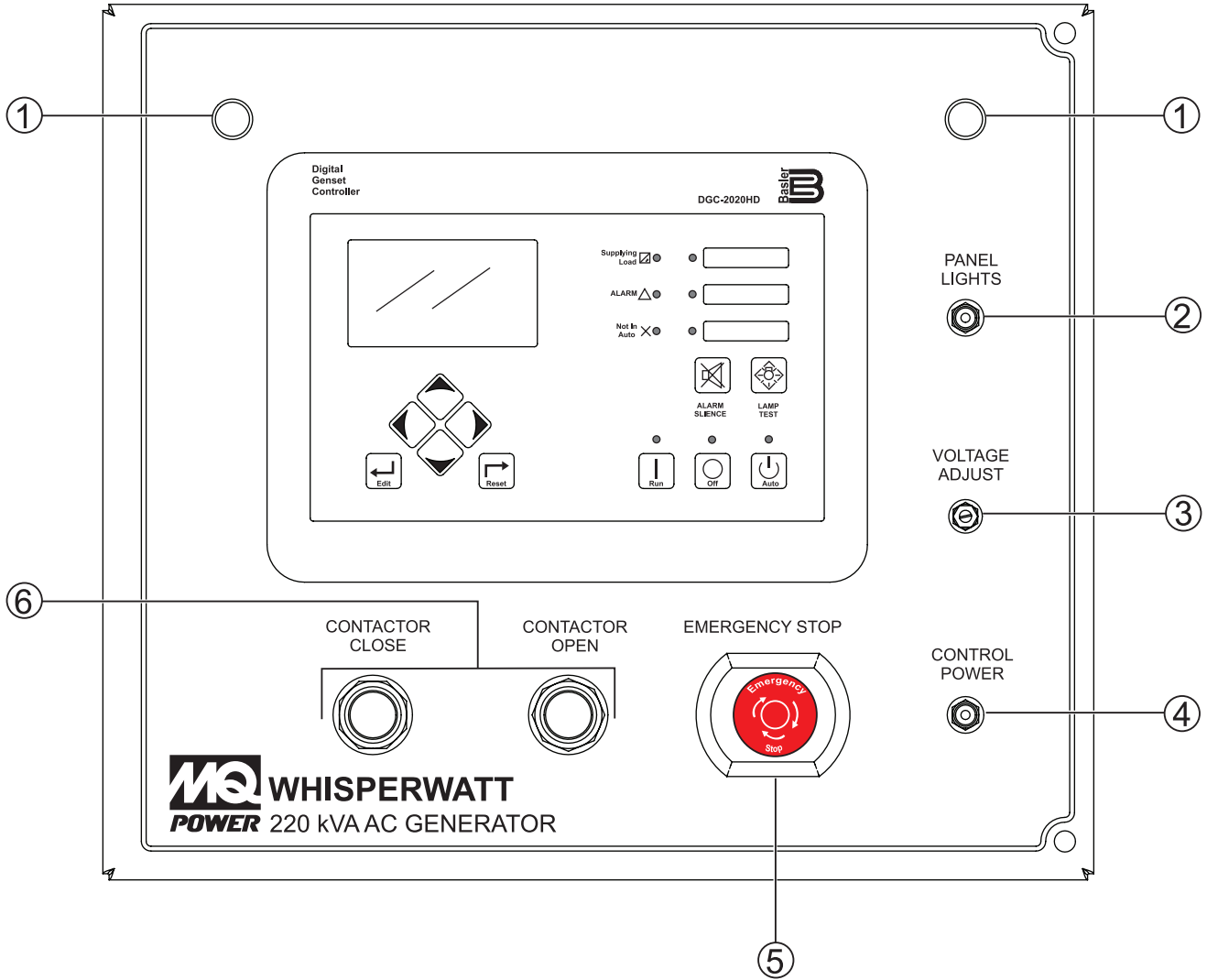

Figure 10. Paralleling Panel Components

PARALLELING PANEL (OPTION)

The definitions below describe the controls and functions of the Paralleling Panel (Figure 10).

1. **Panel Lights** — For operation at night or in dark areas, panel lights illuminate paralleling panel for ease of reading.
2. **Panel Light Switch** — When activated will turn on control panel light.
3. **Voltage Adjust Potentiometer** — The **voltage adjust potentiometer** is a way to adjust the voltage up or down for fine tuning. The adjustment sends a signal to the controller to offset the system-rated voltage (Trim Voltage). It is important that all machines are set to the same value when paralleling.

When first turning on the control power, the controller will begin its boot sequence much like a computer does. After completing the boot sequence the unit will be ready to run or be placed in auto for auto-start applications.

4. **Control Power Toggle Switch** — The control power switch is a master power switch for the digital controller. The control power switch has a latch feature that prevents powering down control power while the engine is running.
5. **Emergency Stop Button Switch** — The Emergency Stop pushbutton switch is used to stop the engine in case of emergency or to lock out operation during service. The emergency stop button **should not be used for routine stopping of the engine**.

Actuation of the Emergency stop button while the control power is on will illuminate the light on the button as well as display “Emergency Stop” on the controller display. Actuating the Emergency stop button will de-energize all controller outputs and cause the engine to stop as well as trip the circuit breaker. This condition is a latched condition that must be reset prior to restarting the engine.

The procedure for resetting the emergency stop requires several actions. Rotate the emergency stop button to release the spring latch. To clear the latch, the controller must be placed into off mode by pressing the “OFF” button. While in “OFF” mode, the “RESET” button must be pressed to clear the E-STOP fault.

For units with manually operated breakers, the breaker will need to be reset by toggling the handle down, then turning back to the “ON” position. On models with spring-charged breakers resetting the breaker is not necessary.

6. **Contactors Operation (Manual Mode)** — For manual run applications, user action is required to get the generator power to the output bus. Depending on the model, some utilize contactors in series with toggle handle circuit breakers and others have spring-charged automatic circuit breakers.

On the spring-charged types, the buttons on the breaker itself are not intended for circuit breaker operation. For instructional purposes both will be referred to as “contactor.”

There are two pushbuttons on the control panel for controlling the contactor. There is a green “CLOSE CONTACTOR” button to close the contactor and a red “OPEN CONTACTOR” button to open the contactor. These buttons illuminate to show the contactor status. If the contactor is open, the red “OPEN CONTACTOR” button will be illuminated. If the contactor is closed the green “CLOSE CONTACTOR” button will be illuminated.

These buttons can sometimes be multifunctional depending on the situation. For stand-alone operation the buttons simply close and open the contactor as expected. For paralleling the buttons can act a little different.

When the bus is already hot from another generator, pressing the green online button will initiate a synchronizing sequence before closing the contactor. There will be an image of a synchroscope on the controller display and when the voltage and phases are matched, the contactor will close.

If there was already load on the bus the unit will slowly ramp up load until it is sharing equally with the other generator(s). While sharing load with other generators, pressing the red “OPEN CONTACTOR” button once will initiate a ramp-down sequence. The unit will begin to ramp down and when at a low level of load it will automatically open its contactor. Pressing the red “OPEN CONTACTOR” button twice will immediately open the contactor.

OUTPUT TERMINAL PANEL FAMILIARIZATION

OUTPUT TERMINAL PANEL

The Output Terminal Panel (Figure 11) shown below is provided for the connection of electrical loads. Lift up on the cover to gain access to receptacles and terminal lugs.

NOTICE

Terminal O is neutral bonded to the ground from the factory.

NOTICE

Output Terminal Bolt Torque: 554.9 lbf-in (62.7 N-m)

OUTPUT TERMINAL FAMILIARIZATION

The "Output Terminal Panel" (Figure 11) is provided with the following:

- Three 240/120V Output Receptacles @ 50 amps
- Three Circuit Breakers @ 50 amps
- Two 120V GFCI receptacles @ 20 amps
- Two GFCI Circuit Breakers @ 20 amps
- Five Output Terminal Lugs (U, V, W, O, Ground)

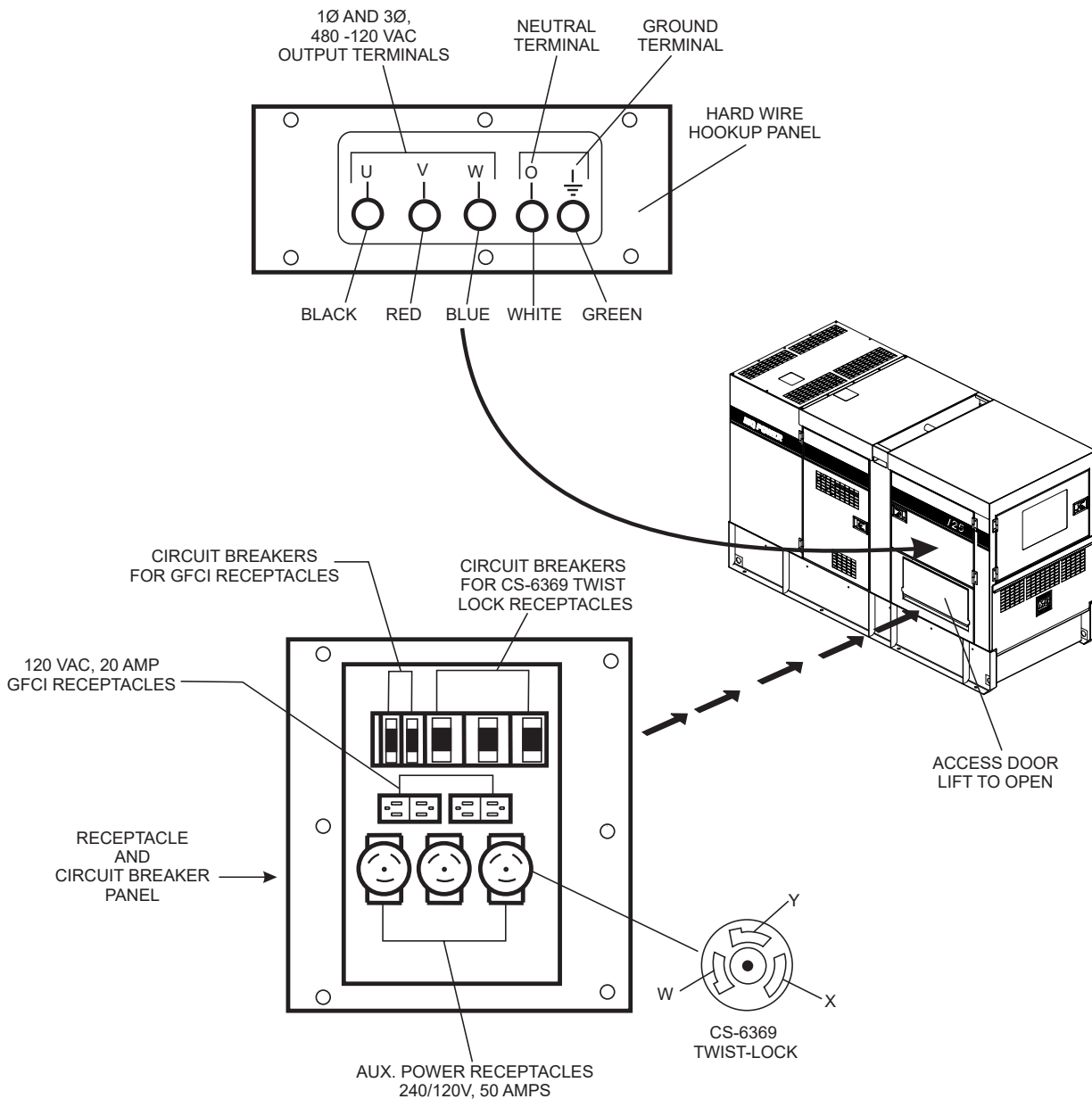

Figure 11. Output Terminal Panel

OUTPUT TERMINAL PANEL FAMILIARIZATION

120 VAC GFCI Receptacles

NOTICE

It is recommended that the GFCI receptacles be tested when the generator is initially uncrated. The receptacles should then be tested daily at startup.

There are two 120 VAC, 20-amp GFCI (duplex NEMA 5-20R) receptacles provided on the output terminal panel. These receptacles can be accessed in any **voltage selector switch** position. Each receptacle is protected by a 20-amp circuit breaker. These breakers are located directly above the GFCI receptacles. Remember the load output (current) of both GFCI receptacles is dependent on the load requirements of the U, V, and W output terminal lugs.

Pressing the **reset** button resets the GFCI receptacle after being tripped. Pressing the **test button** (See Figure 12) in the center of the receptacle will check the GFCI function. Both receptacles should be tested at least once a month.

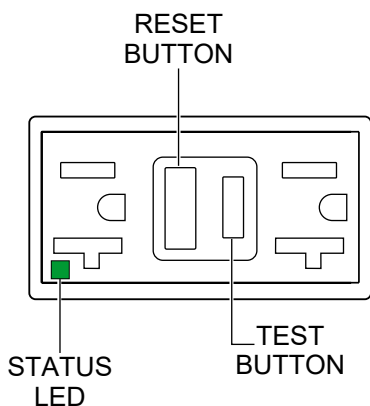

Figure 12. 120 VAC GFCI Receptacle

Twist-Lock Dual-Voltage 240/120 VAC Receptacles

There are three 240/120V, 50-amp, auxiliary twist-lock (CS-6369) receptacles (Figure 13) provided on the output terminal panel. These receptacles can **only** be accessed when the voltage selector switch is placed in the **single-phase 240/120V** position.

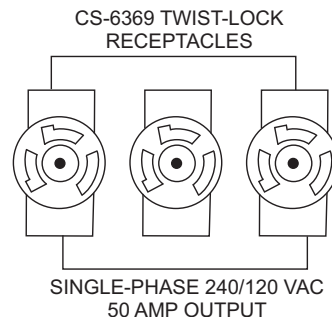

Figure 13. 240/120V Twist-Lock Auxiliary Receptacles

Each auxiliary receptacle is protected by a 50-amp circuit breaker. These breakers are located directly above the GFCI receptacles. Remember the load output (current) on all three receptacles is dependent on the load requirements of the **output terminal lugs**.

Removing the Plastic Face Plate (Hard Wire Hookup Panel)

The **Output Terminal Lugs** are protected by a plastic face plate cover (Figure 14). Unscrew the securing bolts and lift the plastic terminal cover to gain access to the terminal enclosure.

After the load wires have been securely attached to the terminal lugs, reinstall the plastic face plate.

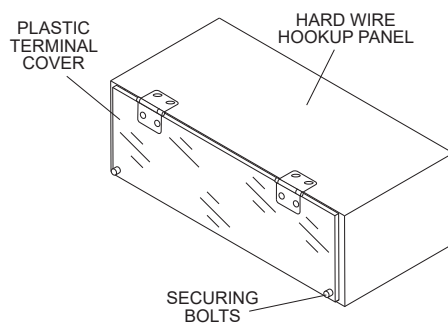

Figure 14. Plastic Face Plate (Output Terminal Lugs)

OUTPUT TERMINAL PANEL FAMILIARIZATION

Connecting Loads

Loads can be connected to the generator by the output terminal lugs, convenience receptacles, or optional cam-locks (Figure 15). Make sure to read the operation manual before attempting to connect a load to the generator.

To protect the output terminals from overload, a 3-pole, 300-amp, **main** circuit breaker is provided. Make sure to switch **ALL** circuit breakers to the **OFF** position prior to starting the engine.

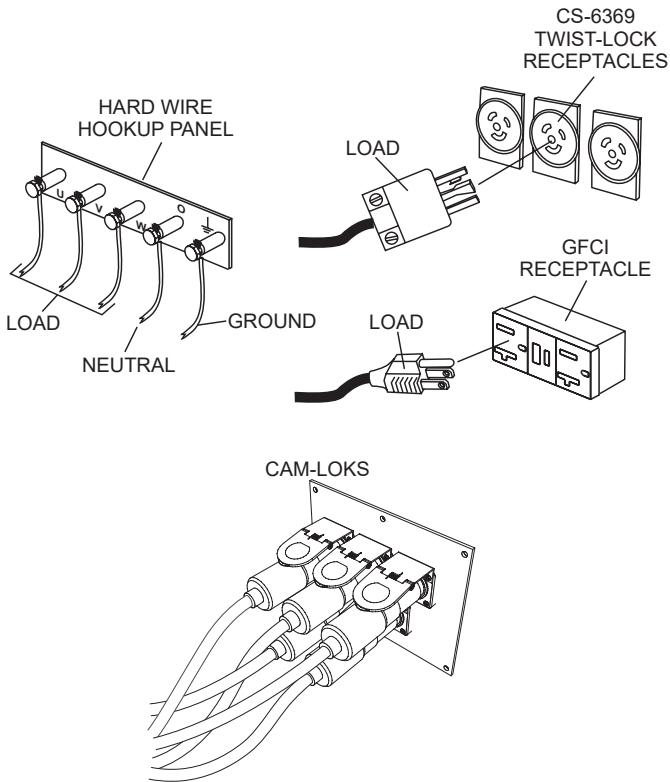

Figure 15. Connecting Loads

Overcurrent Relay

An **overcurrent relay** (Figure 16) is connected to the main circuit breaker. In the event of an overload, both the circuit breaker and the overcurrent relay may trip. If the circuit breaker cannot be reset, the **reset button** on the overcurrent relay must be pressed. The overcurrent relay is located inside the control box.

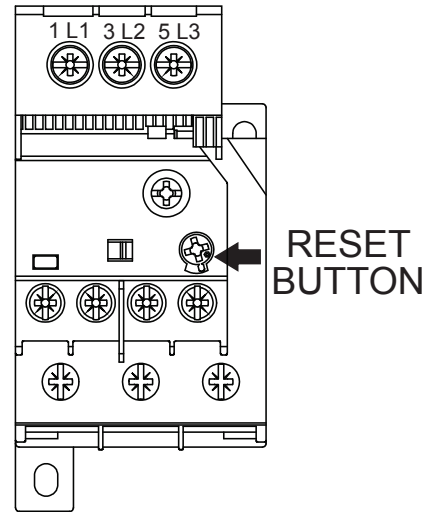

Figure 16. Overcurrent Relay

NOTICE

Remember the **overcurrent relay** monitors the current flowing from the **U, V, and W Output Terminal Lugs** to the load.

In the event of a short circuit or overcurrent condition, it will automatically trip the 300-amp main breaker.

To restore power to the **Output Terminal Panel**, press the reset button on the overcurrent relay and place the **main** circuit breaker in the **closed** position (**ON**).

LOAD APPLICATION

SINGLE-PHASE LOAD

Always be sure to check the nameplate on the generator and equipment to ensure the wattage, amperage, frequency, and voltage requirements are satisfactorily supplied by the generator for operating the equipment.

Generally, the wattage listed on the nameplate of the equipment is its rated output. Equipment may require 130–150% more wattage than the rating on the nameplate, as the wattage is influenced by the efficiency, power factor and starting system of the equipment.

NOTICE

If wattage is not given on the equipment's nameplate, approximate wattage may be determined by multiplying nameplate voltage by the nameplate amperage.

$$\text{WATTS} = \text{VOLTAGE} \times \text{AMPERAGE}$$

The power factor of this generator (single phase) is 1.0. See Table 6 below when connecting loads.

Table 6. Power Factor By Load

Type of Load	Power Factor
Single-phase induction motors	0.4–0.75
Three-phase induction	0.65–0.85
Electric heaters, incandescent lamps	1.0
Fluorescent lamps, mercury lamps	0.4–0.9
Electronic devices, communication equipment	1.0
Common power tools	0.8

Table 7. Cable Selection (60 Hz, Single-Phase Operation)

Current in Amperes	Load in Watts		Maximum Allowable Cable Length			
	At 100 Volts	At 200 Volts	#10 Wire	#12 Wire	#14 Wire	#16 Wire
2.5	300	600	1,000 ft.	600 ft.	375 ft.	250 ft.
5	600	1,200	500 ft.	300 ft.	200 ft.	125 ft.
7.5	900	1,800	350 ft.	200 ft.	125 ft.	100 ft.
10	1,200	2,400	250 ft.	150 ft.	100 ft.	
15	1,800	3,600	150 ft.	100 ft.	65 ft.	
20	2,400	4,800	125 ft.	75 ft.	50 ft.	

CAUTION: Equipment damage can result from low voltage.

NOTICE

Cable selection table is a general guideline. **ALWAYS** consult local and national electrical codes when sizing cables.

THREE-PHASE LOAD

When calculating the power requirements for 3-phase power use the following equation:

$$\text{KVA} = \frac{\text{VOLTAGE} \times \text{AMPERAGE} \times 1.732}{1000}$$

NOTICE

If 3Ø load (kVA) is not given on the equipment nameplate, approximate 3Ø load may be determined by multiplying voltage by amperage by 1.732.

NOTICE

Motors and motor-driven equipment draw much greater current for starting than during operation.

An inadequately sized connecting cable which cannot carry the required load can cause a voltage drop which can burn out the appliance or tool and overheat the cable. See Table 6.

The power factor of this generator (3 phase) is 0.8.

- When connecting a resistance load such as an incandescent lamp or electric heater, a capacity of up to the generating set's rated output (kW) can be used.
- When connecting a fluorescent or mercury lamp, a capacity of up to the generating set's rated output (kW) multiplied by 0.6 can be used.
- When connecting an electric drill or other power tools, pay close attention to the required starting current capacity.

When connecting ordinary power tools, a capacity of up to the generating set's rated output (kW) multiplied by 0.8 can be used.

DANGER

Before connecting this generator to any building's electrical system, a **licensed electrician** must install an **isolation (transfer) switch**. Serious damage to the building's electrical system may occur without this transfer switch.

PowerBalance® (Figure 14) is an optional load management solution that helps protect the engine generator from problems resulting from sustained low-load operations (defined as less than 30% of the generator full-load rating).

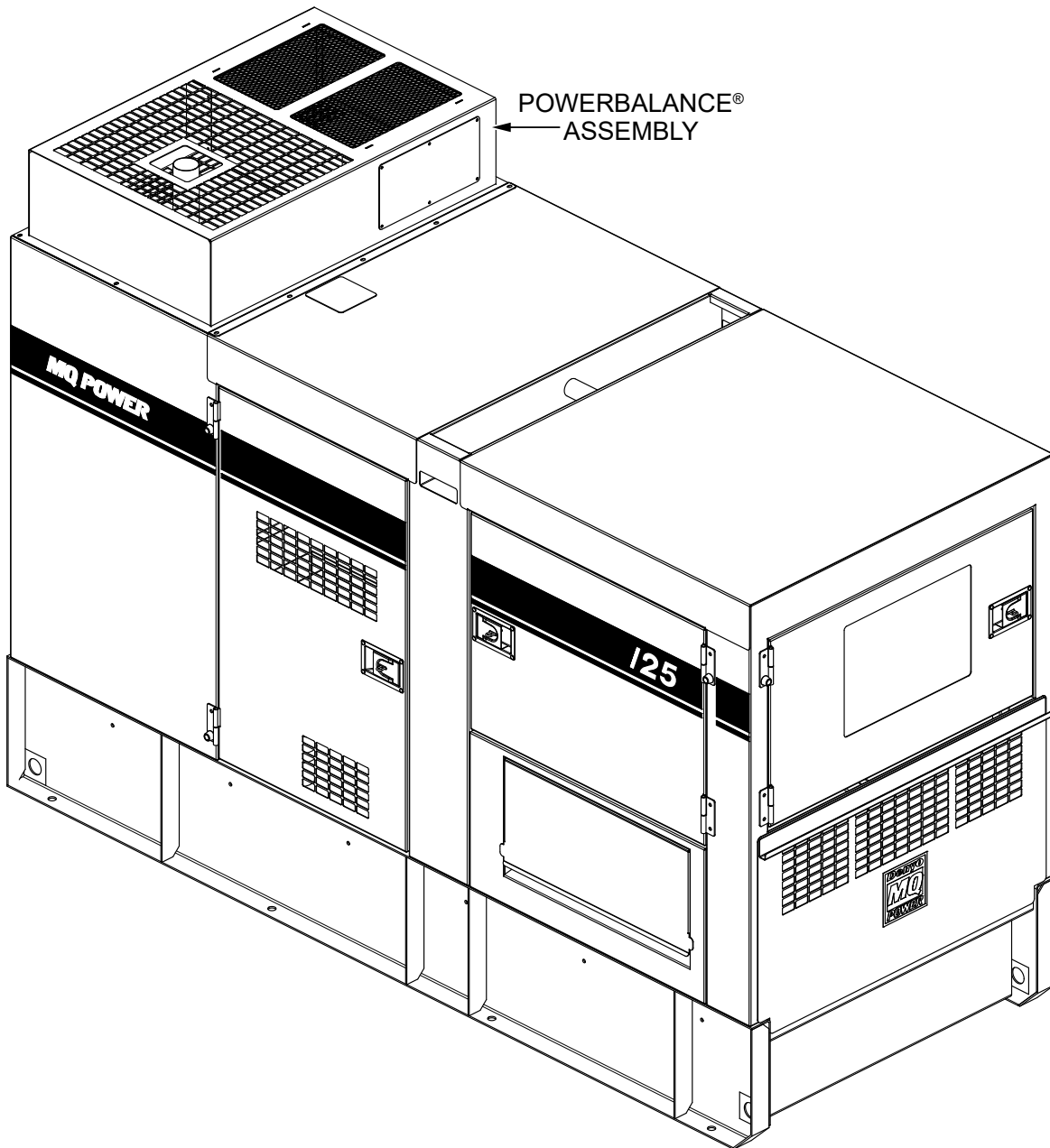

Figure 17. PowerBalance®

- PowerBalance® continuously monitors engine load. The load management controller senses and increases engine load automatically using resistive coils when the controller determines that the temperature and/or load is too low.
- When additional load demands are placed on the generator that bring it to an optimum level, PowerBalance® will automatically deactivate this additional load and remain ready for reactivation should exhaust temperatures drop.

GENERATOR OUTPUTS

GENERATOR OUTPUT VOLTAGES

A wide range of voltages (Table 8) is available for many different applications.

Table 8. Voltages Available						
UVWO Output Terminal Lugs	Voltage Selector Switch 3-Phase 240/139V Position			Voltage Selector Switch 3-Phase 480/277V Position		
	3Ø Line-Line	208V	220V	240V	416V	440V
1Ø Line-Neutral	120V	127V	139V	240V	254V	277V
Voltage Selector Switch Single-Phase 240/120V Position						
1Ø Line-Neutral/Line-Line	120V Line-Neutral	N/A	N/A	240V Line-Line	N/A	N/A

Voltage Selector Switch

Voltages are selected using the Voltage Selector switch (Figure 18) which is located above the output terminal panel's hard wire hook-up panel. This switch has been provided for ease of voltage selection.

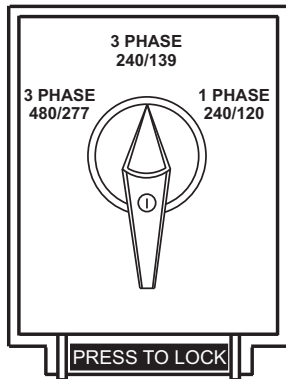

Figure 18. Voltage Selector Switch

CAUTION

NEVER change the position of the voltage selector switch while the engine is running. **ALWAYS** place the circuit breaker in the **OFF** position before selecting voltage.

Voltage Regulator

To obtain some of the voltages listed in Table 8 will require a fine voltage adjustment using the voltage regulator (Figure 19) located on the control panel.

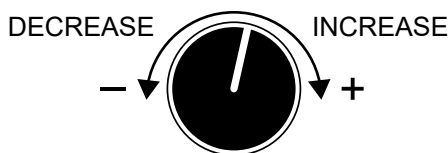

Figure 19. Voltage Regulator

Maximum Amps

Table 9 shows the **maximum** amps the generator can provide. **DO NOT** exceed the maximum amps as listed.

Table 9. Generator Maximum Amps	
Rated Voltage	Maximum Amps
1Ø 120 Volts	300 amps × 2 (zigzag)
1Ø 240 Volts	300 amps (zigzag)
3Ø 208 Volts	300 amps
3Ø 240 Volts	300 amps
3Ø 480 Volts	150 amps

GFCI Receptacle Load Capability

The load capability of the GFCI receptacles is directly related to the voltage being supplied at either the output terminals or the two twist-lock auxiliary receptacles.

Figure 24, Table 10, and Table 11 show what amount of current is available at the GFCI receptacles when the output terminals and twist-lock receptacles are in use. Be careful that your load does not exceed the available current capability at the receptacles.

Table 10. 1Ø GFCI Receptacle Load Capacity	
KW in Use Twist Lock (C6369)	Available Load Current (Amps)
1Ø 240/120V	GFCI Duplex 5-20R 120V
72.0	0
70.8	5 amps/receptacle
69.6	10 amps/receptacle
68.4	15 amps/receptacle
67.2	20 amps/receptacle

Table 11. 3Ø Generator Maximum Amps	
KVA in Use (UVWO Terminals)	Available Load Current (Amps)
3Ø 240/480V	GFCI Duplex 5-20R 120V
125	0 amps/receptacle
121	5 amps/receptacle
117	10 amps/receptacle
113	15 amps/receptacle
108	20 amps/receptacle

GAUGE READING

HOW TO READ THE AC AMMETER AND AC VOLTMETER GAUGES

The AC ammeter and AC voltmeter gauges are controlled by the AC ammeter and AC voltmeter change-over switches.

Both of these switches are located on the control panel and **DO NOT** affect the generator output. They are provided to help observe how much power is being produced at the UVWO terminal lugs.

Before taking a reading from either gauge, set the **Voltage Selector Switch** (Figure 20) to the position which produces the required voltage. Example, for 3Ø 240V, choose the center 3Ø 240/139V position on the voltage selector switch.

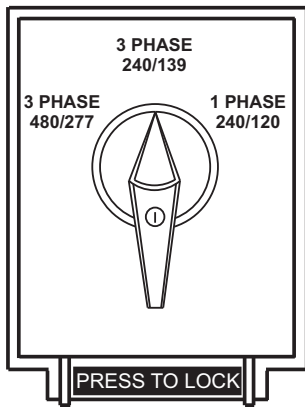

Figure 20. Voltage Selector Switch
240V/3Ø Position

AC Voltmeter Gauge Reading

Place the **AC Voltmeter Change-Over Switch** (Figure 21) in the W-U position and observe the phase-to-phase voltage reading between the W and U terminals as indicated on the **AC Voltmeter Gauge** (Figure 22).

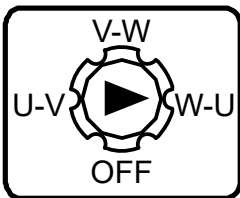

Figure 21. AC Voltmeter
Change-Over Switch

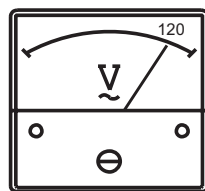

Figure 22. AC Voltmeter Gauge
(Volt Reading On W-U Lug)

AC Ammeter Gauge Reading

Place the **AC Ammeter Change-Over Switch** (Figure 23) in the U position and observe the current reading (load drain) on the U terminal as indicated on the **AC Ammeter Gauge** (Figure 24). This process can be repeated for terminals V and W.

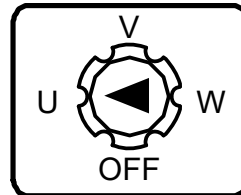

Figure 23. AC Ammeter
Change-Over Switch

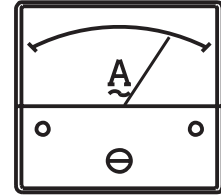

Figure 24. AC Ammeter
(Amp Reading On U Lug)

NOTICE

The **ammeter** gauge will only show a reading when the **output terminal lugs** are connected to a load and in use.

OUTPUT TERMINAL PANEL CONNECTIONS

UVWO TERMINAL OUTPUT VOLTAGES

Various output voltages can be obtained using the UVWO output terminal lugs. The voltages at the terminals are dependent on the position of the voltage selector switch and the adjustment of the voltage regulator.

Remember the voltage selector switch determines the range of the output voltage. The voltage regulator (VR) allows the user to increase or decrease the selected voltage.

NOTICE

ALWAYS make sure that the connections to the UVWO terminals are **secure** and **tight**. The possibility exists of arcing that could cause a fire. Torque tie bolts to 554.9 lbf·in (62.7 N·m).

3Ø-240V UVWO Terminal Output Voltages

1. Place the voltage selector switch in the 3Ø 240/139V position as shown in Figure 25.

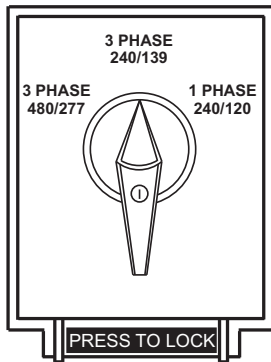

**Figure 25. Voltage Selector Switch
3Ø-240/139V Position**

2. Connect the load wires to the UVWO terminals as shown in Figure 26.

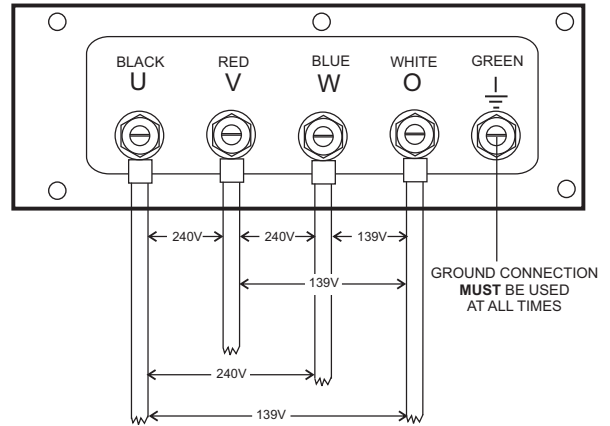

**Figure 26. UVWO Terminal Lugs
3Ø-240V/1Ø-139V Connections**

3. Turn the voltage regulator (Figure 27) clockwise to increase voltage output, and turn counterclockwise to decrease voltage output. Use the voltage regulator whenever fine tuning of the output voltage is required.



Figure 27. Voltage Regulator

3Ø-208V/1Ø-120V UVWO Terminal Output Voltages

1. Place the voltage selector switch in the 3Ø 240/139V position as shown in Figure 25.
2. Connect the load wires to the UVWO terminals as shown in Figure 28.

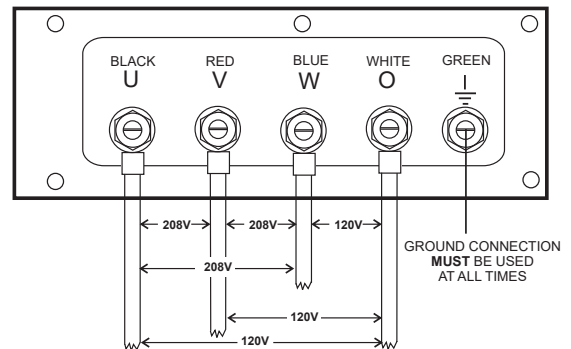

**Figure 28. UVWO Terminal Lugs
3Ø-208/1Ø-120V Connections**

OUTPUT TERMINAL PANEL CONNECTIONS

NOTICE

To achieve a 3Ø 208V output the voltage selector switch must be in the 3Ø-240/139V position and the voltage regulator must be adjusted to 208V.

3Ø-480/277V UVWO Terminal Output Voltages

1. Place the voltage selector switch in the 3Ø 480/277V position as shown in Figure 29.

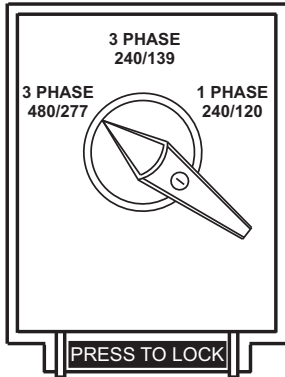

**Figure 29. Voltage Selector Switch
3Ø-480/277V Position**

2. Connect the load wires to the UVWO terminals as shown in Figure 30.

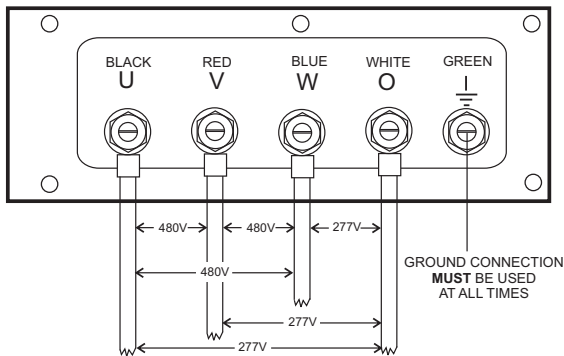

**Figure 30. UVWO Terminal Lugs 3Ø-480V
Connections**

1Ø-240/120V UVWO Terminal Output Voltages

1. Place the voltage selector switch in the 1Ø 240/120V position as shown in Figure 31.

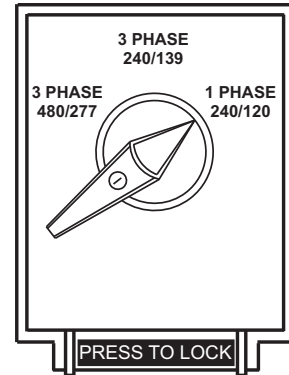

**Figure 31. Voltage Selector Switch
1Ø-240/120V Position**

2. Connect the load wires to the UVWO terminals as shown in Figure 32.

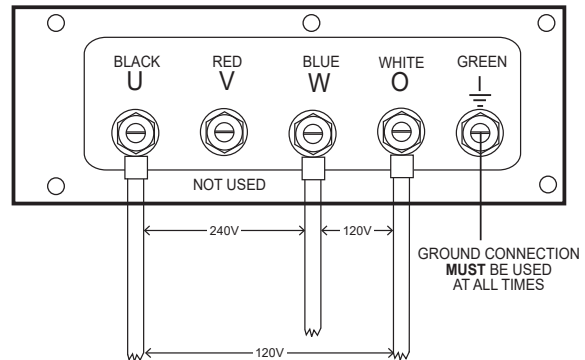

**Figure 32. UVWO Terminal Lugs
1Ø-240/120V Connections**

3. Turn the voltage regulator (Figure 27) clockwise to increase voltage output, turn counterclockwise to decrease voltage output. Use the voltage regulator whenever fine tuning of the output voltage is required.

ENGINE OIL CHECK

1. To check the engine oil level, place the generator on secure, level ground with the engine stopped.
2. Remove the dipstick from its holder (Figure 33) and wipe it clean.

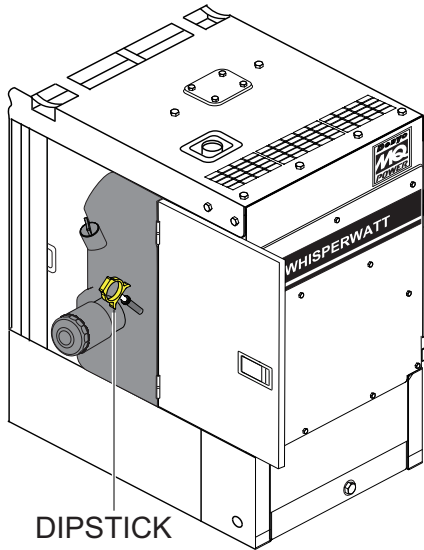

Figure 33. Engine Oil Dipstick

3. Reinsert the dipstick, then remove the dipstick from its holder. Check the oil level shown on the dipstick (Figure 34).

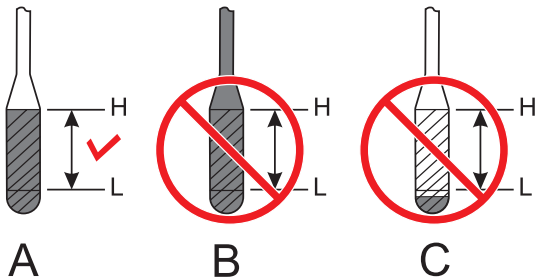

Figure 34. Engine Oil Dipstick

4. Verify that the engine oil level is maintained between the H and L markings on the dipstick as referenced in Figure 34.
5. If the engine oil level is low (Figure 34C), remove the cap from the oil filler port (Figure 35) and fill to a safe operating level (max) as indicated by the dipstick (Figure 34A). Fill with recommended type oil as listed in Table 12. Maximum oil capacity is 6.0 gallons (22.9 liters).

NOTICE

When adding engine oil **DO NOT** overfill (Figure 34B).

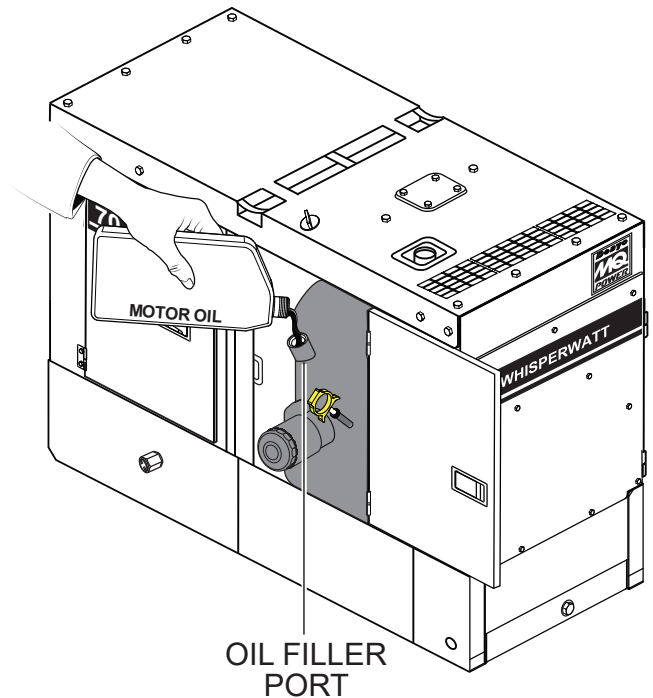
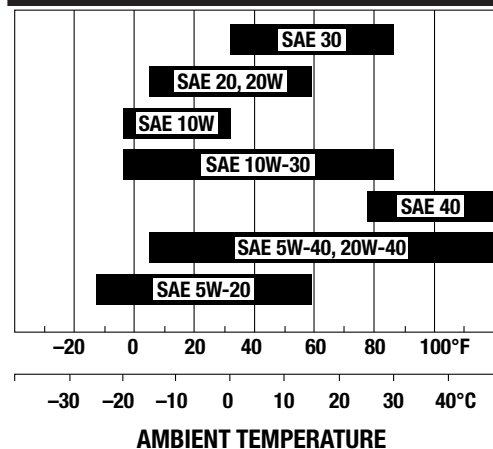

Figure 35. Engine Oil Filler Port

6. When checking the engine oil, be sure to check if the oil is clean. If the oil is not clean, drain the oil as described in the Maintenance section of this manual.
7. Allow enough time for any added oil to make its way to the oil pan before rechecking.

Table 12. Recommended Motor Oil



FUEL CHECK

DANGER



Fuel spillage on a **hot** engine can cause a **fire** or **explosion**. If fuel spillage occurs, wipe up the spilled fuel completely to prevent fire hazards. **NEVER** smoke around or near the generator. Make sure engine is **OFF** before refueling.

NOTICE

ALWAYS check the DEF tank level when adding fuel.

Refilling The Fuel System

NOTICE

DO NOT refuel while the engine is running.

CAUTION

ONLY properly trained personnel who have read and understand this section should refill the fuel tank system.

ALWAYS fill the fuel tank (Figure 36) with clean, fresh, #2 diesel fuel. **DO NOT** fill the fuel tank beyond its capacity.

Pay attention to the fuel tank capacity when replenishing fuel. The fuel tank cap must be closed tightly after filling. Handle fuel in a safety container. If the container does not have a spout, use a funnel. Wipe up any spilled fuel immediately.

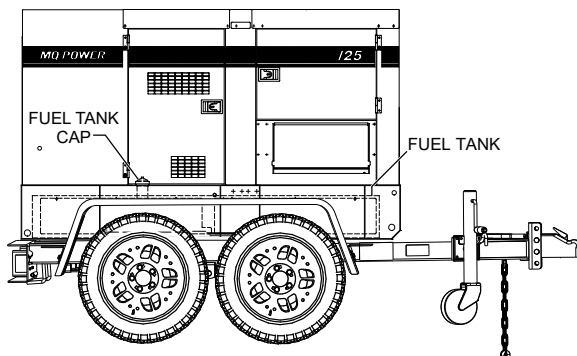

Figure 36. Fuel Tank

Refueling Procedure

WARNING



Diesel fuel and its vapors are dangerous to your health and the surrounding environment. Avoid skin contact and/or inhaling fumes.

1. **Level Tanks** — Make sure fuel cells are level with the ground. Failure to do so will cause fuel to spill from the tank before reaching full capacity (Figure 37).

CAUTION

ALWAYS place the trailer on firm, level ground before refueling to prevent spilling and maximize the amount of fuel that can be pumped into the tank.

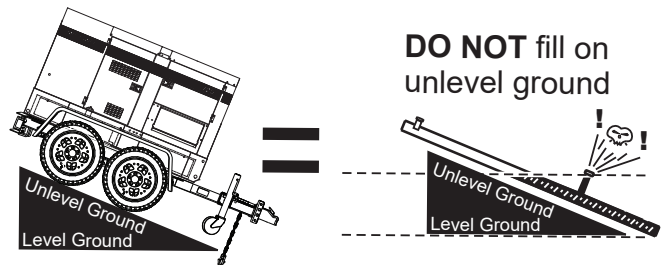

Figure 37. Only Fill On Level Ground

NOTICE

ONLY use #2 diesel fuel when refueling.

2. Open cabinet doors on the “right side” of the generator (from the generator control panel position). Remove the fuel cap and fill the tank (Figure 38).

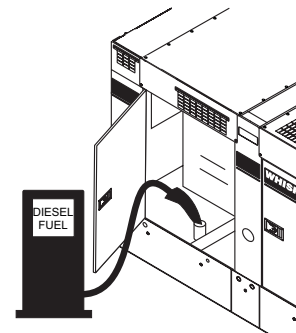

Figure 38. Fueling The Generator

3. **NEVER overfill the fuel tank** — It is important to read the fuel gauge when filling the fuel tank. **DO NOT** wait for fuel to rise in the filler neck (Figure 39).

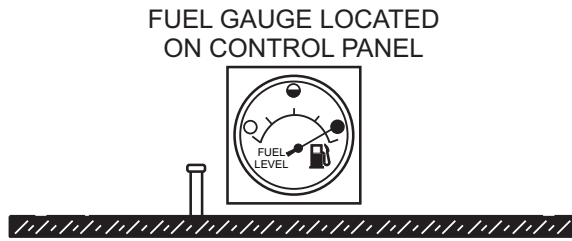

Figure 39. Full Fuel Tank

CAUTION

DO NOT OVERFILL the fuel system. Leave room for fuel expansion. Fuel expands when heated (Figure 40).

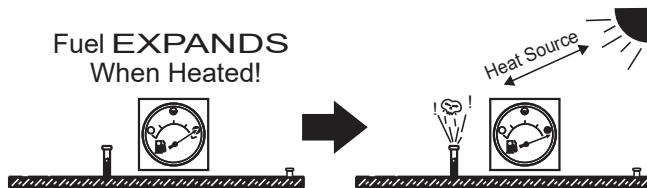

Figure 40. Fuel Expansion

DEF Refueling

NOTICE

ONLY fill the DEF tank with **diesel exhaust fluid**. Any other type of fluid may cause severe engine damage.

Diesel exhaust fluid (DEF) is an aqueous solution made with 32.5% high-purity urea (carbamide) and 67.5% deionized water. DEF is used as a consumable in **selective catalytic reduction (SCR)** in order to lower NO_x concentration from diesel exhaust emissions.

1. Make the sure engine is **OFF**.
2. Remove the filler cap from the DEF tank (Figure 41).

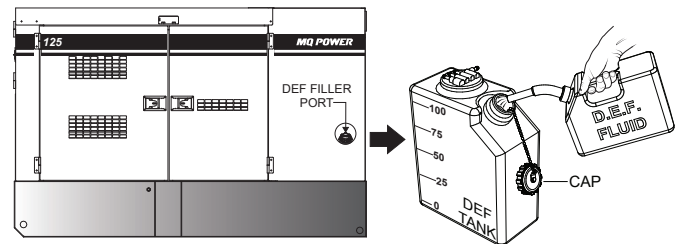

Figure 41. DEF Tank Filling

3. Upon initial start-up, **completely fill** the DEF tank with DEF fluid. **DO NOT** overfill.

DEF Refueling (Continuous Operation)

It is recommended to **shut down the engine** prior to refilling the DEF tank. However, in special applications where shutdown is not possible, it is recommended to **ONLY** refill the DEF tank when the fluid level has been consumed down to 50%.

The DEF level sending unit requires a gradual DEF level decrease during continuous operation to validate proper operation. Failure of this sensor to report the decrease could result in an engine shutdown. An engine service technician would be required to remedy the shutdown.

COOLANT (ANTIFREEZE/SUMMER COOLANT/WATER)

Isuzu recommends antifreeze/summer coolant for use in their engines, which can be purchased in concentrate (and mixed with 50% demineralized water) or pre-diluted. See the Isuzu Engine Owner's Manual for further details.

WARNING



If adding coolant/antifreeze mix to the radiator, **DO NOT** remove the radiator cap until the unit has completely cooled. The possibility of **hot!** coolant exists which can cause severe burns.

Day-to-day addition of coolant is done from the reserve tank. When adding coolant to the radiator, **DO NOT** remove the radiator cap until the unit has completely cooled. See Table 13 for engine, radiator, and reserve tank coolant capacities.

NOTICE

Normally, only the coolant level in the reserve tank needs to be checked. However, the radiator cap should be opened once a week to verify that coolant is visible (full) inside the radiator.

Verify that the coolant level in the coolant reserve tank is between the **FULL** and **LOW** markings as shown in Figure 42.

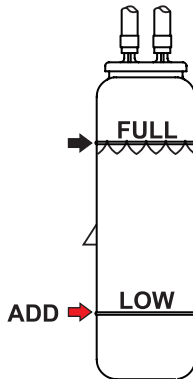

Figure 42. Coolant Reserve Tank

Table 13. Coolant Capacity	
Engine and Radiator	10.3 gal. (39.0 liters)
Reserve Tank	1.33 gal. (5.0 liters)

Operation In Freezing Weather

When operating in freezing weather, be certain the proper amount of antifreeze (Table 14) has been added.

Table 14. Coolant Capacity		
Climate	Outside Temperature	Longlife Coolant Concentration
Warm	10°F (-12°C) or Above	30%
Cold	-22°F (30°C) or Above	50%

Cleaning The Radiator

The engine may overheat if the radiator cooling fins (Figure 43) become overloaded with dust or debris. Periodically clean the radiator fins with compressed air. Cleaning inside the machine is dangerous, so clean only with the engine turned off and the negative battery terminal disconnected.

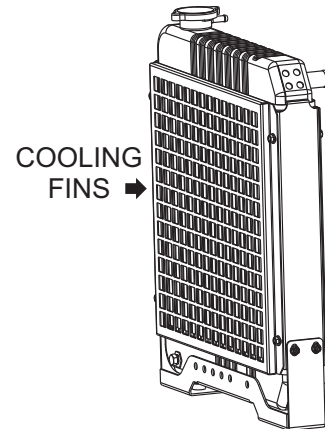

Figure 43. Radiator (Cooling Fins)

ENGINE AIR CLEANER

Periodic cleaning/replacement of the air cleaner is necessary. Inspect the air cleaner (Figure 44) in accordance with the maintenance section of this manual or the Isuzu Engine Owner's Manual.

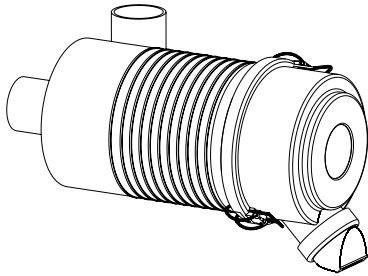

Figure 44. Engine Air Cleaner

FAN BELT TENSION

A slack fan belt may contribute to overheating, or to insufficient charging of the battery. Inspect the fan belt for damage and wear and adjust it in accordance with the Isuzu Engine Owner's Manual. The fan belt tension is proper if the fan belt bends 0.2–0.3 in. (6–8 mm) when pressed with the thumb as shown in Figure 45.

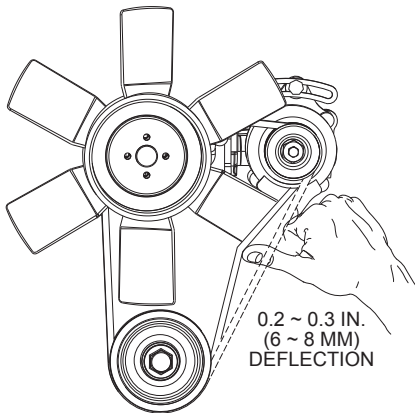

Figure 45. Fan Belt Tension

Standard Value Amount of Deflection	Standard Value (Vibration Frequency)
0.2–0.3 in. (6–8 mm)	210 Hz

CAUTION



NEVER place hands near the belts or fan while the generator set is running.

BATTERY

This unit is of negative ground. **DO NOT** connect in reverse. Always maintain battery fluid level between the specified marks. Battery life will be shortened if the fluid levels are not properly maintained. Add only distilled water when replenishment is necessary.

DO NOT overfill. Check to see whether the battery cables are loose. Poor contact may result in poor starting or malfunctions. **ALWAYS** keep the terminals firmly tightened. Coat the terminals with an approved battery terminal treatment compound. Replace the battery with only the recommended type battery. The battery type used in this generator is BCI Group 4D.

The battery is sufficiently charged if the specific gravity of the battery fluid is 1.28 (at 68°F). If the specific gravity should fall to 1.245 or lower, it indicates that the battery is dead and needs to be recharged or replaced.

Before charging the battery with an external electric source, be sure to disconnect the battery cables.

Battery Cable Installation

ALWAYS be sure the battery cables (Figure 46) are properly connected to the battery terminals as shown below. The **red cable** is connected to the **positive** terminal of the battery, and the **black cable** is connected to the **negative** terminal of the battery.

CAUTION

ALWAYS disconnect the negative terminal **FIRST** and reconnect the negative terminal **LAST**.

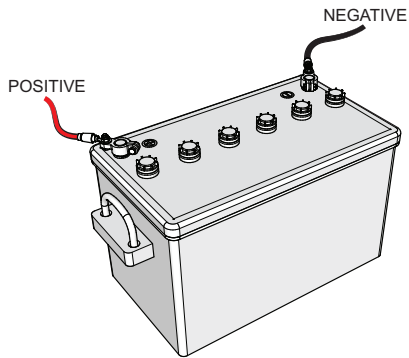

Figure 46. Battery Connections

When connecting the battery do the following:

1. **NEVER** connect the battery cables to the battery terminals when the **Auto Start/Stop switch** is in either the **AUTO** or **MANUAL** position. **ALWAYS** make sure that this switch is in the **OFF/RESET** position when connecting the battery.
2. Place a small amount of battery terminal treatment compound around both battery terminals. This will ensure a good connection and will help prevent corrosion around the battery terminals.

NOTICE

If the battery cable is connected incorrectly, electrical damage to the generator will occur. Pay close attention to the polarity of the battery when connecting the battery.

CAUTION

Inadequate battery connections may cause poor starting of the generator, and create other malfunctions.

ALTERNATOR

The polarity of the alternator is negative grounding type. When an inverted circuit connection takes place, the circuit will be in short circuit instantaneously, resulting in alternator failure.

DO NOT put water directly on the alternator. Entry of water into the alternator can cause corrosion and damage the alternator.

WIRING

Inspect the entire generator for bad or worn electrical wiring or connections. If any wiring or connections are exposed (insulation missing) replace wiring immediately.

PIPING AND HOSE CONNECTIONS

Inspect all piping, oil hose, and fuel hose connections for wear and tightness. Tighten all hose clamps and check hoses for leaks.

If any fuel or oil hose lines are defective, replace them immediately.

GENERATOR START-UP PROCEDURE (MANUAL)

BEFORE STARTING

CAUTION

The engine's exhaust contains harmful emissions. **ALWAYS** have adequate ventilation when operating. Direct exhaust away from nearby personnel.

WARNING

NEVER manually start the engine with the **main, GFCI or auxiliary** circuit breakers in the **ON** (closed) position.

- Place the **main, auxiliary, and GFCI** circuit breakers (Figure 47) in the **OFF** position prior to starting the engine.

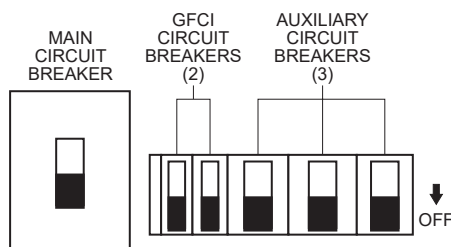

Figure 47. Main, Auxiliary, And GFCI Circuit Breakers (OFF)

- Make sure the voltage selector switch has been configured for the desired output voltage.
- Connect the load to the **receptacles, output terminal lugs**, or optional **cam-loks** as shown in Figure 15. These load connection points can be found on the output terminal panel and the output terminal panel's hard wire hookup panel.

NOTICE

ALWAYS make sure that the connections to the UVWO terminals are **secure** and **tight**. The possibility exists of arcing that could cause a fire. Torque tie bolts to 554.9 lbf·in (62.7 N·m).

- Close all engine enclosure doors (Figure 48).

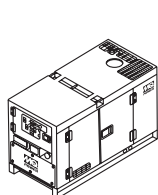

CORRECT

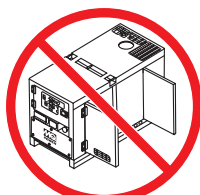

INCORRECT

Figure 48. Engine Enclosure Doors

STARTING (MANUAL)

- Place the **Engine Speed** switch in the **LOW** position (Figure 49).



Figure 49. Engine Speed Switch (Low Position)

- To start the engine, place the **Auto Start/Stop** switch in the **MANUAL** position (Figure 50).



Figure 50. Auto Start/Stop Switch (Manual Position)

NOTICE

If the engine fails to start within three attempts, the Shutdown lamp will illuminate and the Auto Start/Stop switch must be placed in the Off/Reset position before the next attempt.

NOTICE

The engine will pre-heat automatically in cold weather conditions. "Glow Plug Hold" message will be displayed and the engine will start automatically after pre-heating.

- Once the engine starts, let the engine run for 1–2 minutes to warm up. For operation in below-freezing weather temperatures, this warmup period must be extended to 5–7 minutes. During the warmup period, check for any abnormal noise, vibration, or fluid leakage. Check the gauges on the control panel. If any abnormalities exist, shut down the engine and correct the problem.
- After the warmup process has completed, place the **Engine Speed** switch in the **HIGH** (up) position. The engine speed will increase to 1,800 rpm and the unit is now ready for operation.



Figure 51. Engine Speed Switch (High Position)

GENERATOR START-UP PROCEDURE (MANUAL)

5. The generator's **frequency meter** (Figure 52) should be displaying the 60-cycle output frequency in **HERTZ**.

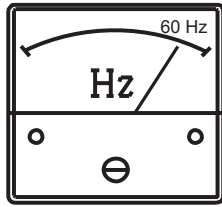

Figure 52. Frequency Meter

6. The generator's **AC voltmeter** (Figure 53) will display the generator's output in **VOLTS**.

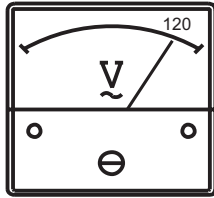

Figure 53. Voltmeter

7. If the voltage is not within the specified tolerance, use the **voltage regulator** (Figure 54) to increase or decrease the desired voltage.

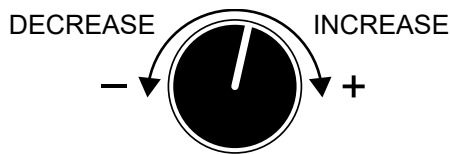

Figure 54. Voltage Regulator

8. The **ammeter** (Figure 55) will indicate **zero amps** with no load applied. When a load is applied, the ammeter will indicate the amount of current that the load is drawing from the generator.

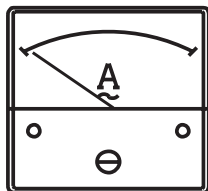

Figure 55. Ammeter (No Load)

9. The **engine oil pressure gauge** (Figure 56) will indicate the oil pressure of the engine. Under normal operating conditions the oil pressure should be between 42.1 and 85.6 psi (290–590 kPa). When starting the generator the oil pressure may read a little higher, but after the engine warms up the oil pressure should return to the correct pressure range.

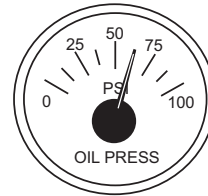

Figure 56. Oil Pressure Gauge

10. The **coolant temperature gauge** (Figure 57) will indicate the coolant temperature. Under normal operating conditions the coolant temperature should be between 167°–194°F (75°–90°C).

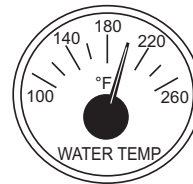

Figure 57. Coolant Temperature Gauge

11. The **tachometer** (Figure 58) will indicate the speed of the engine in **RPM**. Under normal operating conditions this speed is approximately 1,800 rpm.

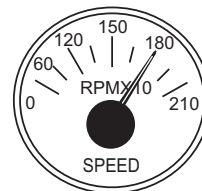

Figure 58. Engine Tachometer

GENERATOR START-UP PROCEDURE (MANUAL)

12. Place the **main, auxiliary, and GFCI** circuit breakers in the **ON** position (Figure 59).

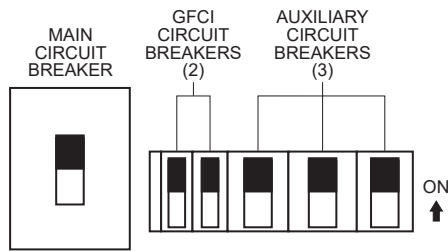

Figure 59. Main, Auxiliary, And GFCI Circuit Breakers (ON)

13. Observe the generator's ammeter (Figure 60) and verify it reads the anticipated amount of current with respect to the load. The ammeter will only display a current reading if a load is in use.

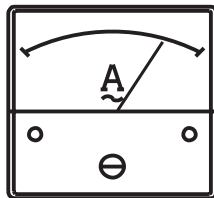

Figure 60. Ammeter (Load)

14. The generator will run until manually stopped or an abnormal condition occurs.

GENERATOR START-UP PROCEDURE (AUTO MODE)

STARTING (AUTO MODE)

DANGER



Before connecting this generator to any building's electrical system, a **licensed electrician** must install an **isolation (transfer) switch**. Serious damage to the building's electrical system may occur without this transfer switch.

NOTICE

When connecting the generator to an isolation (transfer) switch, **ALWAYS** have power applied to the generator's internal battery charger. This will ensure that the engine will not fail due to a dead battery.

NOTICE

When the generator is set to **AUTO** mode, the generator will **automatically start** in the event of commercial power falling below a prescribed level by means of a contact closure that is generated automatically by a transfer switch.

WARNING

When operating the generator in **AUTO** mode, remember that the generator can start up at any time without warning. **NEVER** attempt to perform any maintenance while the generator is in Auto mode.

CAUTION

The Engine Speed switch **must** be set to the **High position** when running in **Auto mode**. Failing to set the switch in the proper position can result in damage to the generator when it turns on.

NOTICE

When the **Auto Start/Stop switch** is placed in the **AUTO** position, the engine glow plugs will be warmed and the engine will start automatically.

NOTICE

The battery charger option can only be operated when the generator is in Manual Start mode.

1. Perform steps 1–4 under **Before Starting** in the **Generator Start-Up Procedure (Manual)** section.
2. Place the **Engine Speed switch** in the **HIGH** position (Figure 61).



Figure 61. Engine Speed Switch (High Position)

3. Place the **Auto Start/Stop switch** (Figure 62) in the **AUTO** position.



Figure 62. Auto Start/Stop Switch (Auto Position)

4. Once the start signal is received (the remote-start contacts are closed), the pre-heating process will begin. When the pre-heating process has completed, the engine will start automatically and accelerate to rated speed. When the remote-start contacts are opened, the engine will stop.
5. If the engine fails to start, perform the manual starting procedure.

GENERATOR SHUTDOWN PROCEDURE

NORMAL SHUTDOWN PROCEDURE

WARNING

NEVER stop the engine suddenly except in an emergency.

To shut down the generator, use the following procedure:

1. Place the load's ON/OFF switch in the **OFF** position.
2. Place the **main, auxiliary, and GFCI** circuit breakers (Figure 63) in the **OFF** position.

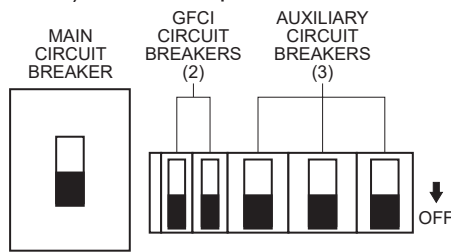

Figure 63. Main, Auxiliary, And GFCI Circuit Breakers (OFF)

3. Place the **Engine Speed switch** in the **LOW** position (Figure 64).



Figure 64. Engine Speed Switch (Low Position)

4. Let the engine cool by running it at low speed for 3–5 minutes with no load applied.
5. Place the **Auto Start/Stop switch** (Figure 65) in the **OFF/RESET** position.

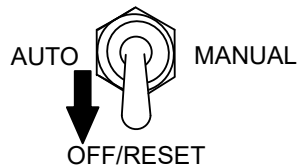

Figure 65. Auto Start/Stop Switch (Off/Reset Position)

NOTICE

DO NOT disconnect the battery cables immediately after the engine stops. Wait for at least 2–3 minutes before disconnecting the battery cables.

6. Allow adequate time for cooling, then inspect the entire generator for any damage or loosening of components that may have occurred during operation.

EMERGENCY SHUTDOWN PROCEDURE

NOTICE

The Emergency Stop switch should only be used to stop the engine in case of an emergency or to lock out operation during service. The emergency stop switch should **NEVER** be used for routine stopping of the engine.

1. To stop the engine in the event of an emergency, press the **Emergency Stop switch** (Figure 66), located on the side of the generator next to the output terminal panel.

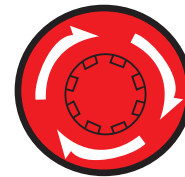

Figure 66. Emergency Stop Switch

2. Place the **main, auxiliary, and GFCI circuit breakers** in the **OFF** position as shown in Figure 63.
3. The Emergency Stop switch is a push-locked type switch. The switch contact can only be released by rotating the button in the clockwise direction. The engine cannot be restarted until the contact is released (closed).

AUTOMATIC SHUTDOWN SYSTEM

This unit is equipped with safety devices to automatically stop the engine in the event of low oil pressure (approximately 14.2 psi/97.9 kPa), high water temperature (approximately 212°F/100°C), overspeed (approximately +15%), or low coolant level. The Shutdown lamp on the controller will illuminate and diagnostic trouble codes will be displayed to signify the reason for the shutdown.

NOTICE

Before inspecting the generator after an automatic shutdown, place the Auto Start/Stop switch in the **OFF/RESET** position, and place all circuit breakers in the **OFF** position. Allow adequate time for cooling before troubleshooting. When all faults have been cleared, restart the engine according to the **Generator Startup Procedure** section of this manual.

MAINTENANCE

Table 16. Inspection/Maintenance		Daily	Every 250 Hours	Every 500 Hours	Every 1,000 Hours	Other
Engine	Check Engine Oil and Coolant Levels	X				
	Check Fuel Filter / Water Bowl	X				
	Check Battery Fluid Level	X				
	Check Air Cleaner	X				
	Check for Leaks	X				
	Visual Walk-Around Inspection	X				
	Clean Air Cleaner Element		X			
	Replace Engine Oil and Oil Filter* ¹		(X)	X		
	Replace Fuel Filter Elements		(X)	X		
	Check Fan Belt Condition			X		
	Check Electrical Ground Connection			X		
	Clean Radiator and Check Cooling System			X		
	Check and Adjust Engine Valve Clearance				X	
	Clean Inside Fuel Tank				X	
	Check All Hoses and Clamps				X	
	Check Engine Mounts			X		
	Replace Air Cleaner Elements* ²				X	
	Replace DEF Filter (in Supply Module)					3,000 hours
	Check SCR System* ³					4,500 hours
Inspect Dosing Module (SRC System)* ³					4,500 hours	
Flush and Refill Cooling System* ⁴					1 year or 2,000 hours	
Generator	Measure Insulation Resistance Over 3M Ohms* ⁵		X			
	Check Rotor Rear Support Bearing			X		

*¹ During the initial operation of a new engine, change oil and filter between a minimum of 100 hours and a maximum of 250 hours. Service interval depends on oil type.

*² Replace air cleaner element when restriction indicator shows a vacuum of 635 mm (25 in. H₂O).

*³ Perform inspection and maintenance of DEF in the SCR system every 4,500 hours. The system does not need to be replaced/exchanged if no problem is detected. Do not make any modification or changes nor remove the emission control system's related parts. Please contact your nearest dealer or the Multiquip Service Department for SCR maintenance.

*⁴ Use fully formulated antifreeze/coolant.

*⁵ Make sure to disconnect the O – Earth line and CN11 – CN12 before performing the measurement. Refer to the **Generator Wiring Diagram**.

GENERAL INSPECTION

Prior to each use, the generator should be cleaned and inspected for deficiencies. Check for loose, missing or damaged nuts, bolts or other fasteners. Also check for fuel, oil, and coolant leaks. Use Table 16 as a general inspection and maintenance guideline. For more detailed engine maintenance instructions, refer to the engine owner's manual.

ENGINE AIR CLEANER

This Isuzu diesel engine is equipped with a replaceable, high-density, paper air cleaner element (Figure 67). The air cleaner is also equipped with an inner (secondary) element that is used as a backup filter should the primary element become damaged. Check the air cleaner daily or before starting the engine. Replace the air cleaner as needed.

NOTICE

If the engine is operating in very dusty or dry grass conditions, a clogged air cleaner will result. This can lead to a loss of power, excessive carbon buildup in the combustion chamber, and high fuel consumption. Change the air cleaner more frequently if these conditions exist.

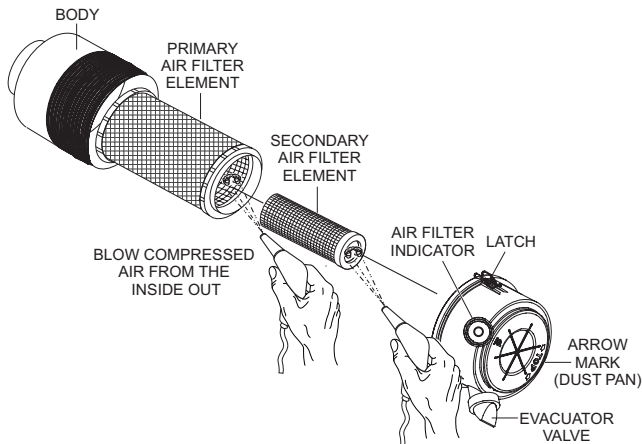

Figure 67. Engine Air Cleaner

Primary And Secondary Air Cleaner Elements

Every 250 hours: Remove the air cleaner elements and clean them with a light spray of compressed air.

CAUTION



Wear protective equipment such as approved safety glasses or face shields and dust masks or respirators when cleaning air filters with compressed air.

1. Release the latches that secure the cover to the air cleaner body (Figure 67).
2. Remove the air cleaner cover (Figure 67) and set it aside.
3. Remove both the primary and secondary air cleaner elements (Figure 67).
4. Check for and correct heavy buildup of dirt and debris along with loose or damaged components.

NOTICE

Operating the engine with loose or damaged air cleaner components could allow unfiltered air into the engine causing premature wear and failure.

5. To clean the primary element (paper air filter) as shown in Figure 67, tap the filter element several times on a hard surface to remove dirt, or blow compressed air, not to exceed 30 psi (207 kPa, 2.1 kgf/cm²), through the filter element from the inside out.
6. Clean the secondary element (paper air filter) as described in step 5.
7. Replace both elements if they are damaged or excessively dirty.
8. Clean the inside of the air cleaner body (Figure 67).
9. Reinstall the primary and secondary air filter elements back into the air cleaner body.
10. Reinstall the air cleaner cover and secure with latches.

NOTICE

DO NOT run the engine with the air cleaner removed or without an element.

Air Cleaner Restriction Indicator

The air cleaner is equipped with a restriction indicator (Figure 68). As the air cleaner element becomes clogged, air intake restriction increases and the indicator signal shows **RED**, indicating that the element needs to be replaced. After replacing the air cleaner element, press the restriction indicator button to reset the indicator.

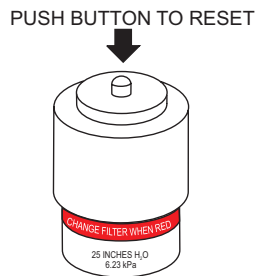

Figure 68. Air Cleaner Restriction Indicator

NOTICE

The air cleaner element should not be changed until the indicator displays **RED**. Dispose of the old element. It cannot be cleaned or reused.

ENGINE FUEL FILTER

Inspect the engine fuel filter daily. If the fuel filter has collected a significant amount of water and sediment at the bottom of the cup, it should be drained off immediately.

Draining The Fuel Filter

1. Loosen the air bleeder plug (Figure 69) on the fuel filter body.
2. To discharge the fuel inside the fuel filter, **OPEN** the drain valve on the fuel filter by turning the knob **counterclockwise** (Figure 69A) approximately 3-1/2 turns until the valve drops down 1 inch (25.4 mm) and draining occurs (Figure 69B).

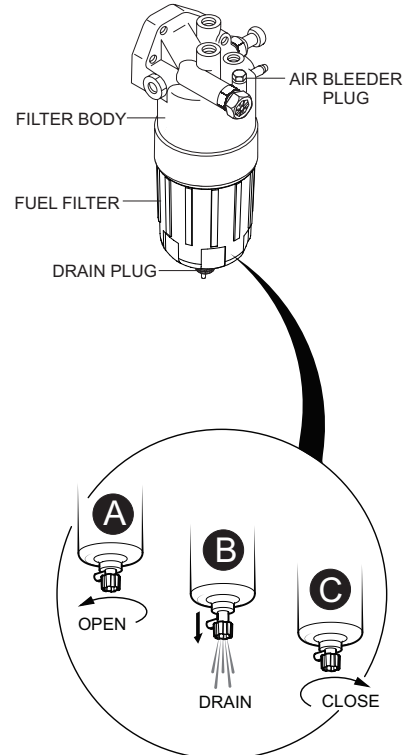

Figure 69. Draining The Fuel Filter

3. Let the residue or foreign substances inside the case flow into a suitable container.
4. At completion of draining, **CLOSE** the drain valve (Figure 69C).

Fuel Filter Element Replacement

1. Use a filter wrench to remove the element case (Figure 70) from the fuel filter body.

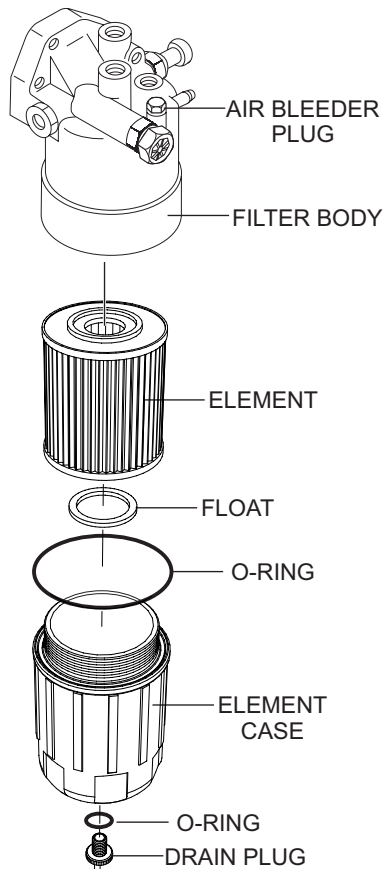

Figure 70. Fuel Filter Replacement

2. Wipe the inside of the filter body with a clean cloth to remove any foreign matter or debris that may have accumulated.
3. Insert the new fuel filter element into the element case.
4. Replace both O-rings. Coat each O-ring with a small amount of clean 15W-40 engine oil.
5. Reinstall the element case first by hand until it makes contact with the fuel filter body surface.
6. Torque the element case to 22.4 lbf-ft (30 N·m).
7. Torque the drain plug to 1.4 lb-ft (2.0 N·m).
8. Remove the air from the fuel system. Reference the Isuzu Owner's Manual, "Bleeding the Fuel System."

ELECTROMAGNETIC FUEL PUMP (500 HOURS)

The filter inside the fuel pump (Figure 71) is either a paper type or steel mesh type depending on fuel pump type. Clean or replace the fuel pump filter as follows:

1. Disconnect any electrical connections that are attached to the fuel pump.
2. Prepare a fuel collector to drain the fuel into. Secure any fuel lines to prevent fuel from spilling.
3. Remove the fuel pump from the generator enclosure.
4. Remove the filter and gasket from the fuel pump housing.

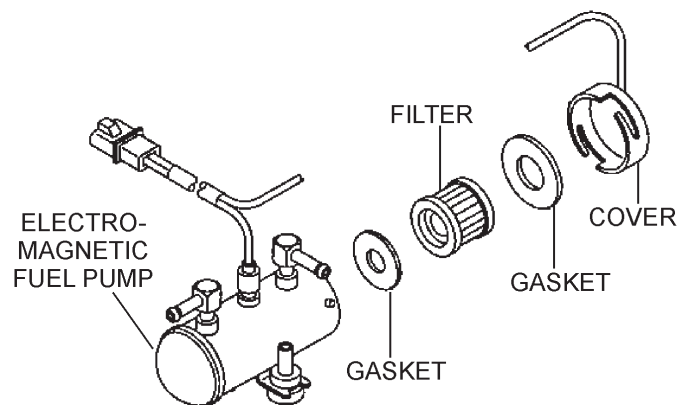

Figure 71. Electromagnetic Fuel Pump

NOTICE

When the fuel pump filter is removed, always make sure to replace both gaskets and clean the magnet portion inside the cover.

5. Clean or replace the fuel pump filter. Replace both gaskets.
6. Reassemble the fuel pump and mount it back onto the generator enclosure.
7. Reconnect all fuel lines and electrical components.
8. Check for fuel leaks.

DRAINING THE CONTAINMENT TANK

1. This generator is equipped with an environmental containment tank. Inspect this tank regularly.
2. If the tank becomes full with fluids, remove the drain bolt (Figure 72), then allow the fluids to drain into a suitable container.

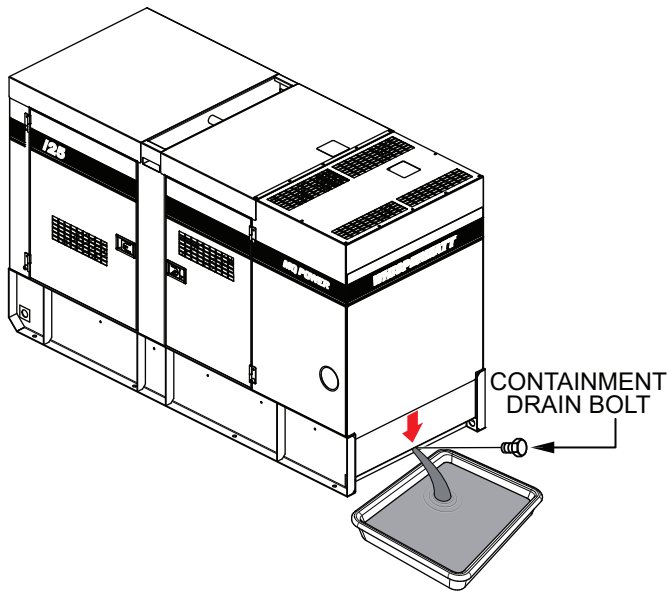

Figure 72. Draining The Containment Tank

CLEANING INSIDE THE FUEL TANK

If necessary, drain the fuel inside the fuel tank completely. Using a spray washer (Figure 73) wash out any deposits or debris that have accumulated inside the fuel tank.

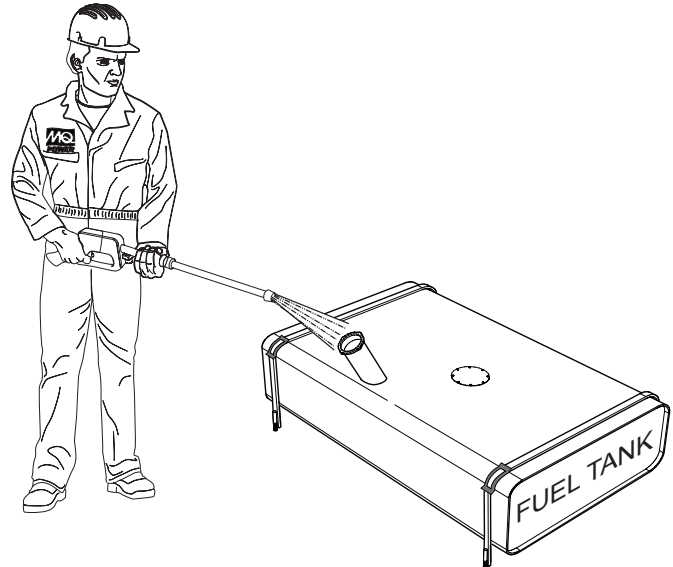

Figure 73. Fuel Tank Cleaning

FUEL TANK INSPECTION

In addition to cleaning the fuel tank, the following components should be inspected for wear:

- **Rubber Suspension** — Look for signs of wear or deformity due to contact with oil. Replace the rubber suspension if necessary.
- **Fuel Hoses** — Inspect nylon and rubber hoses for signs of wear, deterioration or hardening.
- **Fuel Tank Lining** — Inspect the fuel tank lining for signs of excessive amounts of oil or other foreign matter.

DRAINING THE ENGINE OIL

1. Run the engine until the engine coolant reaches a temperature of 140°F (60°C). Turn the engine off.
2. Remove the oil dipstick from its holder.
3. Remove the **oil drain cap** (Figure 74).
4. Place the **oil drain valve** in the **OPEN** position and allow the oil to drain into a suitable container.

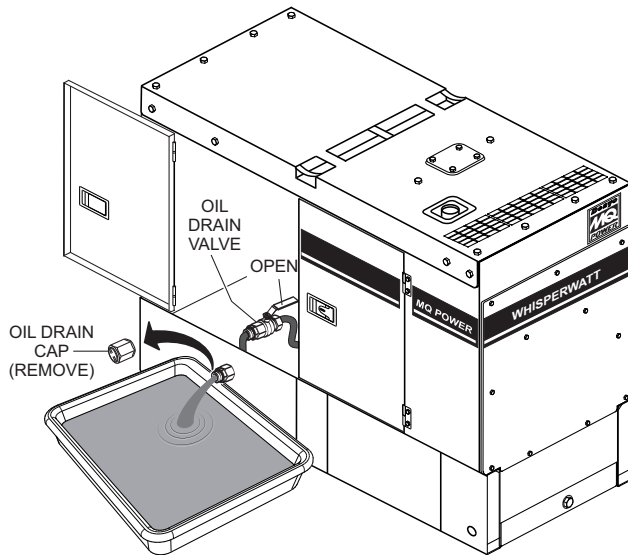

Figure 74. Draining The Engine Oil

5. After the engine oil has been completely drained, reinstall the oil drain cap and tighten securely.
6. Place the **oil drain valve** in the **CLOSED** position.

ENGINE OIL FILTER REPLACEMENT

1. Clean the area around the lubricating oil filter head.
2. Using an oil filter wrench (Figure 75), remove the engine oil filter.

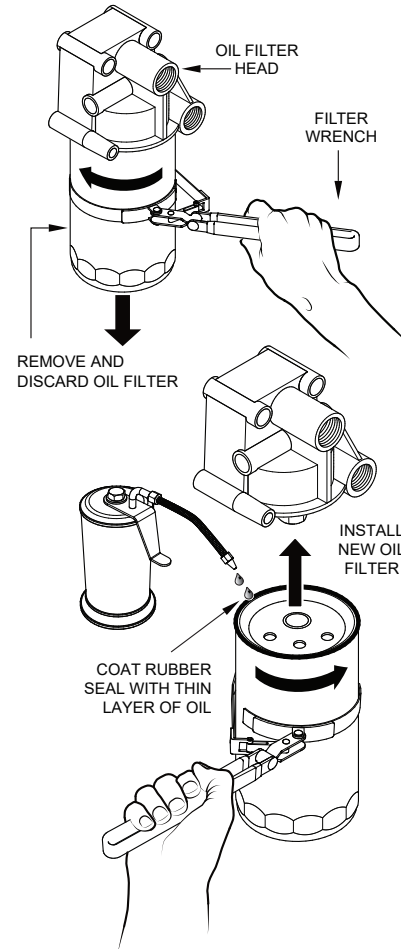

Figure 75. Oil Filter Removal

3. Coat the rubber seal (gasket) surface of the oil filter (Figure 75) with clean 15W-40 engine oil.
4. Install the new oil filter first by hand until it makes contact with the filter head surface. Tighten it another 3/4 turn using the filter wrench.
5. Fill the engine crankcase with high-quality detergent oil classified "For Service CI-4." Fill to the upper limit of the dipstick. **DO NOT** overfill. Reference Table 2 for engine crankcase oil capacity.
6. Run the engine for several minutes. Watch for oil leakage. Shut the engine down and allow it to sit for several minutes. Top off the oil to the upper limit on the dipstick.

DRAINING THE ENGINE COOLANT

WARNING



DO NOT remove the pressure cap from the radiator when the engine is hot! Wait until the coolant temperature is below 120°F (50°C) before removing the pressure cap. Heated coolant spray or steam can cause severe scalding and personal injury.

1. Remove the radiator pressure cap (Figure 76) only if the coolant temperature is below 120°F (50°C).

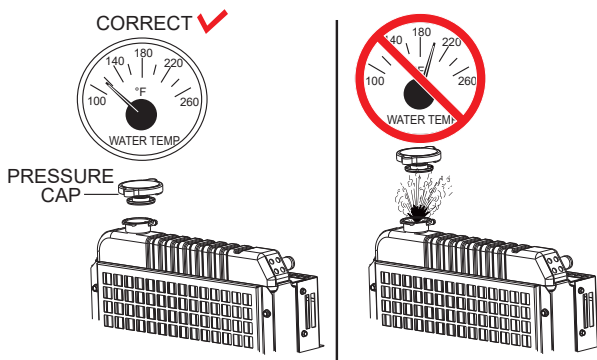

Figure 76. Radiator Pressure Cap Removal

2. Place the *coolant drain valve* in the **OPEN** position (Figure 77) and allow the coolant to drain into a suitable container.

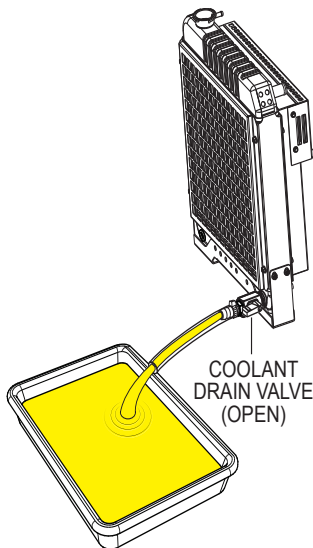

Figure 77. Draining The Engine Coolant

3. Flush out the radiator and replace the coolant. Refer to *Cleaning the Coolant Passages* and *Filling the Coolant System* in the Isuzu engine owner's manual.

WARNING



Allow the engine to **cool** when flushing out the radiator. Flushing the radiator while hot could cause serious burns from water or steam.

RADIATOR CLEANING

The radiator (Figure 78) should be sprayed (cleaned) with a high-pressure washer when excessive amounts of dirt and debris have accumulated on the cooling fins or tube. When using a high-pressure washer, stand at least 5 feet (1.5 meters) away from the radiator to prevent damage to the fins and tube.

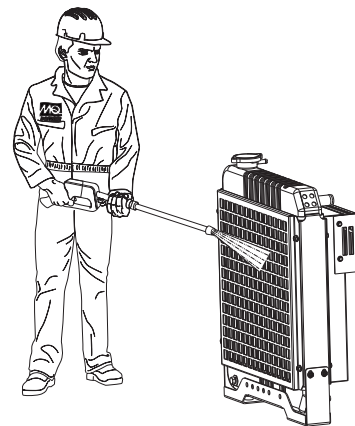

Figure 78. Radiator Cleaning

DRIVE BELT (DAILY)

Drive Belt Tension

A slack drive belt (Figure 79) may contribute to overheating or insufficient charging of the battery. Adjust the drive belt in accordance with the Isuzu Operator's manual.

Drive Belt Inspection

Inspect the drive belt for damage and wear. Horizontal cracks (across the belt) are acceptable. Vertical (direction of belt ribs) cracks that intersect with horizontal cracks are not acceptable.

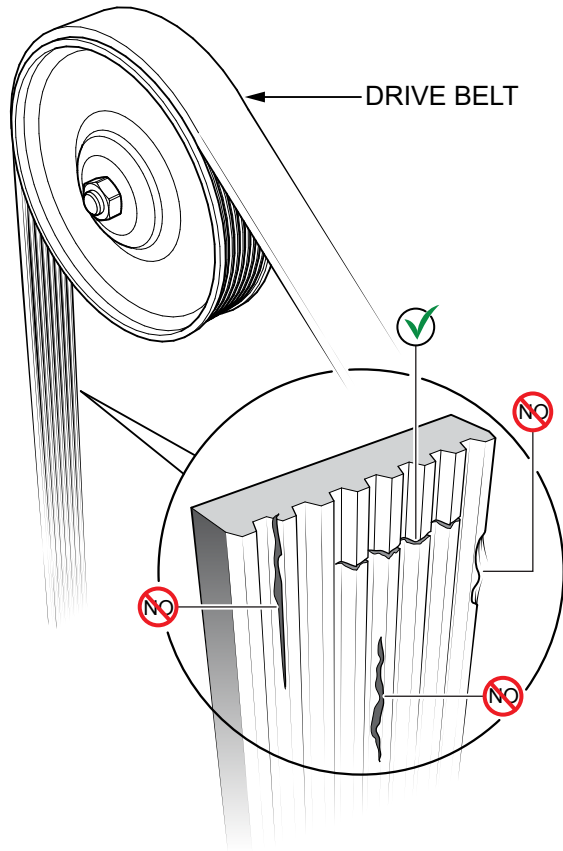

Figure 79. Drive Belt Inspection

Also, examine the belt and determine if it is **oil soaked** or **glazed** (a hard shiny appearance on the sides of the belt). Either of these two conditions can cause the belt to run hot, which can weaken it and increase the danger of it breaking.

If the drive belt exhibits any of the above wear conditions, replace the drive belt immediately.

TESTING THE GFCI RECEPTACLE

NOTICE

The GFCI receptacle is designed to interrupt power when a ground fault exists to prevent injuries and shock hazards. **DO NOT** use the GFCI receptacle if the test below fails. Consult a qualified electrician for repair or replacement of the GFCI receptacle. Test the GFCI receptacle **at least once a month**.

1. Start the generator as outlined in the start-up procedure in this manual.
2. Place a GFCI circuit breaker (Figure 80) in the **ON** position.

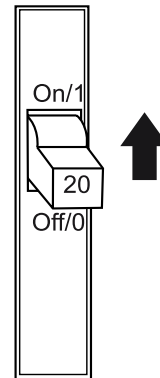

Figure 80. GFCI Circuit Breaker

3. Verify that the status LED on the corresponding GFCI receptacle (Figure 81) is **ON (GREEN)**.

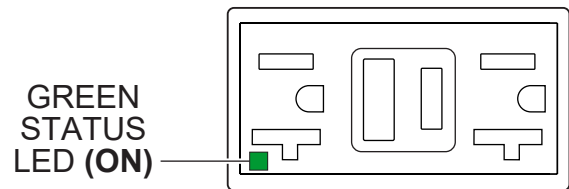

Figure 81. GFCI Receptacle (ON)

4. Press the **TEST** button (Figure 82) on the GFCI receptacle and verify that the status LED turns **OFF**.

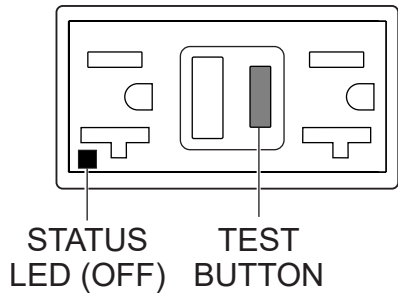

Figure 82. GFCI Receptacle (OFF)

5. Press the **RESET** button (Figure 83) to restore power to the GFCI receptacle and verify that the status LED is **ON (GREEN)**.

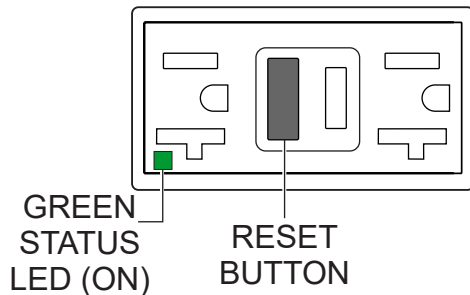

Figure 83. GFCI Receptacle (ON/Restore)

6. If the status LED (Figure 84) is **flashing (RED)**, **DO NOT** use the GFCI receptacle and replace it immediately.

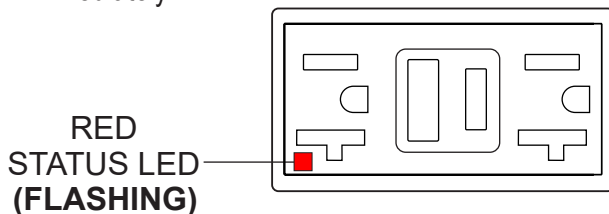

Figure 84. GFCI Receptacle (Red Flashing LED)

7. Repeat the above procedure for the other GFCI receptacle.

GENERATOR STORAGE

For long-term storage of the generator the following is recommended:

- Drain the fuel tank completely. Treat with a fuel stabilizer if necessary.
- Completely drain the oil from the crankcase and refill if necessary with fresh oil.
- Clean the entire generator, internal and external.
- Cover the generating set and store in a clean, dry place.
- Disconnect the battery.
- Make sure engine coolant is at the proper level.
- If the generator is mounted on a trailer, jack the trailer up and place it on blocks so the tires do not touch the ground, or block and completely remove the tires.

ENGINE BLOCK HEATER AND OPTIONAL INTERNAL BATTERY CHARGER 120 VAC INPUT RECEPTACLES

This generator comes equipped with an **engine block heater**. An **internal battery charger** is available as an **option**. These components are provided with electrical power cords to connect to a commercial power source.

The engine block heater and internal battery charger both require 120 VAC in order to operate. Two receptacles (Figure 85) have been provided on the output terminal panel to allow commercial power to be applied.

These units will **ONLY** function when commercial power has been supplied to them. When using extension cords, refer to Table 7 for the correct size and length.

When using the generator in **hot** climates there is no need to apply power to the engine block heater. However, if the generator will be used in **cold** climates, it is best to apply power to the engine block heater at all times.

If the generator will be used daily, the battery should normally not require charging. If the generator will be idle (not used) for long periods of time, apply power to the battery charger receptacle via commercial power using a power cord of adequate size.

NOTICE

If the generator will be idle (not used) for long periods of time and to ensure adequate starting capability, always have power applied to the generator's internal battery charger.

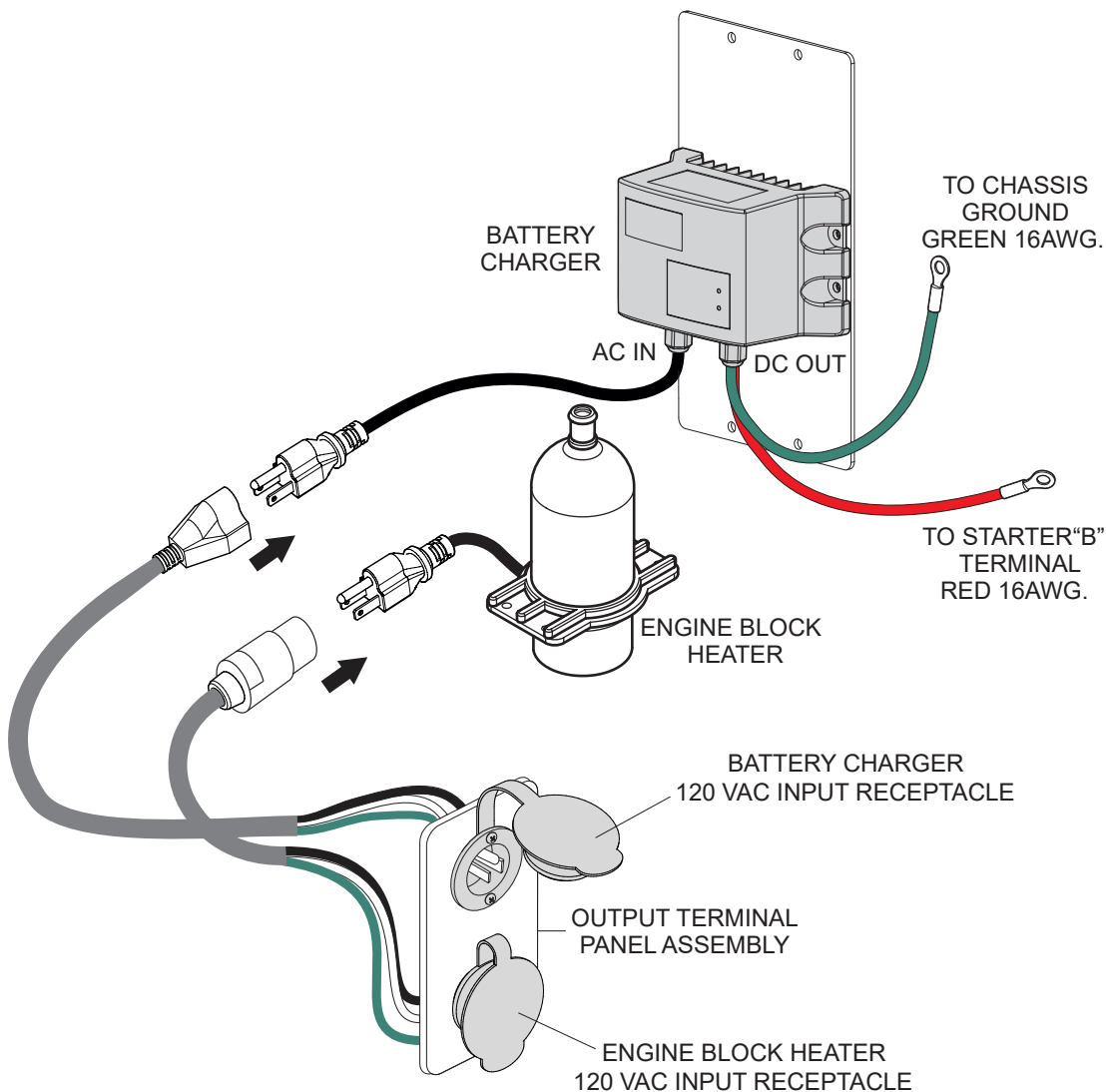

Figure 85. Engine Block Heater And Optional Battery Charger

EMISSION CONTROL

The emission control system employed with the Isuzu BR-4HK1X diesel engine consists of a Diesel Oxidation Catalyst (DOC).

This device oxidizes large amounts of harmful nitrogen oxides (NO_x) and particulate matter (PM) which are emitted by diesel engines. These exhaust emissions pose serious environmental and health risks. No maintenance or service is required for the DOC device used on this generator.

Diesel Oxidation Catalyst (DOC)

The DOC (Figure 86) does not filter particles, it oxidizes them. This catalyst (honeycomb-like structure) uses a chemical process to break down pollutants in the exhaust stream into less harmful components. In general this catalyst collects/burns accumulated particulates. The DOC contains palladium and platinum which serve as catalysts to oxidize hydrocarbons and carbon monoxide.

PREVENTIVE MAINTENANCE PROGRAMS

Most challenging to a rental organization is the fact that a customer's power assumptions may not meet the minimum load requirements of the power equipment selected. When in doubt, it is always recommended to apply a **load bank application** to the equipment following a longer rental period.

Equipment on extended, long-term contracts needs periodic on-site inspection. If possible, interview the operator and survey the equipment hooked up to the generator to estimate load conditions.

Preventive maintenance and a few extra steps prevent downtime and protect your investment and business. A well-planned preventive maintenance program will reward you with years of service.

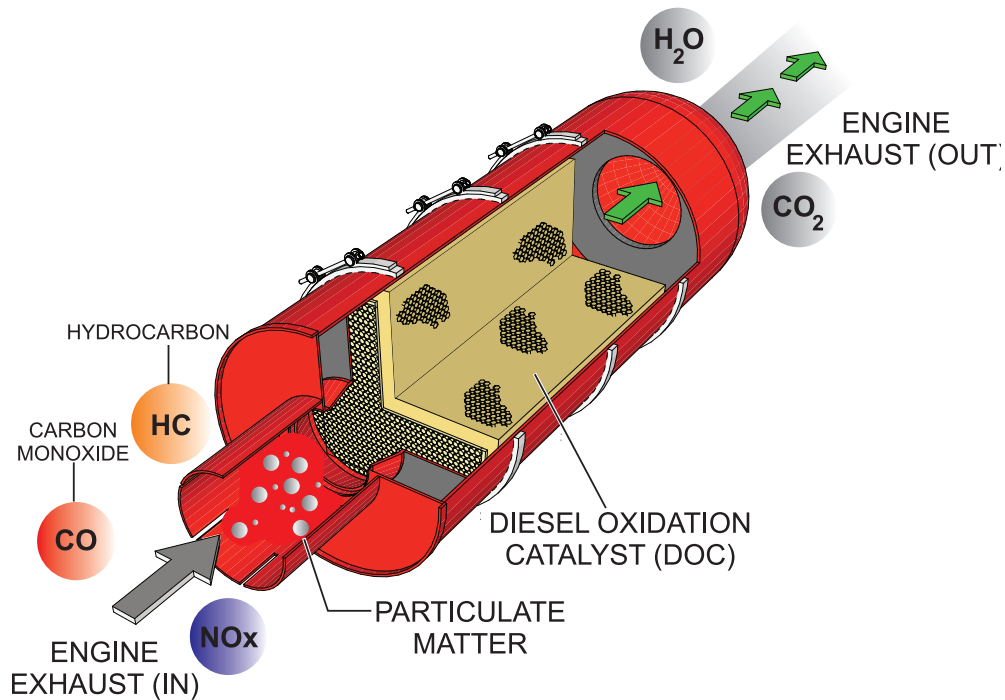

Figure 86. Diesel Oxidation Catalyst (DOC)

SELECTIVE CATALYTIC REDUCTION (SCR)

Diesel engines can be run with a lean burn air-to-fuel ratio, to ensure the full combustion of soot and to prevent the exhaust of unburnt fuel. The excess of air necessarily leads to generation of nitrogen oxides (NO_x), which are harmful pollutants, from the nitrogen in the air. **Selective Catalytic Reduction** is used to reduce the amount of NO_x released into the atmosphere.

Diesel Exhaust Fluid (DEF) from a separate tank is injected into the exhaust pipeline, where the aqueous urea vaporizes and decomposes to form ammonia and carbon dioxide. Within the SCR catalyst, the NO_x are catalytically reduced by the ammonia (NH_3) into water (H_2O) and nitrogen (N_2), which are both harmless; these are then released through the exhaust.

The SCR system creates a certain amount of ammonia (NH_3) that is stored in SCR catalyst. During purging operations the increase in temperature at regular intervals eliminates the stored ammonia.

The process of keeping accurate ammonia storage amounts is by counting urea injection quantities from the Dosing Control Unit (DCU).

The SCR Purge symbol (Figure 87) will be displayed on the ECU controller during operation when either an **automatic** or **forced** system purge operation is in process.

The pre-alarm lamp is only **ON** during SCR forced system purging and **OFF** during automatic system purging.

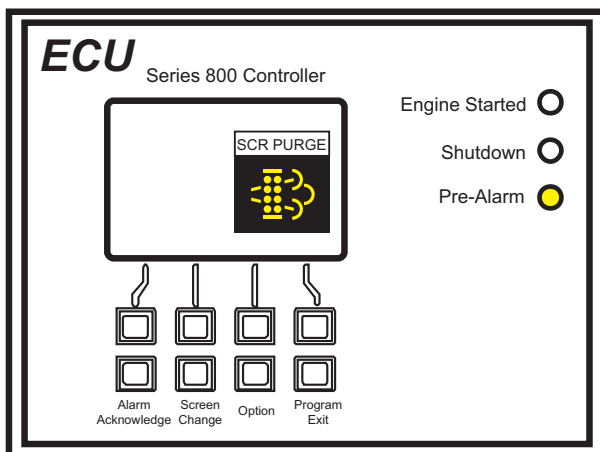

Figure 87. SCR Purge Symbol

NOTICE

During urea SCR system purging, **white smoke** may be temporarily emitted from the exhaust tailpipe. This should not be considered a failure. In addition, the smell of **ammonia** during the purging process should not be considered a failure.

If the purging process is underway while running a light load (0–30%) the unit may produce unusual sounds. This should not be considered a failure or malfunction.

SYSTEM PURGING GUIDELINES

NOTICE

DO NOT perform purging in conditions where it may be unsafe due to high exhaust temperatures.

For safe operation of equipment, safety of the surrounding area, and the prevention of bodily harm, use the guidelines below when system purging is required:

NOTICE

The area above and around the generator during the purging process should be free of any type of debris or flammable or combustible materials, as temperatures during the purging process can reach as high 1,022°F (550°C).

- **DO NOT** operate the unit in an area with poor ventilation.
- If operating the engine indoors, install exhaust/ventilation equipment and ensure that there is sufficient ventilation.
- If you begin to feel sick, stop the unit immediately and ventilate the area.
- Due to the exhaust emission reduction functions of the exhaust system, exhaust emissions from the tailpipe have a different smell from those emitted from engines without urea SCR systems.

If the **diesel exhaust fluid (DEF)** symbol (Figure 88) is displayed during ECU controller operation, it indicates the following:

- DEF tank level is below 10%. Reference Table 17, DEF Level System Action.
- DEF quality is poor. Check DEF tank level and check active **diagnostics trouble codes (DTC)**.

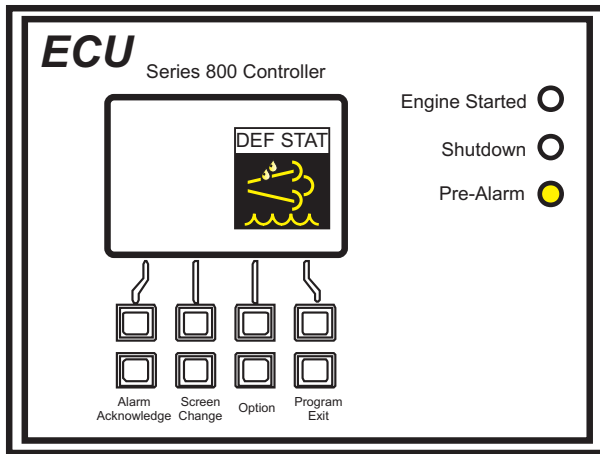

Figure 88. ECU DEF State Pre-Alarm

DIESEL EXHAUST FLUID (DEF)

The amount of fluid in the DEF tank will be shown on the ECU Controller main screen during operation. The symbol shown in Figure 89 will be shown on the ECU monitor indicating the level of fluid in the DEF tank.

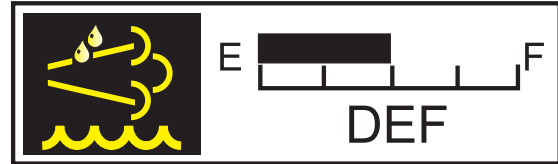

Figure 89. DEF Tank Level Gauge

NOTICE

The unit will enter emergency shutdown when the DEF level has reached 0% and emergency protective measures are necessary. When this condition exists, the unit can only be restarted after ESCAPE MODE is activated and the unit will run for 30 minutes. Reference the “Escape Mode” section in this manual.

Table 17. DEF Level System Action

DEF Level	Over 10%	Below 10%	Below 5%	After 30 Minutes
Controller Message	—	DEF TANK < 10% REFILL DEF	DEF TANK < 5% REFILL DEF	DEF TANK < 0% SD REFILL DEF
SCR System Pop-Up	—	REFILL DEF	REFILL DEF	REFILL DEF
DEF Symbol	—	● ON	● Slow Flashing	● Fast Flashing
Pre-Alarm Lamp	—	● ON	● ON	● ON
Shutdown Lamp	—	—	—	● ON (Engine Shutdown)



INDUCEMENT

When the system senses improper usage such as no supply of DEF, use of poor quality DEF, problems with DEF jets, or disconnection of sensors, a warning will be issued before the situation becomes critical. If the warnings are ignored and the unit enters intermittent operation, the emergency shutdown will activate. The three warning levels are referenced in Table 18:

NOTICE

Replace the DEF filter (located in the urea SCR system supply module) every 3,000 hours of operation. Refer to the **Replacement of DEF Filter** section in the Isuzu engine owner's manual.

Table 18. DEF Inducement

Stage	Controller Message	SCR System Pop-Up	DEF Symbol	Pre-Alarm Lamp	Shutdown Lamp
Stage 1 Warning Level 1	SCR SYSTEM MALFUNCTION	SCR SYS ERR		● ON	—
Stage 2 Warning Level 2	SCR SYSTEM MALFUNCTION	SCR SYS ERR	 Slow Blinking	● ON	—
Stage 3 Shutdown ¹	SCR SYSTEM MALFUNCTION SD	SCR SYS ERR	 Fast Blinking	● ON	● ON

¹When emergency shutdown occurs, inspection and repair should generally be performed promptly. However, if emergency protective measures are necessary, the unit will enter **ESCAPE MODE** and may require as much as 30 minutes to restart.

HOW TO ACTIVATE ESCAPE MODE

If the ECU displays any messages referenced in Table 18, it may be necessary to restart via ESCAPE MODE.

Starting

1. Start the Diagnostic Mode as referenced in the "Troubleshooting Diagnostics" section in this manual.
2. Exit the Status Check Screen by pressing the [EXIT] button (Figure 90).

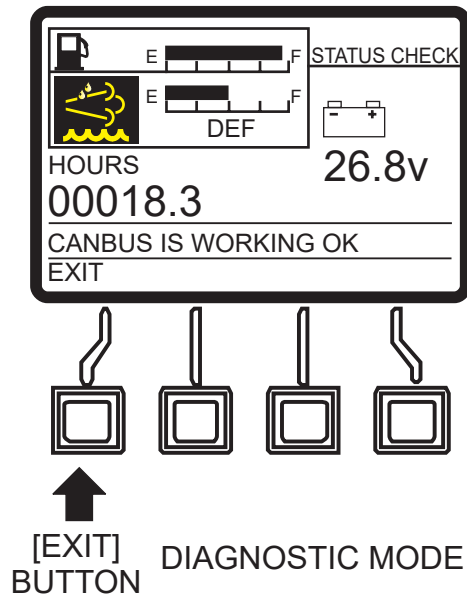

Figure 90. Status Check Screen (Diagnostic Mode)

3. Press the [Program/Exit] button (Figure 91) to enter the Main Menu.

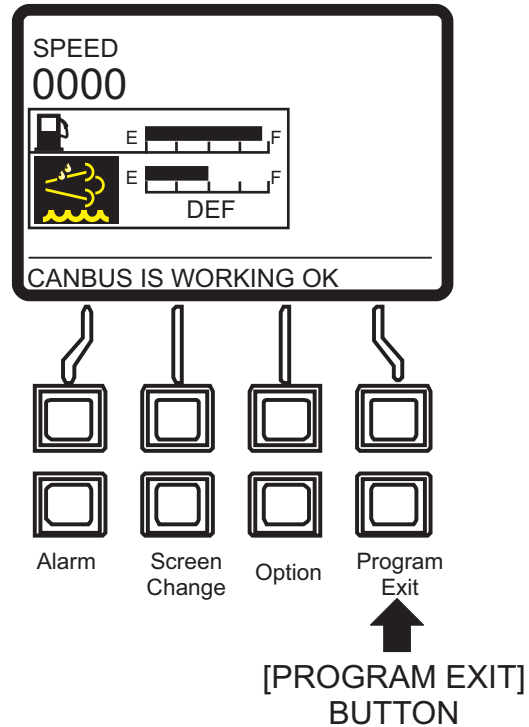

Figure 91. Main Screen

4. Press the [DOWN] button (Figure 92) to scroll to the Escape Mode item.

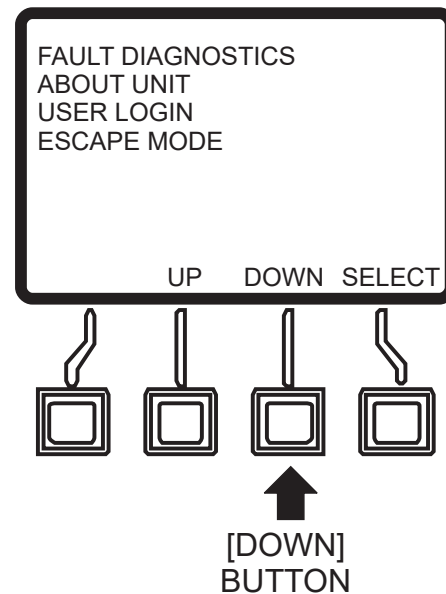

Figure 92. Main Menu (Down Button)

- Press the **[SELECT]** button (Figure 93) to enter the “Escape Mode” menu.

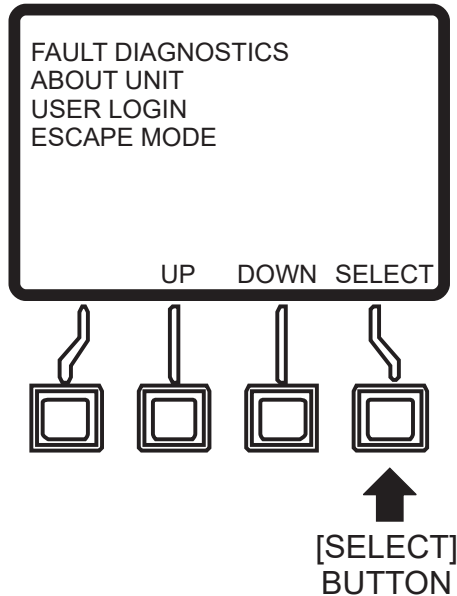

Figure 93. Main Menu (Select Button)

- Press the **[REQUEST]** button (Figure 94) to send “Escape Mode Request” signal to ECM.

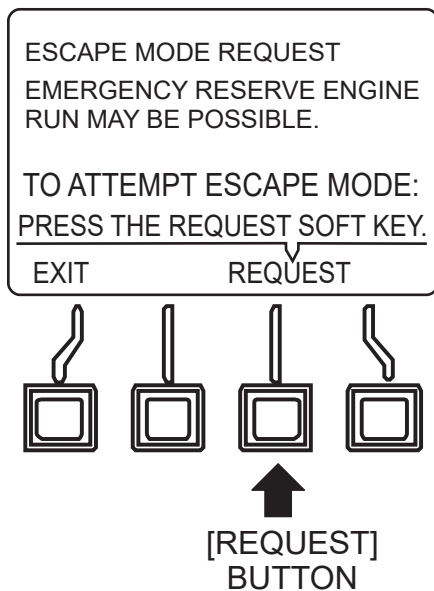

Figure 94. Escape Mode (Request Button)

- Place the Auto Start/Stop switch (Figure 95) in the “Off/Reset” position.

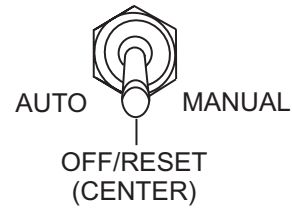

Figure 95. Auto Start/Stop Switch (Off/Reset Position)

- Place the Auto Start/Stop Switch (Figure 96) in the “Manual” position to start the engine.



Figure 96. Auto Start/Stop Switch (Manual Position)

- The **Escape Mode Timer** (Figure 97) will appear on the **main** screen. This timer displays the remaining Escape Mode operation time.

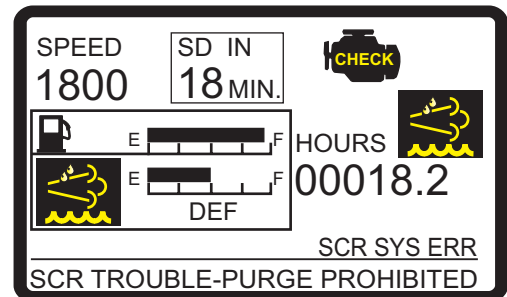

Figure 97. Escape Mode Timer

- If ESCAPE MODE is temporarily suspended, it is not necessary to return to the ESCAPE MODE screen and press the **[REQUEST]** button. ESCAPE MODE operation will be available until around 30 minutes after operation has been ended.
- Once the ESCAPE MODE timer reaches zero minutes, the engine will stop since the ESCAPE MODE time has expired. Please perform maintenance to return the unit to proper operating condition.
- If the unit returns to Warning Level 1 while ESCAPE MODE is running, ESCAPE MODE will be cancelled, the ESCAPE MODE timer display will close, and normal operation will resume.

TROUBLESHOOTING

PROTECTION DEVICES

Automatic Shutdown System

This unit is equipped with engine protection devices that automatically shut down the engine if any of the faults shown in Table 19 occur. The **Shutdown LED** on the ECU controller will turn on just before the shutdown and will stay on after the shutdown. Messages will appear on the ECU display.

After the automatic shutdown, check all diagnostic trouble codes (DTC) displayed on the ECU controller. Refer to the **Troubleshooting (Diagnostics)** section of this manual.

Place the **Auto Start/Stop switch** in the **OFF/RESET** position. In addition, place all circuit breakers in the **OFF** position. Before troubleshooting, allow sufficient time for adequate cooling. Before attempting to restart the generator, perform an overall inspection of the generator and correct the problem that caused the shutdown. If necessary, contact your nearest Multiquip dealer for additional technical support.

Restart the generator as described in the **Generator Startup Procedure (Manual Start)** section of this manual.

NOTICE

Although the unit is equipped with engine protection devices, regularly scheduled preventive maintenance is strongly advised.

Table 19. Automatic Engine Shutdown System

Operating Parameter	ECU Shutdown LED	Operating Condition/Set Point
Low Oil Pressure	● ON	Set point: 14.2 psi (97.9 kPa)
High Water Temperature	● ON	Set point: 212°F (100°C)
Engine Overspeed	● ON	Exceeds approx. +15% of rated speed
Low Coolant Level	● ON	Falls below specified level

TROUBLESHOOTING (DIAGNOSTICS)

The engine controller of this generator diagnoses problems (faults/errors) that arise from the engine control system and the engine itself.

1. With the engine stopped (**OFF**), push and hold the **Hour Check button** (Figure 98) located on the control panel.

HOUR CHECK
BUTTON



Figure 98. Hour Check Button

2. While keeping the **Hour Check button** pressed, place the **Auto Start/Stop switch** (Figure 99) in the **MANUAL** position.



Figure 99. Auto Start/Stop Switch
(Manual Position)

3. The **Hour Check Menu screen** will be displayed on the ECU controller.
4. Release the **Hour Check button** and push the **Program/Exit button** on the ECU controller to return the controller to the main screen.

5. Push the **Program/Exit button** on the ECU controller and select the **Fault Diagnostics** mode. This mode enables the ability to carry out the fault diagnostics as listed below:

■ **DM1 Active Faults** — Displays active fault messages and codes.

■ **DM2 Messages and Codes** — Displays messages and codes which previously occurred that are recorded in the Engine Control Module (ECM).

■ **Last Shutdown** — Displays the messages and codes that caused the most recent shutdown.

6. After performing diagnostic tests, place the **Auto Start/Stop switch** in the **OFF** position.

TROUBLESHOOTING (GENERATOR)

Practically all breakdowns can be prevented by proper handling and maintenance inspections, but in the event of a breakdown, use Table 20 for diagnosis of the generator. If the problem cannot be remedied, consult our company's business office or service plant.

Table 20. Generator Troubleshooting		
Symptom	Possible Problem	Solution
No Voltage Output	Defective AC voltmeter?	Check output voltage and replace if necessary.
	Loose wiring connection?	Check wiring and repair.
	Defective AVR?	Replace if necessary.
	Defective rotating rectifier?	Check and replace.
Low Voltage Output	Low engine speed?	Check and adjust.
	Loose wiring connection?	Check wiring and repair.
	Defective AVR?	Replace if necessary.
High Voltage Output	Loose wiring connection?	Check wiring and repair.
	Defective AVR?	Replace if necessary.
Circuit Breaker Tripped	Short circuit in load?	Check load and repair.
	Over current?	Confirm load requirement and reduce.
	Defective circuit breaker?	Check and replace.
	Overcurrent relay actuated?	Confirm load requirement and reset.

TROUBLESHOOTING (ENGINE)

Troubleshooting (Engine)		
Symptom	Possible Problem	Solution
Engine will not start or start is delayed, although engine can be turned over.	No fuel reaching injection pump?	Add fuel. Check entire fuel system.
	Defective fuel pump?	Replace fuel pump.
	Fuel filter clogged?	Replace fuel filter and clean tank.
	Faulty fuel supply line?	Replace or repair fuel line.
	Compression too low?	Check piston, cylinder and valves. Adjust or repair per engine repair manual.
	Fuel pump not working correctly?	Repair or replace fuel pump.
	Oil pressure too low?	Check engine oil pressure.
	Low starting temperature limit exceeded?	Comply with cold starting instructions and proper oil viscosity.
	Defective battery?	Charge or replace battery.
	Air or water mixed in fuel system?	Check carefully for loosened fuel line coupling, loose cap nut, etc.
At low temperatures engine will not start.	Engine oil too thick?	Refill engine crankcase with correct type of oil for winter environment.
	Defective battery?	Replace battery.
Engine fires but stops as soon as starter is switched off.	Fuel filter blocked?	Replace fuel filter.
	Fuel supply blocked?	Check the entire fuel system.
	Defective fuel pump?	Replace fuel pump.
Engine stops by itself during normal operation.	Fuel tank empty?	Add fuel.
	Fuel filter blocked?	Replace fuel filter.
	Defective fuel pump?	Replace fuel pump.
	Mechanical oil pressure shutdown sensor stops the engine due to low oil?	Add oil. Replace low oil shutdown sensor if necessary.
Low engine power, output and speed.	Fuel tank empty?	Add fuel.
	Fuel filter clogged?	Replace fuel filter.
	Fuel tank venting is inadequate?	Ensure tank is adequately vented.
	Leaks at pipe unions?	Check threaded pipe unions. Tape and tighten unions as required.
	Speed control lever does not remain in selected position?	See engine manual for corrective action.
	Engine oil level too full?	Correct engine oil level.
	Injection pump wear?	Use No. 2-D diesel fuel only. Check the fuel injection pump element and delivery valve assembly and replace as necessary.

TROUBLESHOOTING (ENGINE)

Troubleshooting (Engine) - continued		
Symptom	Possible Problem	Solution
Low engine power output and low speed, black exhaust smoke.	Air filter blocked?	Clean or replace air filter.
	Incorrect valve clearances?	Adjust valves per engine specification.
	Malfunction at injector?	See engine manual.
Engine overheats.	Too much oil in engine crankcase?	Drain off engine oil down to upper mark on dipstick.
	Entire cooling air system contaminated or blocked?	Clean cooling air system and cooling fin areas.
	Fan belt broken or elongated?	Change belt or adjust belt tension.
	Coolant insufficient?	Replenish coolant.
	Radiator net or radiator fin clogged with dust?	Clean net or fin carefully.
	Fan, radiator, or radiator cap defective?	Replace defective part.
	Thermostat defective?	Check thermostat and replace if necessary.
Head gasket defective or water leakage?	Replace parts.	

GENERATOR WIRING DIAGRAM (M3814000623)

SYMBOL	DESIGNATION
A.T.	MAIN GENERATOR ARMATURE WINDING
F.G.	MAIN GENERATOR FIELD WINDING
EX.A.F.	EXCITER ARMATURE WINDING
EX.F.G.	EXCITER FIELD WINDING
Re	RECTIFIER
AVR	AUTOMATIC VOLTAGE REGULATOR
VR	VOLTAGE REGULATOR (RHROSTAT)
CT 1, 2, 3	CURRENT TRANSFORMER
CT 4, 5	CURRENT TRANSFORMER
AS	CHANGE-OVER SWITCH, AMMETER
A	AC. AMMETER
VS	CHANGE-OVER SWITCH, VOLTMETER
V	AC. VOLTMETER
F	FREQUENCY METER
CB1	CIRCUIT BREAKER 3P 300A
CB2, 3, 4	CIRCUIT BREAKER 2P 50A
CB5, 6	CIRCUIT BREAKER 1P 20A
CON1, 2, 3	RECEPTACLE 250V 50A
CON4, 5	RECEPTACLE 175V 20A x 2 (G. F. C. I.)
OC	OVER CURRENT RELAY
SW	SELECTOR SWITCH
RY1, 2	RELAY UNIT

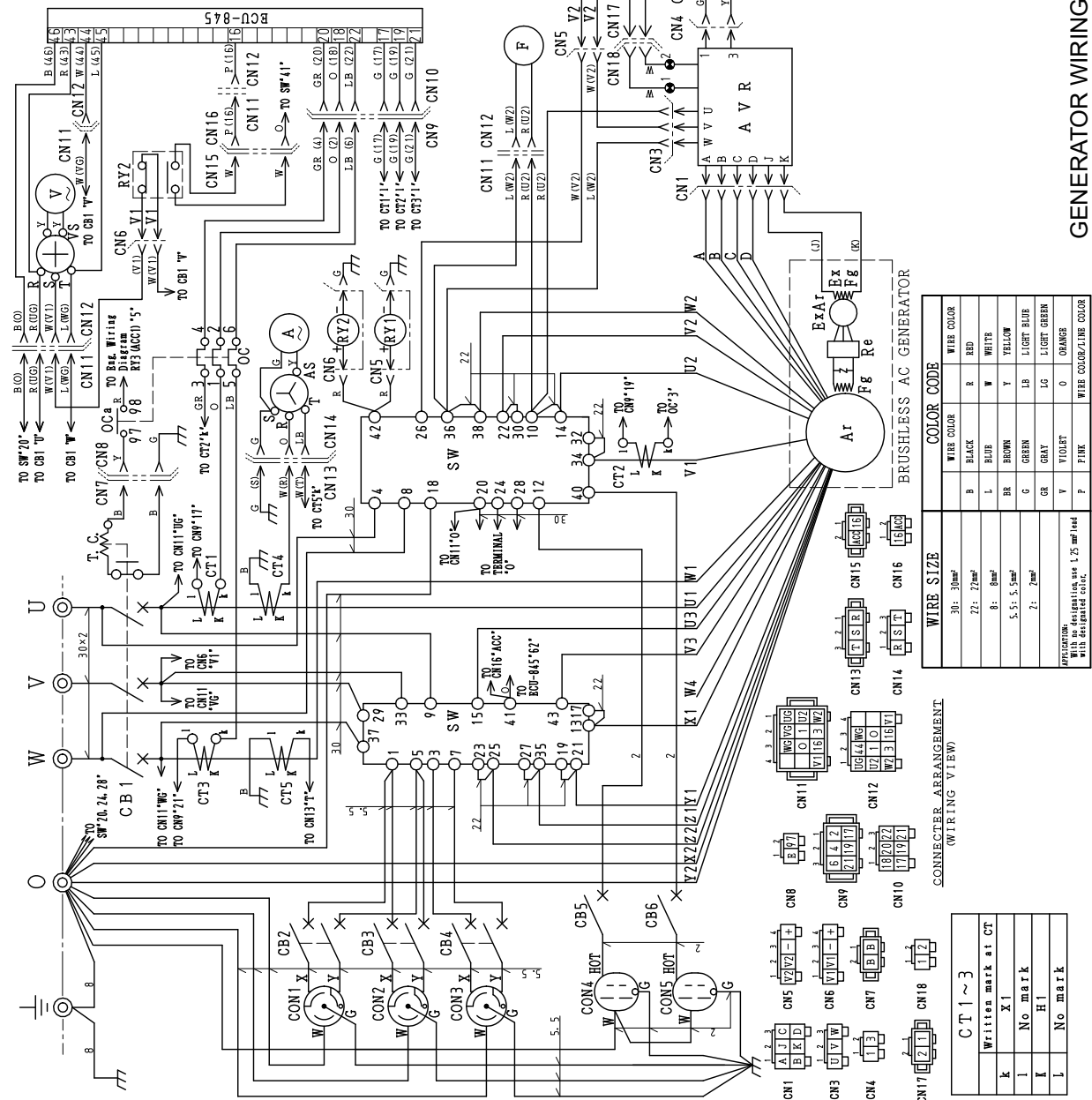

GENERATOR WIRING DIAGRAM NO. M3814000623

WIRE SIZE	COLOR CODE
30: 3mm ²	WIRE COLOR
22: 2mm ²	B BLACK
8: 8mm ²	L BLUE
5.5: 5.5mm ²	BR BROWN
2: 2mm ²	G GREEN
	GR GRAY
	Y YELLOW
	LB LIGHT BLUE
	LG LIGHT GREEN
	V VIOLET
	OR ORANGE
	P PINK
	W WHITE
	R RED

CONNECTOR ARRANGEMENT	WIRING VIEW
CN1	
CN2	
CN3	
CN4	
CN5	
CN6	
CN7	
CN8	
CN9	
CN10	
CN11	
CN12	
CN13	
CN14	
CN15	
CN16	
CN17	
CN18	

CT 1 ~ 3
Written mark at CT
X1
No. mark
H1
No. mark

ENGINE WIRING DIAGRAM (M3814100843)

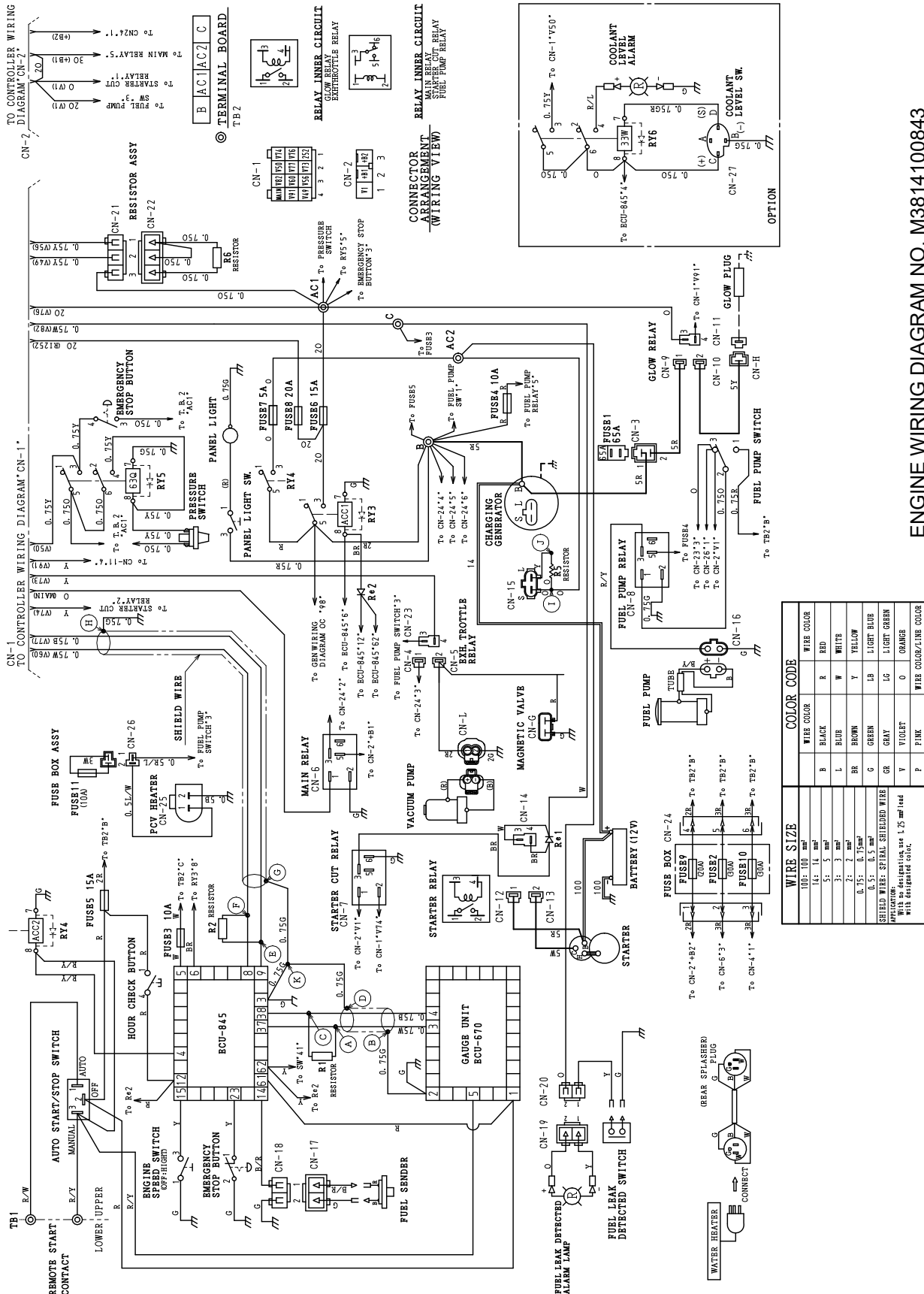

ENGINE WIRING DIAGRAM NO. M3814100843

CONTROLLER WIRING DIAGRAM (A) (M3814100903)

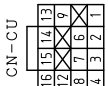
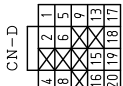
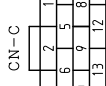
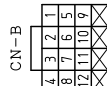
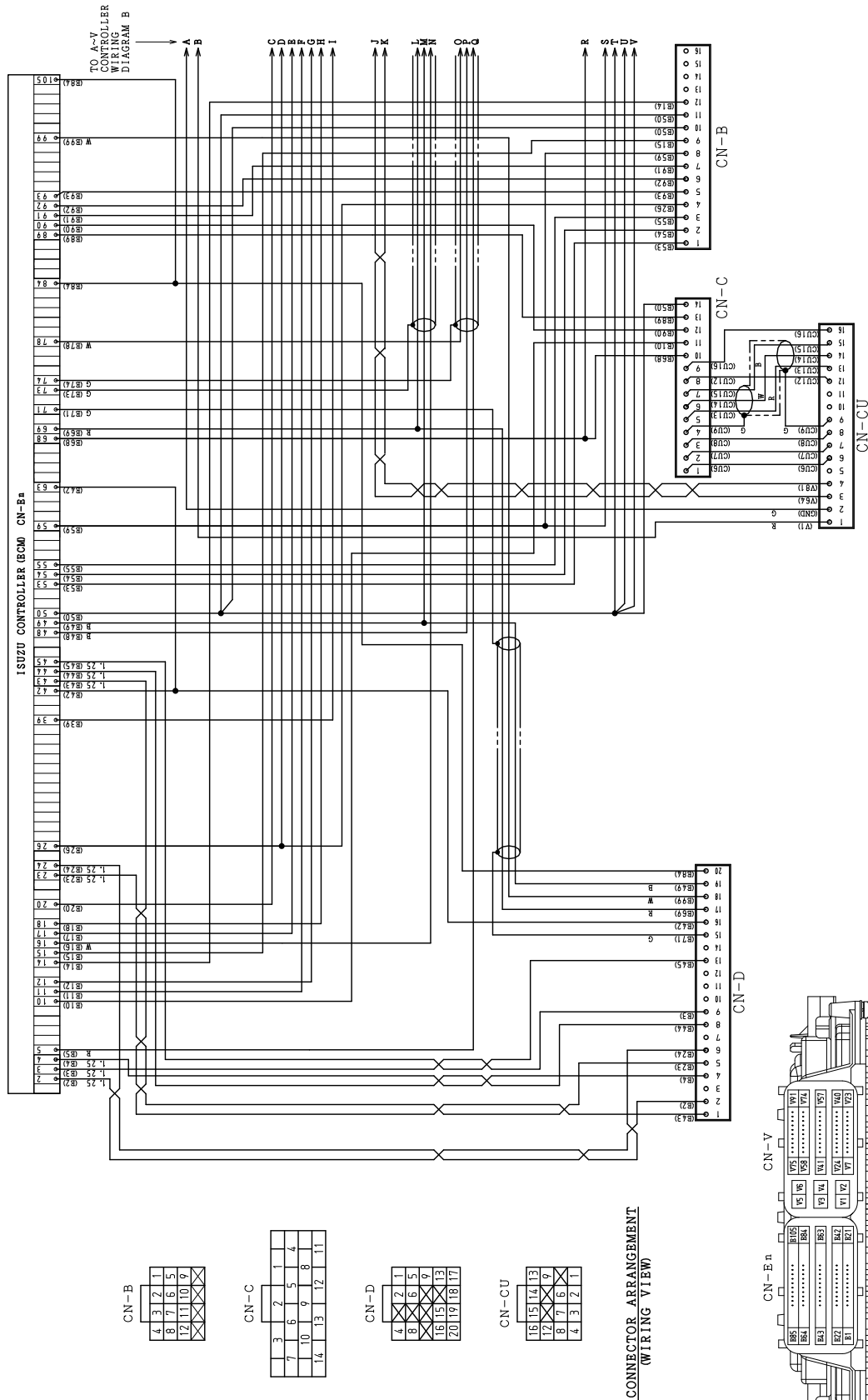

CONNECTOR ARRANGEMENT (WIRING VIEW)

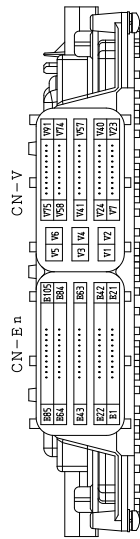

ECM CONNECTOR ARRANGEMENT (WIRING VIEW)

WIRE SIZE	COLOR CODE
2 : 2mm ²	WIRE COLOR
1.25 : 1.25mm ²	B BRACK R RED
0.5 : 0.5mm ²	L BLUE W WHITE
	BR BROWN Y YELLOW
	G GREEN LB LIGHT BLUE
NO MARK : 0.75mm ²	GR GRAY LG LIGHT GREEN
NO MARK : YELLOW	V VIOLET O ORANGE
	P PINK

CONTROLLER WIRING DIAGRAM (A) NO. M3814100903

CONTROLLER WIRING DIAGRAM (B) (M3814101013)

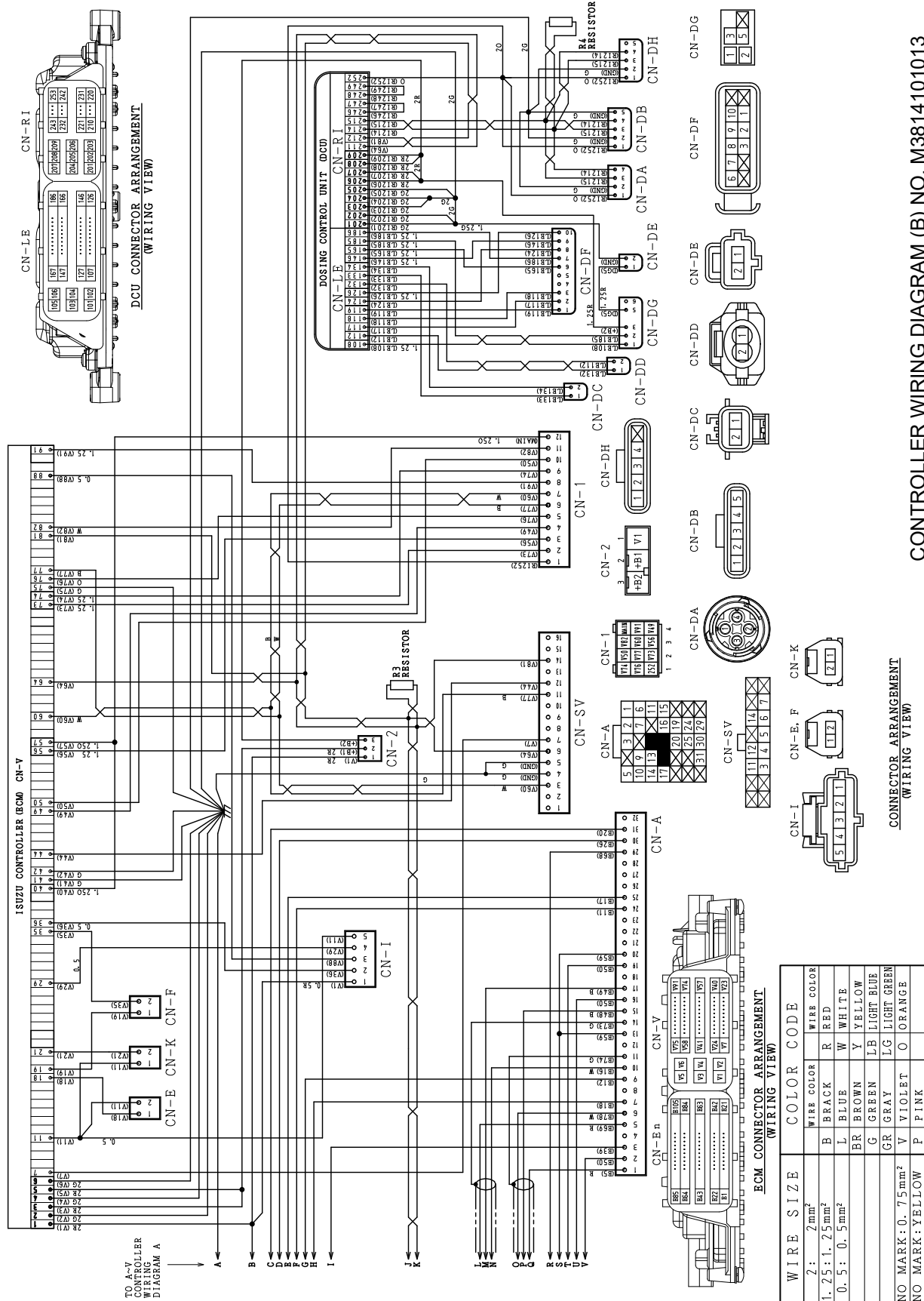

BATTERY CHARGER WIRING DIAGRAM (OPTION)

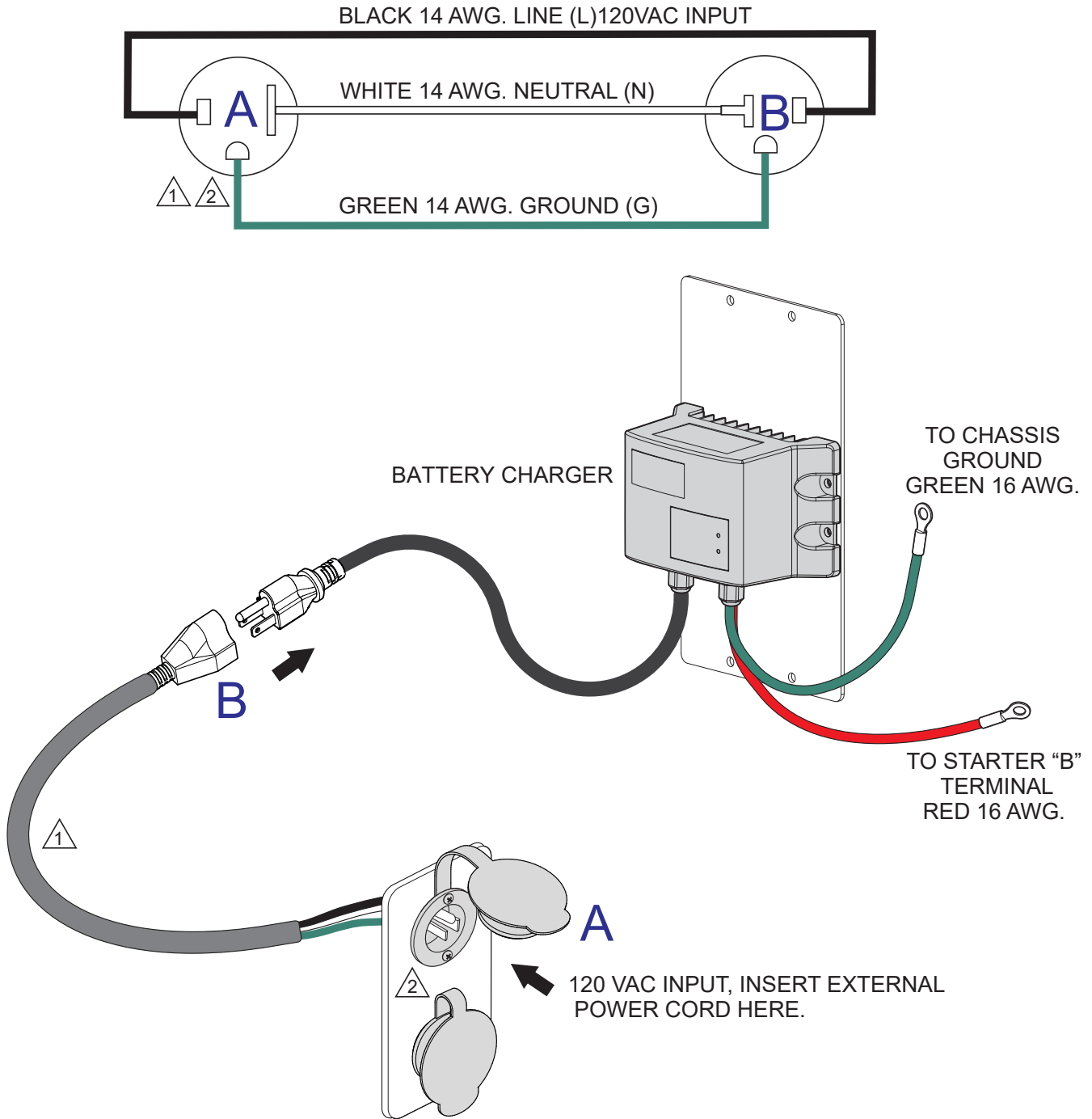

NOTES:

① INLET RECEPTACLE & CORD, NEMA 5-15P, 15 AMP, 125V, P/N EE62076

② RECEPTACLE IS MOUNTED ON OUTPUT TERMINAL PANEL ASSY.

OPERATION MANUAL

HERE'S HOW TO GET HELP

PLEASE HAVE THE MODEL AND SERIAL
NUMBER ON HAND WHEN CALLING

UNITED STATES

Multiquip Inc.

(310) 537- 3700
6141 Katella Avenue Suite 200
Cypress, CA 90630
E-MAIL: mq@multiquip.com
WEBSITE: www.multiquip.com

CANADA

Multiquip

(450) 625-2244
4110 Industriel Boul.
Laval, Quebec, Canada H7L 6V3
E-MAIL: infocanada@multiquip.com

UNITED KINGDOM

Multiquip (UK) Limited Head Office

0161 339 2223
Unit 2, Northpoint Industrial Estate, Globe Lane,
Dukinfield, Cheshire SK16 4UJ
E-MAIL: sales@multiquip.co.uk

© COPYRIGHT 2025, MULTIQUIP INC.

Multiquip Inc., the MQ logo and the MQ Power logo are registered trademarks of Multiquip Inc. and may not be used, reproduced, or altered without written permission. All other trademarks are the property of their respective owners and used with permission.

This manual MUST accompany the equipment at all times. This manual is considered a permanent part of the equipment and should remain with the unit if resold.

The information and specifications included in this publication were in effect at the time of approval for printing. Illustrations, descriptions, references and technical data contained in this manual are for guidance only and may not be considered as binding. Multiquip Inc. reserves the right to discontinue or change specifications, design or the information published in this publication at any time without notice and without incurring any obligations.

Manufactured for
MQ Power Inc.
by
DENYO MANUFACTURING CORP.

