

OPERATION MANUAL



WHISPERWATT™ SERIES
MODEL DCA150SSJU4F2
MODEL DCA150SSJU4F3
60Hz GENERATORS
(JOHN DEERE 6068HFG05 DIESEL ENGINE)

INSTRUCTION MANUAL NO. M3844300704/DCA150SSJU4F2

INSTRUCTION MANUAL NO. M3844301204/DCA150SSJU4F3

Revision #2 (03/11/25)

To find the latest revision of this publication or
associated parts manual, visit our website at:

www.mqpower.com



THIS MANUAL MUST ACCOMPANY THE EQUIPMENT AT ALL TIMES.

PROPOSITION 65 WARNING



TABLE OF CONTENTS

DCA150SSJU4F2 DCA150SSJU4F3 60 Hz Generators

NOTICE

Specifications are subject to change without notice.

Proposition 65 Warning 2
Table of Contents..... 3
Safety Decals 4
Safety Information 5–10
Specifications 12
Dimensions..... 13
Installation 14–15
General Information..... 16–17
General Paralleling Information (Option) 18–20
Major Components 21
Engine Control Unit (ECU-845) 22
Gauge Unit Assembly (ECU-670)..... 23
Engine/Generator Control Panel 24
Basler Digital Genset Controller (Option) 26–27
Paralleling Panel (Option)..... 28–29
Output Terminal Panel Familiarization..... 30–32
Load Application 33
PowerBalance® 34
Generator Outputs..... 35
Gauge Reading 36
Output Terminal Panel Connections 37–38
Inspection/Setup..... 39–44
Generator Start-Up Procedure (Manual) 45–47
Generator Start-Up Procedure (Auto)..... 48
Generator Shutdown Procedure..... 49
Maintenance 50–68
Troubleshooting (Diagnostics)..... 69–70
Troubleshooting (Generator) 71
Troubleshooting (Engine) 72–73
Generator Wiring Diagrams..... 74–75
Engine Wiring Diagrams..... 76–78
Battery Charger Wiring Diagram (Option) 79

SAFETY DECALS

Safety decals are attached to the generator as shown in Figure 1. Keep these safety decals clean at all times. When the safety decals become worn or damaged, contact your nearest dealer or the Multiquip Parts Department.

NOTICE
For safety decal part numbers, refer to the associated parts manual.

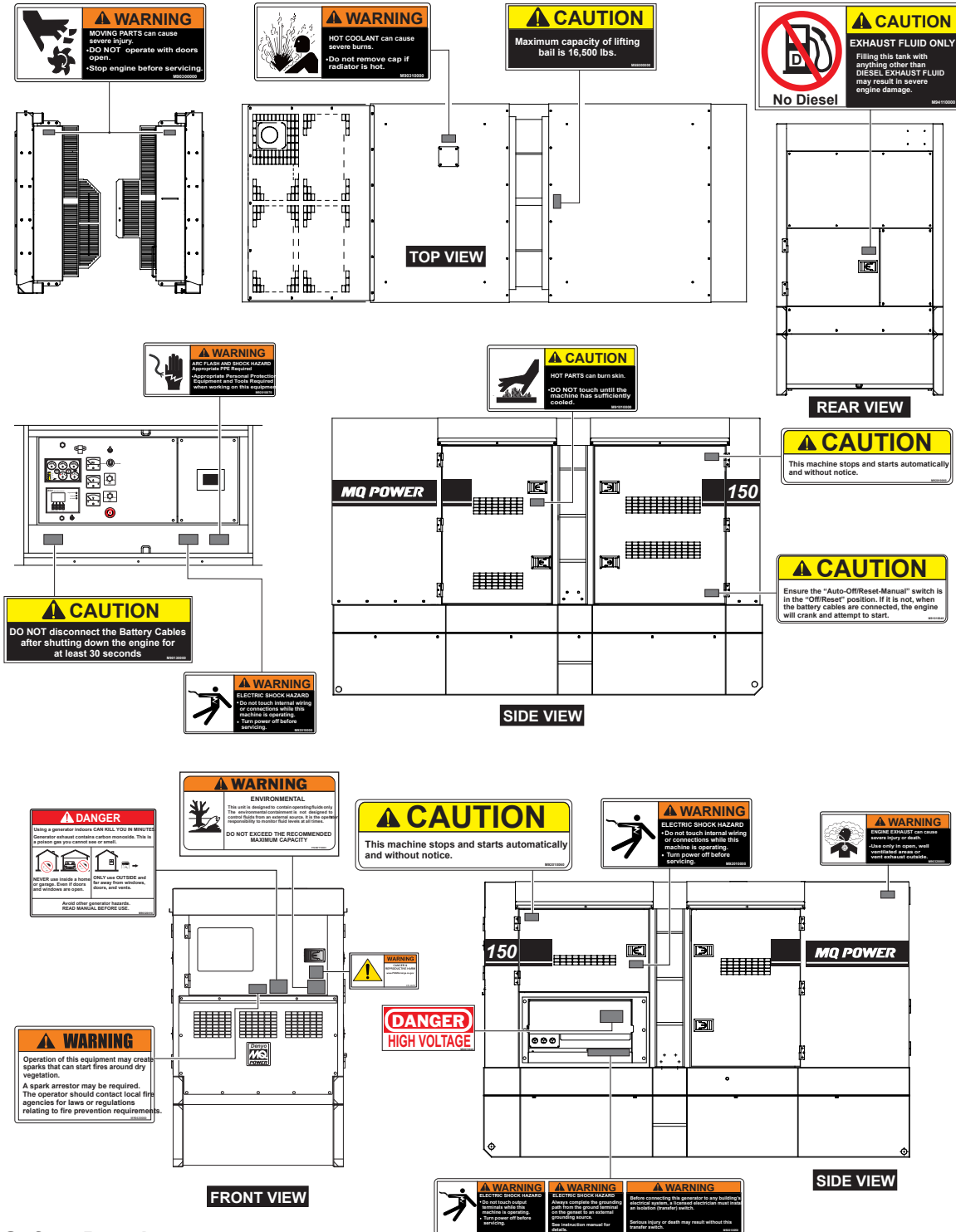

Figure 1. Safety Decals

SAFETY INFORMATION

Do not operate or service the generator before reading the entire manual. Safety precautions should be followed at all times when operating this generator. Failure to read and understand the safety messages and operating instructions could result in injury to yourself and others.







SAFETY MESSAGES

The four safety messages shown below will inform you about potential hazards that could injure you or others. The safety messages specifically address the level of exposure to the operator and are preceded by one of four words: **DANGER**, **WARNING**, **CAUTION** or **NOTICE**.

SAFETY SYMBOLS

 DANGER
Indicates a hazardous situation which, if not avoided, WILL result in DEATH or SERIOUS INJURY .
 WARNING
Indicates a hazardous situation which, if not avoided, COULD result in DEATH or SERIOUS INJURY .
 CAUTION
Indicates a hazardous situation which, if not avoided, COULD result in MINOR or MODERATE INJURY .
NOTICE
Addresses practices not related to personal injury.

Potential hazards associated with the operation of this generator will be referenced with hazard symbols which may appear throughout this manual in conjunction with safety messages.

Symbol	Safety Hazard
	Lethal exhaust gas hazards
	Explosive fuel hazards
	Burn hazards
	Overspeed hazards
	Rotating parts hazards
	Pressurized fluid hazards
	Electric shock hazards

SAFETY INFORMATION

GENERAL SAFETY

CAUTION

- **NEVER** operate this generator without proper protective clothing, shatterproof glasses, respiratory protection, hearing protection, steel-toed boots and other protective devices required by the job or city and state regulations.



- **NEVER** operate this generator when not feeling well due to fatigue or illness, or when on medication.
- **NEVER** operate this generator under the influence of drugs or alcohol.



- **ALWAYS** check the generator for loosened threads or bolts before starting.
- **NEVER** use the generator for any purpose other than its intended purposes or applications.

NOTICE

- This generator should only be operated by trained and qualified personnel 18 years of age and older.
- Whenever necessary, replace nameplate, operation and safety decals when they become difficult to read.
- Manufacturer does not assume responsibility for any accident due to equipment modifications. Unauthorized modification of the generator will void all warranties.
- **NEVER** use accessories or attachments that are not recommended by MQ Power for this generator. Damage to the generator and/or injury to the user may result.
- **ALWAYS** know the location of the nearest **fire extinguisher**.
- **ALWAYS** know the location of the nearest **first aid kit**.



- **ALWAYS** know the location of the nearest phone or **keep a phone on the job site**. Also, know the phone numbers of the nearest **ambulance, doctor, and fire department**. This information will be invaluable in the case of an emergency.



GENERATOR SAFETY

DANGER

- **NEVER** operate the generator in an explosive atmosphere or near combustible materials. An explosion or fire could result causing **severe bodily harm or even death**.



WARNING

- **NEVER** disconnect any **emergency or safety devices**. These devices are intended for operator safety. Disconnection of these devices can cause **severe injury, bodily harm or even death**. Disconnection of any of these devices will void all warranties.

CAUTION

- **NEVER** lubricate components or attempt service on a **running generator**.

NOTICE

- **ALWAYS** ensure the generator is on level ground before use.
- **ALWAYS** keep the generator in proper running condition.
- Fix damage to the generator and replace any broken parts immediately.
- **ALWAYS** store the generator properly when it is not being used. The generator should be stored in a clean, dry location out of the reach of children and unauthorized personnel.

SAFETY INFORMATION

ENGINE SAFETY

DANGER

■ The engine fuel exhaust gases contain poisonous carbon monoxide. This gas is colorless and odorless, and can cause **death** if inhaled.

■ The engine of this generator requires an adequate, free flow of cooling air. **NEVER** operate this equipment in any enclosed or narrow area where free flow of the air is restricted. If the air flow is restricted it will cause injury to people and property and serious damage to the equipment or engine.



■ When operating the generator outdoors, **DO NOT** place the generator near doors, windows or vents that could allow carbon monoxide to enter and build up in occupied spaces.

WARNING

■ **NEVER** place hands or fingers inside the engine compartment when the engine is running.

■ **NEVER** operate the engine with heat shields or guards removed.

■ Keep fingers, hands, hair and clothing away from all moving parts to prevent injury.



■ **NEVER** operate the generator with the doors open. Stop the engine before servicing.

■ **DO NOT** remove the radiator cap while the engine is hot. High pressure boiling water will gush out of the radiator and severely scald any persons in the general area of the generator.



■ **DO NOT** remove the coolant drain plug while the engine is hot. Hot coolant will gush out of the coolant tank and severely scald any persons in the general area of the generator.

■ **DO NOT** drain the engine oil while the engine is hot. Hot oil will gush out and severely scald any persons near the generator.

■ Operation of the generator may create sparks that can start fires around dry vegetation. A spark arrestor may be required. The operator should contact local fire agencies for laws or regulations relating to fire prevention requirements.

CAUTION

■ **NEVER** touch the hot exhaust manifold, muffler or cylinder. Allow these parts to cool before servicing the generator.



NOTICE

■ **NEVER** run the engine without an air filter or with a dirty air filter. Severe engine damage may occur. Service the air filter frequently to prevent engine malfunction.

■ **NEVER** tamper with the factory settings of the engine or engine governor. Damage to the engine or generator can result if operating in speed ranges above the maximum allowable.



■ Wet stacking is a common problem with diesel engines which are operated for extended periods with light or no load applied. When a diesel engine operates without sufficient load (less than 30-35% of the rated output), it will not operate at its optimum temperature. This will allow unburned fuel to accumulate in the exhaust system, which can foul the fuel injectors, engine valves and exhaust system, including turbochargers, and reduce the operating performance.

In order for a diesel engine to operate at peak efficiency, it must be able to provide fuel and air in the proper ratio and at a high enough engine temperature for the engine to completely burn all of the fuel.

Wet stacking does not usually cause any permanent damage and can be alleviated if additional load is applied to relieve the condition. It can reduce the system performance and increase maintenance. Applying an increasing load over a period of time until the excess fuel is burned off and the system capacity is reached usually can repair the condition. This can take several hours to burn off the accumulated unburned fuel.

SAFETY INFORMATION

FUEL SAFETY

DANGER

- **NEVER** start the engine near spilled fuel or combustible fluids. Diesel fuel is extremely flammable and its vapors can cause an explosion if ignited.
- **ALWAYS** refuel in a well-ventilated area, away from sparks and open flames.
- **ALWAYS** use extreme caution when working with **flammable** liquids.
- **NEVER** fill the fuel tank while the engine is **running** or **hot**.
- **NEVER** overfill the fuel tank. Spilled fuel can ignite if it comes into contact with hot engine parts or sparks from the ignition system.
- Store fuel in appropriate containers, in well-ventilated areas and away from sparks and flames.
- **NEVER** use fuel as a cleaning agent.
- **NEVER** smoke around or near the equipment. Fire or explosion could result from fuel vapors or if fuel is spilled on a hot engine.



TOWING SAFETY

CAUTION

- Check with your local county or state safety towing regulations, in addition to meeting **Department of Transportation (DOT) Safety Towing Regulations**, before towing your generator.
- Refer to the MQ Power trailer manual for additional safety information.
- In order to reduce the possibility of an accident while transporting the generator on public roads, **ALWAYS** make sure that the trailer that supports the generator and the towing vehicle are both mechanically sound and in good operating condition.
- **ALWAYS** shut down the engine before transporting.



- Make sure the hitch and coupling of the towing vehicle are rated equal to or greater than the trailer **gross vehicle weight rating**.
- **ALWAYS** inspect the hitch and coupling for wear. **NEVER** tow a trailer with defective hitches, couplings, chains, etc.
- Check the tire air pressure on both the towing vehicle and the trailer. **Inflate trailer tires as indicated on side wall of tire**. Also check the tire tread wear on both vehicles.
- **ALWAYS** make sure the trailer is equipped with **safety chains**.
- **ALWAYS** properly attach the trailer's safety chains to the towing vehicle.
- **ALWAYS** make sure the vehicle and trailer directional, backup, brake, and trailer lights are connected and working properly.
- DOT requirements include the following:
 - Connect and test electric brake operation.
 - Secure portable power cables in cable tray with tie wraps.
- The maximum speed for highway towing is **55 MPH** unless posted otherwise. Recommended off-road towing is not to exceed **15 MPH** or less depending on the type of terrain.
- Avoid sudden stops and starts. These can cause skidding or jackknifing. Smooth, gradual starts and stops will improve towing.
- Avoid sharp turns to prevent rolling.
- The trailer should be adjusted to a level position at all times when towing.
- Raise and lock the trailer wheel stand in the upright position when towing.
- Place **chock blocks** underneath the wheels to prevent **rolling** while parked.
- Place **support blocks** underneath the trailer's bumper to prevent **tipping** while parked.
- Use the trailer's swivel jack to adjust the trailer height to a level position while parked.

SAFETY INFORMATION

ELECTRICAL SAFETY

DANGER

- **NEVER** touch the output terminals during operation. Contact with the output terminals during operation can cause **electrocution, electrical shock, or burn**.



- The electrical voltage required to operate the generator can cause **severe injury or even death** through physical contact with live circuits. Turn the generator and all circuit breakers **OFF** before performing maintenance on the generator or making contact with the output terminals.

- **NEVER** insert any objects into the output receptacles during operation. This is extremely dangerous. The possibility exists of **electrical shock, electrocution or death**.



- Backfeed to a utility system can cause **electrocution** and/or property damage. **NEVER** connect the generator to a building's electrical system without a transfer switch or other approved device. All installations should be performed by a **licensed electrician** in accordance with all applicable laws and electrical codes. Failure to do so could result in electrical shock or burn, causing **serious injury or even death**.



Power Cord/Cable Safety

DANGER

- **NEVER** let power cords or cables **lay in water**.
- **NEVER** **stand in water** while AC power from the generator is being transferred to a load.
- **NEVER** use **damaged** or **worn** cables or cords when connecting equipment to the generator. Inspect the insulation for cuts.
- **NEVER** grab or touch a live power cord or cable with wet hands. The possibility exists of **electrical shock, electrocution or death**.

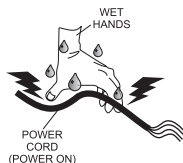

- Make sure power cables are securely connected to the generator's output receptacles. Incorrect connections may cause electrical shock and damage to the generator.

NOTICE

- **ALWAYS** make certain that the proper power or extension cord has been selected for the job. See the Cable Selection Chart in this manual.

Grounding Safety

DANGER

- **ALWAYS** make sure that electrical circuits are properly grounded to a suitable earth ground (ground rod) per the National Electrical Code (NEC) and local codes before operating the generator. **Severe injury or death by electrocution** can result from operating an ungrounded generator.
- **NEVER** use gas piping as an electrical ground.

BATTERY SAFETY

DANGER

- **DO NOT** drop the battery. There is a possibility that the battery will explode.
- **NEVER** expose the battery to open flames, sparks, cigarettes, etc. The battery contains combustible gases and liquids. If these gases and liquids come into contact with a flame or spark, an explosion could occur.



WARNING

- **ALWAYS** wear safety glasses when handling the battery to avoid eye irritation. The battery contains acids that can cause injury to the eyes and skin.
- Use well-insulated gloves when picking up the battery.
- **ALWAYS** keep the battery charged. If the battery is not charged, combustible gas will build up.
- **ALWAYS** recharge the battery in a well-ventilated environment to avoid the risk of a dangerous concentration of combustible gases.
- If the battery liquid (dilute sulfuric acid) comes into contact with **clothing or skin**, rinse skin or clothing immediately with plenty of water.



SAFETY INFORMATION

- If the battery liquid (dilute sulfuric acid) comes into contact with **eyes**, rinse eyes immediately with plenty of water and contact the nearest doctor or hospital to seek medical attention.

CAUTION

- **ALWAYS** disconnect the **NEGATIVE** battery terminal before performing service on the generator.
- **ALWAYS** keep battery cables in good working condition. Repair or replace all worn cables.

ENVIRONMENTAL SAFETY/DECOMMISSIONING

NOTICE

Decommissioning is a controlled process used to safely retire a piece of equipment that is no longer serviceable. If the equipment poses an unacceptable and unreparable safety risk due to wear or damage or is no longer cost effective to maintain (beyond life-cycle reliability) and is to be decommissioned (demolition and dismantlement), be sure to follow the rules below:

- **NEVER** pour waste or oil directly onto the ground, down a drain, or into any water source.
- Contact your country's Department of Public Works or recycling agency in your area and arrange for proper disposal of any electrical components, waste or oil associated with this equipment.
- When the life cycle of this equipment is over, remove the battery and bring it to an appropriate facility for lead reclamation. Use safety precautions when handling batteries that contain sulfuric acid.
- When the life cycle of this equipment is over, it is recommended that the frame and all other metal parts be sent to a recycling center.



Metal recycling involves the collection of metal from discarded products and its transformation into raw materials to use in manufacturing a new product.

Recyclers and manufacturers alike promote the process of recycling metal. Using a metal recycling center promotes energy cost savings.

EMISSIONS INFORMATION

NOTICE

The diesel engine used in this equipment has been designed to reduce harmful levels of carbon monoxide (CO), hydrocarbons (HC), and nitrogen oxides (NOx) contained in diesel exhaust emissions.

This engine has been certified to meet US EPA evaporative emissions requirements in the installed configuration.

Attempting to modify or make adjustments to the engine emission system by unauthorized personnel without proper training could damage the equipment or create an unsafe condition.

Additionally, modifying the fuel system may adversely affect evaporative emissions, resulting in fines or other penalties.

Emission Control Label

The emission control label is an integral part of the emission system and is strictly controlled by regulations.

The label must remain with the engine for its entire life.

If a replacement emission label is needed, please contact your authorized engine distributor.

SPECIFICATIONS

Table 1. Generator Specifications

Model	DCA150SSJU4F2	DCA150SSJU4F3
Type	Revolving field, self-ventilated, open protected type synchronous generator	
Armature Connection	Star with Neutral	Zigzag
Phase	3Ø	Single
Standby Output	132 kW (165 kVA)	95.7 kW
Prime Output	120 kW (150 kVA)	87 kW
3Ø Voltage (L-L/L-N) Voltage Selector Switch at 3Ø 240/139V	208Y/120, 220Y/127, 240Y/139	N/A
3Ø Voltage (L-L/L-N) Voltage Selector Switch at 3Ø 480/277V	416Y/240, 440Y/254, 480Y/277	N/A
1Ø Voltage (L-L/L-N) Voltage Selector Switch at 1Ø 240/120V	N/A	240/120
Power Factor	0.8	1.0
Frequency	60 Hz	
Speed	1,800 rpm	
Aux. AC Power	Single phase, 60 Hz	
Pitch	2/3	
Subtransient	0.089	
Transient	0.129	
Synchronous	1.182	
Zero Sequence Reactance	0.005	
Overload Protection	OCR/Main circuit breaker	
Aux. Voltage/Output	4.8 kW (2.4 kW × 2)	
Dry Weight	8,201 lb. (3,720 kg)	
Wet Weight	10,869 lb. (4,930 kg)	

Table 2. Engine Specifications

Model	John Deere 6068HFG05 Final Tier 4	
Type	4-cycle, water-cooled, direct injection, turbocharged and cooled EGR	
No. of Cylinders	6	
Bore × Stroke	4.17 in. × 5.00 in. (106 mm × 127 mm)	
Displacement	415 cu. in. (6.8 liters)	
Rated Output	196 hp @ 1,800 rpm	
Starting	Electric	
Coolant Capacity	12.9 gal. (49.0 liters) ¹	
Lubricating Oil Capacity	8.58 gal. (32.5 liters) ²	
Lubricating Oil Type	API service class CJ-4, ACEA E9 or ACEA E6	
DEF Tank Capacity	29.7 gal. (112.4 liters)	
Fuel Type	#2 diesel fuel (ultra low sulfur diesel fuel only)	
Fuel Tank Capacity	319 gal. (1,210 liters)	
Fuel Consumption	8.9 gal. (33.7 L)/hr. at full load	7.2 gal. (27.3 L)/hr. at 3/4 load
	5.4 gal. (20.5 L)/hr. at 1/2 load	3.9 gal. (14.9 L)/hr. at 1/4 load
Battery	4D (CCA 0°F 1050A) × 1	

¹ Includes engine and radiator hoses. ² Includes filters.

DIMENSIONS

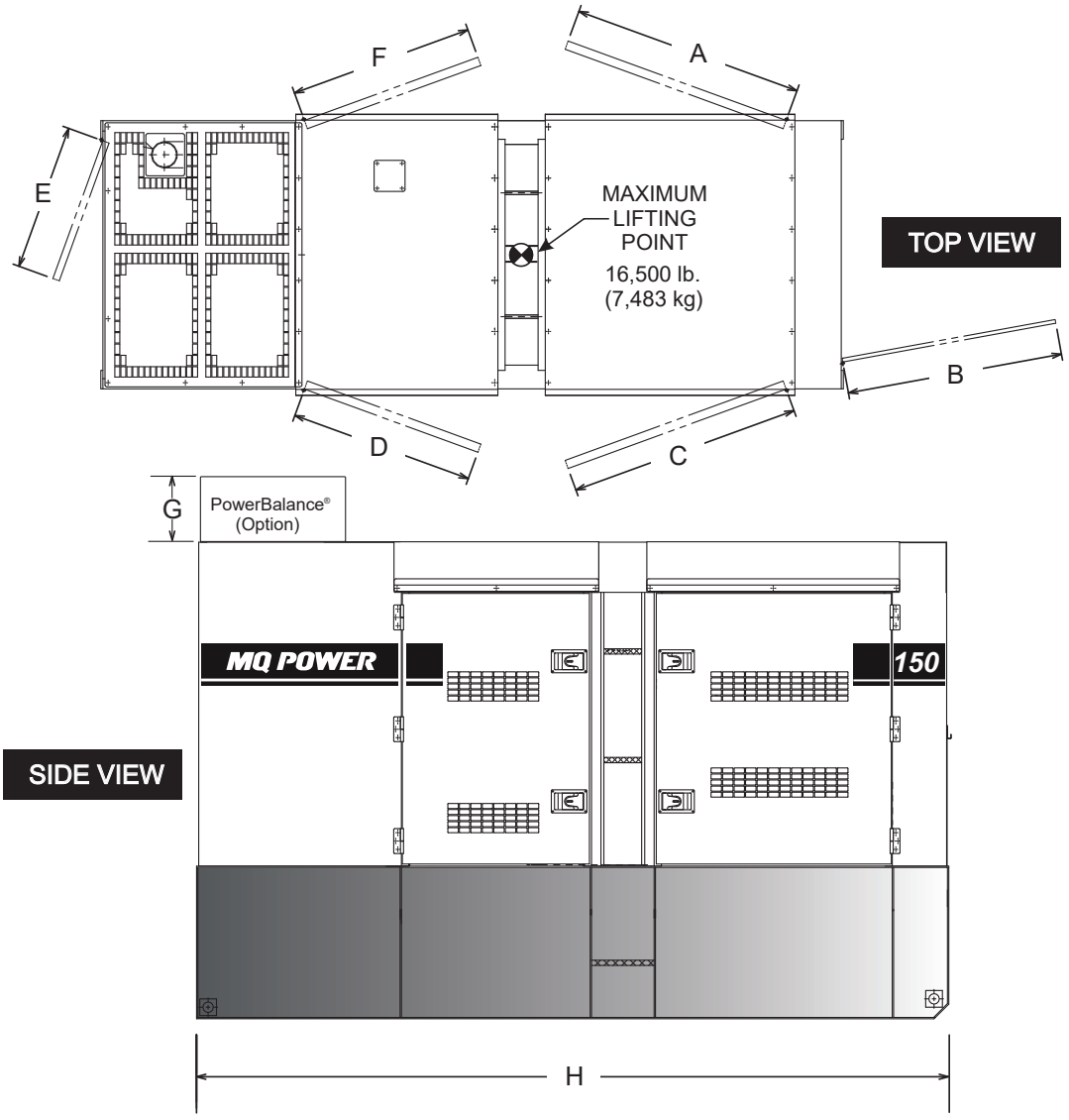
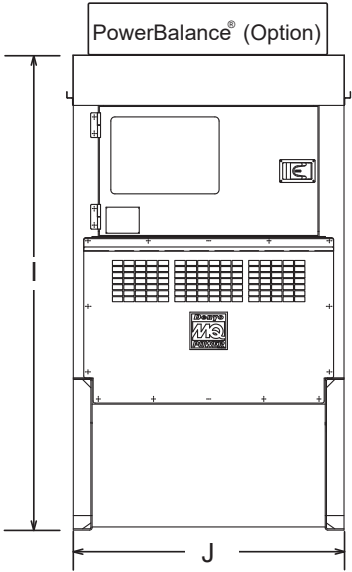

Figure 2. Dimensions



FRONT VIEW

Table 3. Dimensions			
Reference Letter	Dimension in. (mm)	Reference Letter	Dimension in. (mm)
A	44.29 (1,125)	F	35.24 (895)
B	41.34 (1,050)	G	11.38 (289)
C	44.29 (1,125)	H	141.73 (3,600)
D	35.24 (895)	I	88.19 in. (2,240)
E	27.95 (710)	J	51.18 in. (1,300)

GENERATOR GROUNDING

ALWAYS refer to Article 250 (Grounding and Bonding) of the National Electrical Code (NEC).

NOTICE

ALWAYS check with state, province, district, and municipalities for electrical grounding requirements before using the generator.

EXAMPLE of how to ground the unit (Figure 3) if the condition of use requires such a device:

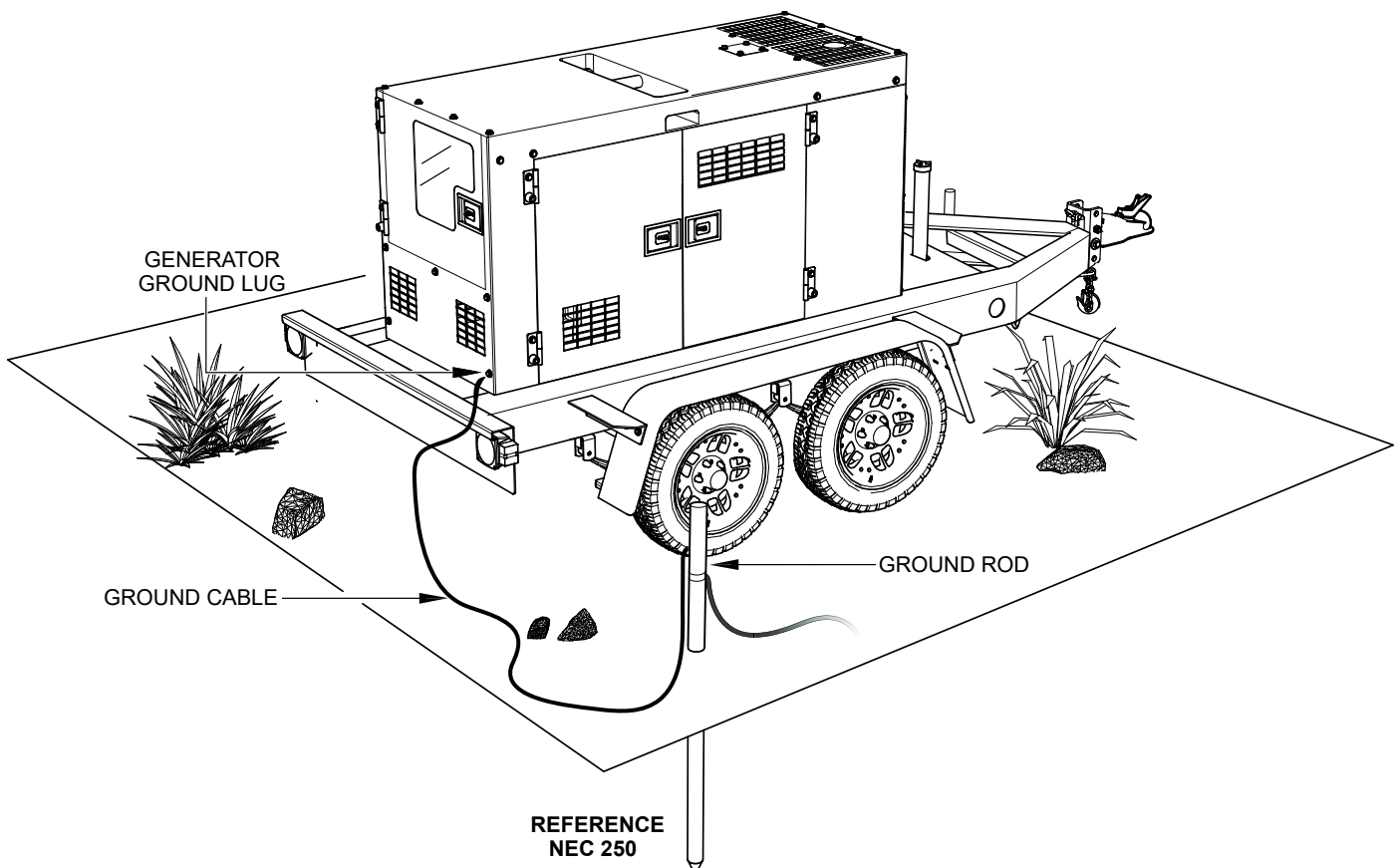

Figure 3. Typical Generator Grounding Application

NOTICE

Trailer-mounted generators are the sole responsibility of MQ Power.

OUTDOOR INSTALLATION

Install the generator in an area that is free of debris, bystanders, and overhead obstructions. Make sure the generator is on secure, level ground so that it cannot slide or shift around. Also, install the generator in a manner so that the exhaust will not be discharged in the direction of nearby homes.

The installation site must be relatively free from moisture and dust. All electrical equipment should be protected from excessive moisture. Failure to do so will result in deterioration of the insulation and will result in short circuits and grounding.

Foreign materials such as dust, sand, lint, and abrasive materials have a tendency to cause excessive wear to engine and alternator parts.

CAUTION

Pay close attention to ventilation when operating the generator inside tunnels and caves. The engine exhaust contains noxious elements. Engine exhaust must be routed to a ventilated area.

INDOOR INSTALLATION

Exhaust gases from diesel engines are extremely poisonous. Whenever an engine is installed indoors the exhaust fumes must be vented to the outside. The engine should be installed at least two feet from any outside wall. Using an exhaust pipe which is too long or too small can cause excessive back pressure which will cause the engine to heat excessively and possibly burn the valves.

MOUNTING

The generator must be mounted on a solid foundation (such as concrete) and set firmly on the foundation to isolate vibration of the generator when it is running. The generator must be mounted at least 6 inches above the floor or grade level as referenced in the National Fire Protection Association handbook (NFPA 110, Chapter 7, Section 7.4).

DO NOT remove the metal skids on the bottom of the generator. They are to resist damage to the bottom of the generator and to maintain alignment.

GENERAL INFORMATION

GENERATOR

This generator (Figure 5) is designed as a high-quality, portable (requires a trailer for transport) power source for telecom sites, lighting facilities, power tools, submersible pumps, and other industrial and construction machinery.

OPERATING PANEL

The “Operating Panel” is provided with the following:

- ECU-845 Controller (Standard)
- ECU-670 Gauge Unit Assembly
 - Oil Pressure Gauge
 - Water Temperature Gauge
 - Charging Voltmeter
 - Fuel Gauge
 - Tachometer
 - Generator Load
 - DEF Gauge
- Panel Light/Panel Light Switch
- Hour Check Button
- Auto Start/Stop Switch
- Engine Speed Switch
- Emergency Stop Switch
- Fuel Leak Detected Alarm Lamp
- Basler DGC-2020HD Digital Controller (Option)

GENERATOR

The “Generator” is provided with the following:

- Engine Block Heater
- PowerBalance® (Option)
- Battery Charger (Option)

CONTROL PANEL

The “Control Panel” is provided with the following:

- Frequency Meter (Hz)
- AC Ammeter (Amps)
- AC Voltmeter (Volts)
- Ammeter Change-Over Switch
- Voltmeter Change-Over Switch
- Hour Check Button
- Voltage Regulator
- 3-Pole, 400-Amp Main Circuit Breaker
- Panel Light
- Panel Light Switch
- “Control Box” (located behind Control Panel)
 - Automatic Voltage Regulator
 - Current Transformer
 - Overcurrent Relay
 - Starter Relay
 - Voltage Change-Over Board

OUTPUT TERMINAL PANEL

The “Output Terminal Panel” is provided with the following:

- Three 120/240V Output Receptacles (CS-6369), 50A
- Three Auxiliary Circuit Breakers, 50A
- Two 120V Output Receptacles (GFCI), 20A
- Two GFCI Circuit Breakers, 20A
- Five Output Terminal Lugs (3Ø Power)
- Ground Lug

OPEN-DELTA EXCITATION SYSTEM

Each generator is equipped with the state-of-the-art “Open-Delta” excitation system. The open-delta system consists of an electrically independent winding wound among stationary windings of the AC output section.

There are four connections of the open delta—A, B, C and D. During steady-state loads, the power from the voltage regulator is supplied from the parallel connections of A to B, A to D, and C to D. These three phases of the voltage input to the voltage regulator are then rectified and are the excitation current for the exciter section.

When a heavy load such as a motor starting or a short circuit occurs, the automatic voltage regulator (AVR) switches the configuration of the open delta to the series connection of B to C. This has the effect of adding the voltages of each phase to provide higher excitation to the exciter section and thus better voltage response during the application of heavy loads.

The connections of the AVR to the AC output windings are for sensing only. No power is required from these windings.

The open-delta design provides virtually unlimited excitation current, offering maximum motor-starting capabilities. The excitation does not have a “fixed ceiling” and responds according the demands of the required load.

ENGINE

This generator is powered by a 6-cylinder, 4-cycle, water-cooled, direct injection, turbocharged, EGR, John Deere 6068HFG06 diesel engine. This engine is designed to meet every performance requirement for the generator. Refer to Table 2 for engine specifications.

In keeping with MQ Power’s policy of constantly improving its products, the specifications quoted herein are subject to change without prior notice.

ELECTRIC GOVERNOR SYSTEM

The electric governor system controls the RPMs of the engine. When the engine demand increases or decreases, the governor system regulates the frequency variation to $\pm 0.25\%$.

EXTENSION CABLES

When electrical power is to be provided to various tools or loads at some distance from the generator, extension cords are normally used. Cables should be sized to allow for distance in length and amperage so that the voltage drop between the generator and point of use (load) is held to a minimum. Use the cable selection chart (Table 7) as a guide for selecting the proper extension cable size.

GENERAL PARALLELING INFORMATION (OPTION)

NOTICE

When the paralleling option is employed, the Basler DGC-2020HD controller **must** be installed. The factory installed ECU-845 controller cannot be used for paralleling.

PARALLELING

Paralleling is the sharing of a load between two generator sets or more.

LOAD SHARING

Load sharing is defined as the proportional division of the **kW** and **kVAR** total load between multiple generator sets in a paralleled system.

Load sharing is essential to avoid overloading and stability problems on the systems' generator sets.

ACTIVE POWER (KW) LOAD SHARING

When generator sets operate in parallel, the engine speed governor of each generator set determines the proportional sharing of the total **active** power requirements (kW) of the systems.

The kW load sharing is achieved by increasing or decreasing fuel to the systems' engines. As the fuel to the engine of one generator set in a group is increased it will not lead to an increase in speed and hence frequency (as it would if it were operating alone) but it will lead to an increase in the proportion of the total kW load that it will deliver.

As the fuel to the engine of one generator set in a group is decreased it will not lead to a decrease in speed and hence frequency (as it would if it were operating alone) but it will lead to a decrease in the proportion of the total kW load that it will deliver.

The control system of the generator sets (via the engine speed control system) monitors and controls the sharing of the total kW load in proportion to the relative rating of the engines on the systems' generator sets.

REACTIVE POWER (KVAR) LOAD SHARING

When generator sets operate in parallel, the **alternator field excitation** system of each generator set controls the proportional sharing of the total **reactive power requirements (kVAR)** of the system.

The kVAR load sharing is achieved by increasing or decreasing the field excitation to the systems' alternators.

As the field excitation of one generator set in a group is **increased** (i.e. over excited) it will **not** lead to an increase in voltage (as it would if it were operating alone) but it will lead to an increase in the proportion of the total **kVAR** load it will deliver and a decrease in its power factor.

As the field excitation of one generator set in a group is **decreased** (i.e. under excited) it will **not** lead to a decrease in voltage (as it would if it were operating alone) but it will lead to a decrease in the proportion of the total **kVAR** load it will deliver and an increase in its power factor.

An undesirable circulating **reactive current** (cross current) will flow in the system if the excitation of the alternators is not matched.

ETHERNET COMMUNICATION

Ethernet communication is the preferred method for paralleling. This method supports breaker negotiation to avoid simultaneous breaker closures, kW load sharing and kVAR sharing, and soft load transfers on and off loading.

The Ethernet ports are located at the output bus splash panel area. There are two ports which are identical so either one can be used. Using a standard Ethernet cable, interconnect units to be paralleled and or sequenced.

LOAD MANAGEMENT

These generators are set up to automatically manage load, based on demand. Load management is only functional in auto mode. While in **auto** mode, if the auto-start contacts are closed, load management is active by default. Load management will only run the number of units needed to support the load.

If the load demand is small, only one generator will remain running while the other generators will remain in standby mode. If the load increases above 80% of its capacity, it will start the next generator. The next generator priority is based on the time remaining on the maintenance timer.

Generators with more time until scheduled maintenance will take priority over units that are almost due for maintenance. Once the second unit starts it will synchronize and parallel in, then ramp up to share the load. If the load levels drop below 35% of its combined rating, the generator that is no longer needed will ramp off, shut down and wait in standby mode.

GENERAL PARALLELING INFORMATION (OPTION)

SEQUENCING

NOTICE

Ethernet communication is required when the generators are configured for the sequencing mode of operation.

These generators are capable of sequencing for control of balanced maintenance schedules. As described above, these generators can start and stop as demand increases or decreases. In addition, if a unit gets to the point of maintenance, it will ramp off and start the next generator to relieve it based on the time remaining on the maintenance timer.

After maintenance is performed, the maintenance timers should be reset to the recommended service interval. This is usually 250 hours depending on the engine oil type.

MAINTENANCE INTERVAL

Maintenance intervals are factory set for 250 hours. The maintenance interval timer will count down to zero indicating that it is time for the unit to be serviced.

Once the timer counts down to zero, a pre-alarm will appear indicating that the unit is due for maintenance. To reset the maintenance interval back to the default time of 250 hours, press and hold the “Reset” button for ten seconds.

To reset the maintenance interval using the reset button, the Maintenance Due Pre-Alarm must be active, and the Basler controller must display the “Overview Screen” (Main Screen).

If the maintenance timer has not yet expired and it is desired to reset the unit back to 250 hours, navigate back to the settings menu. Settings Menu->System Parameters->Engine Statistics->Hours To Maintenance.

ALARM SILENCE

Pre-Alarm Silence allows the user to suppress the toggling of the alarm screen when a new Pre-Alarm becomes active. While a Pre-Alarm is active, pressing the Alarm Silence button will suppress the fault display.

This happens to be a very handy function when the “Maintenance Interval” Pre-Alarm occurs. Right after the Pre-Alarm occurs it will begin toggling between the **pre-alarm** and the **overview screen**.

While in this mode, pressing the reset button does not reset the maintenance interval. In order to reset the maintenance interval the overview screen **must** be selected.

Pressing the alarm silence button will stop the toggling between the pre-alarm and the overview screen.

Once the overview screen is selected, the maintenance interval can be reset by pressing and holding the reset button for 10 seconds.

THREE PHASE 480V/208V PARALLEL WIRING VIA OPTIONAL CAM-LOKS

REQUIRED EQUIPMENT (USER SUPPLIED)

- Conductor Cables
- CAT5E Shielded Cable or Better
- Power Distribution Panel

The following procedure is intended to assist the user with the parallel wiring configuration for generators using the optional cam-lok connector panel.

NOTICE

Only a **qualified service technician** or **licensed electrician** with proper training should perform this installation. Follow all shop safety rules when performing this installation.

PREPARATION

1. Make sure the generator is turned off and the engine is cool.
2. Disconnect any loads connected to the generator.
3. Place the main circuit breaker in the **OFF** position.
4. Place the generator in an area free of dirt and debris. Make sure it is on secure, level ground.
5. Disconnect the **negative** battery cable from the battery.

GENERAL PARALLELING INFORMATION (OPTION)

3Ø-480 VAC PARALLEL WIRING CONFIGURATION

Use appropriately sized cables when connecting two generators to the power distribution panel. Refer to the NEC handbook for correct sizing of cables. Contact a licensed electrician for correct electrical wiring configuration.

⚠ DANGER

To prevent arcing make sure cables are securely tightened at the power distribution panel. The possibility exists of the unit catching on fire thus causing equipment damage and severe bodily harm.

NOTICE

When connecting load cables to the power distribution panel be sure to select the correct size of the load cables to handle full load/amperage of both generators (parallel).

3Ø-208 VAC PARALLEL WIRING CONFIGURATION

Use appropriately sized cables when connecting two generators to the power distribution panel. Refer to the NEC handbook for correct sizing of cables. Contact a licensed electrician for correct electrical wiring configuration.

ETHERNET CABLE CONNECTION

1. Connect a CAT5E Ethernet cable (shielded) between port 1 on both generators as shown in Figure 4.

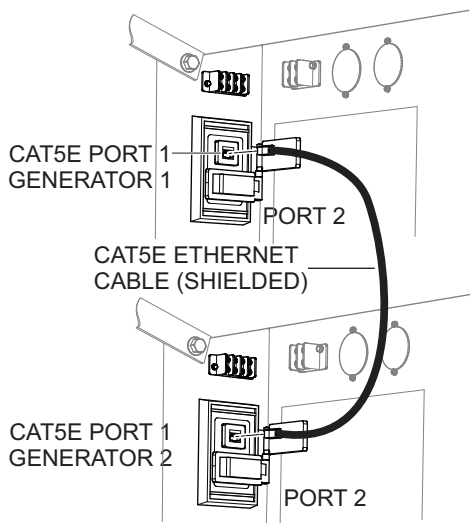

Figure 4. Ethernet Cable Connection

2. Refer to Table 4 for additional Ethernet port connections.

Table 4. Ethernet Cable Connections

Generator 1	Generator 2
Port 2	Port 1
Port 1	Port 2
Port 2	Port 2

3. Reconnect the battery.
4. Start the generator as outlined in the start-up section of this manual.

MAJOR COMPONENTS

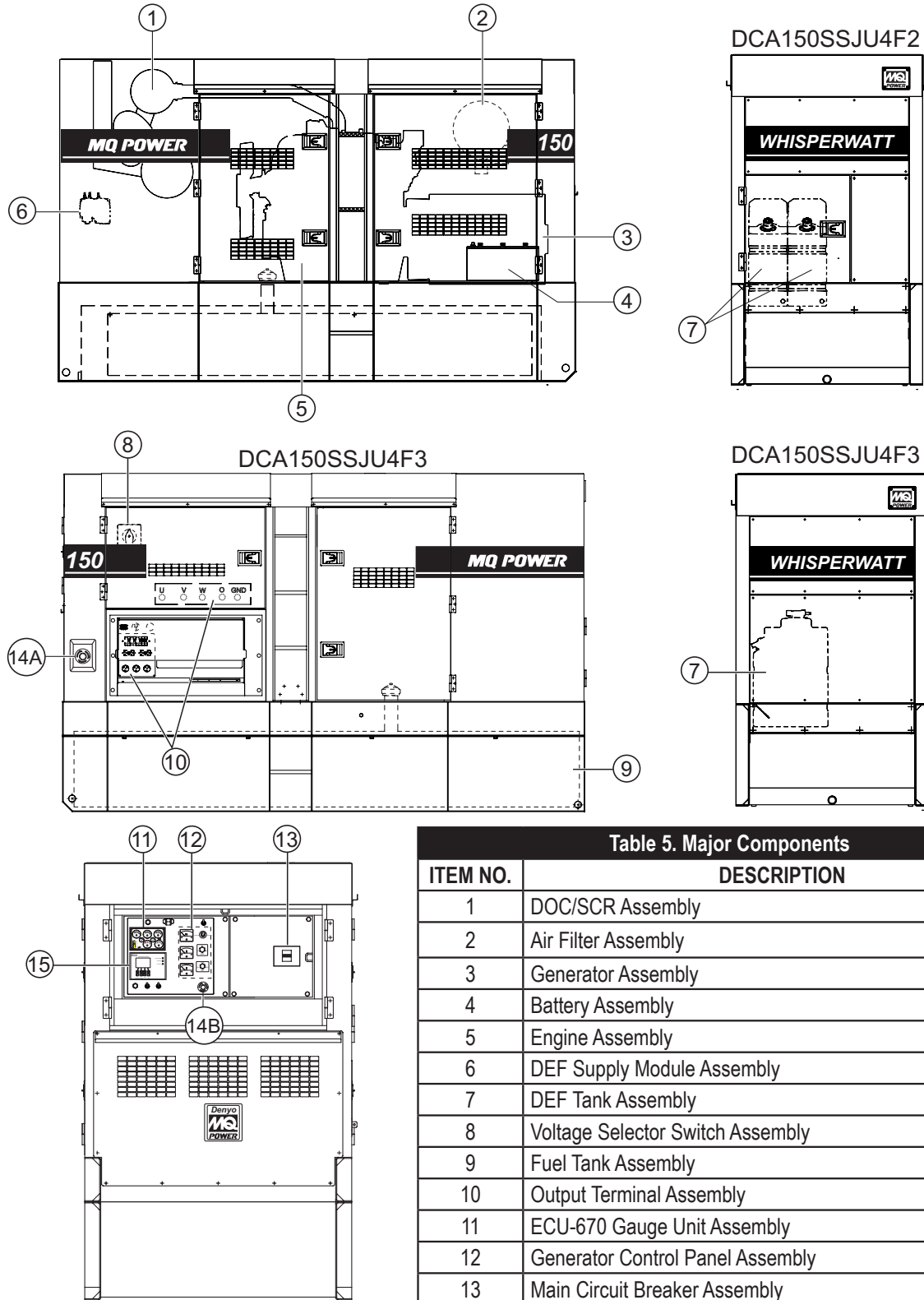

Figure 5. Major Components

Table 5. Major Components	
ITEM NO.	DESCRIPTION
1	DOC/SCR Assembly
2	Air Filter Assembly
3	Generator Assembly
4	Battery Assembly
5	Engine Assembly
6	DEF Supply Module Assembly
7	DEF Tank Assembly
8	Voltage Selector Switch Assembly
9	Fuel Tank Assembly
10	Output Terminal Assembly
11	ECU-670 Gauge Unit Assembly
12	Generator Control Panel Assembly
13	Main Circuit Breaker Assembly
14A	E-Stop Switch Assembly S/N 7601333 and above (F3)
14B	E-Stop Switch Assembly S/N 7601332 and below (F3)
	E-Stop Switch Assembly (F2)
15	ECU-845 Controller Assembly

ENGINE CONTROL UNIT (ECU-845)

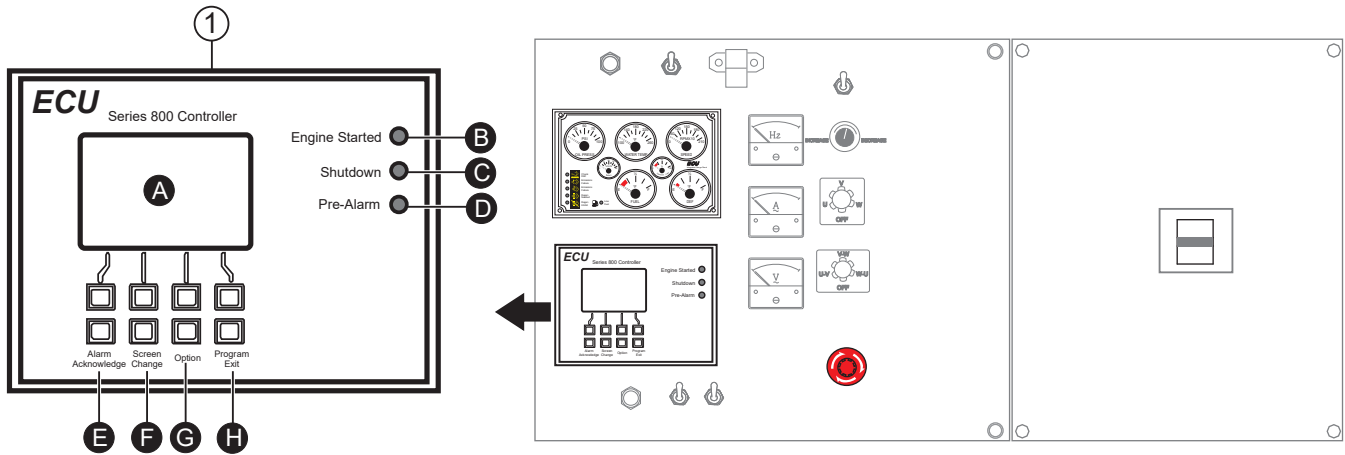

Figure 6. Engine Control Unit (ECU-845)

The definitions below describe the controls and functions of the Engine Control Unit (Figure 6).

1. **ECU-845 Controller** — This auto start/stop controller displays the parameters and the diagnostic troubleshooting messages of the engine.

In addition, this controller also displays symbols and indications related to the exhaust gas after treatment system (DOC, SCR) including the diesel exhaust fluid (DEF) level in the DEF tank.

- ECU Display Screen** — Engine fault diagnostic messages are shown on this LCD display screen.
- Engine Started Lamp** — This lamp when lit indicates the engine is operating normally.
- Engine Shutdown Lamp** — When an engine failure has occurred this lamp will blink, indicating the engine has been shut down. The diagnostic fault message will be displayed on the LCD screen.
- Pre-Alarm Lamp** — When an engine failure has occurred this lamp will blink, indicating a pre-fault engine condition and the possibility of engine shutdown. The diagnostic fault message will be displayed on the LCD screen.
- Alarm Acknowledge Button** — When the engine experiences a fault, the “Pre Alarm Lamp” or the “Shutdown Lamp” will start blinking. Pushing this button will confirm the fault message and the blinking lamp will change to a solid lamp display.

The fault message will be displayed on the screen. When multiple engine faults occur, the lamp will continue blinking until all fault messages are confirmed. The blinking lamp will change to a solid lamp display and all current confirmed fault messages will scroll across the screen.

- Screen Change Button** — When this button is pushed during operation, the screen (Figure 7) will cycle through main and secondary parameter screens.

VOLTS		AMPS
UO 278	UV 480	U 180
VO 278	VW 480	V 180
WO 278	WU 480	W 180
120.0 kW		150.0 kVA
60.0 Hz		100.0 h

ENGINE GENERATOR SYSTEM OK

Figure 7. Generator Parameter Screen

NOTICE

The screen as shown in (Figure 7) represents the phase voltages for each phase to neutral (UO, VO and WO) and the line voltages between each phase (UV, VW and WU).

- Option Button** — This button is not active. Do not use.
- Program/Exit Button** — Push this button from the home screen to enter the main menu.

GAUGE UNIT ASSEMBLY (ECU-670)

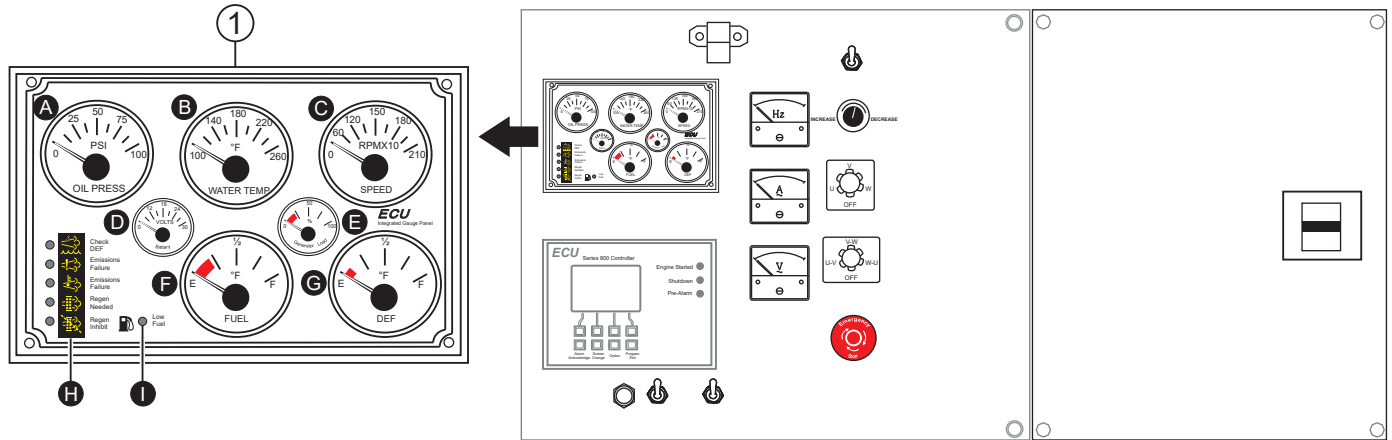

Figure 8. Gauge Unit Assembly

The definitions below describe the readouts and functions of the Gauge Unit Assembly (Figure 8).

1. **ECU-670 Gauge Unit Assembly** — This assembly houses the various engine monitoring gauges: oil pressure, water temperature, charging voltmeter, generator load, fuel level, DEF level, and engine speed (tachometer).
 - A. **Oil Pressure Gauge** — During normal operation, this gauge should read approximately 46 psi (317 kPa). When starting the generator, the oil pressure may read a little higher but after the engine warms up, the oil pressure should return to the correct pressure range.
 - B. **Water Temperature Gauge** — During normal operation this gauge should read between 185° and 207°F (85°–97°C).
 - C. **Tachometer** — Indicates engine speed in RPM for 60 Hz operation. This meter should indicate 1,800 RPM when the rated load is applied.
 - D. **Battery Voltmeter Gauge** — During normal operation this gauge indicates a minimum 14 VDC.
 - E. **Generator Load Gauge** — Indicates the generator load rate. It is recommended the load be above the red area (20%) for maintaining sufficient exhaust temperature.
 - F. **Fuel Gauge** — Indicates the amount of diesel fuel available. The red area on the gauge indicates a low fuel level (20%).
 - G. **DEF Gauge** — Indicates the amount of diesel exhaust fluid available. The red area on the gauge indicates a low DEF level (10%).
 - H. **Exhaust System State Indicator Lamps** — Lamps illuminate when the engine is at Exhaust System State or DEF state. Refer to the maintenance section of this manual for more detailed information.
 - I. **Low Fuel Warning LED** — When ON (lit) indicates that the fuel level is low.

ENGINE/GENERATOR CONTROL PANEL

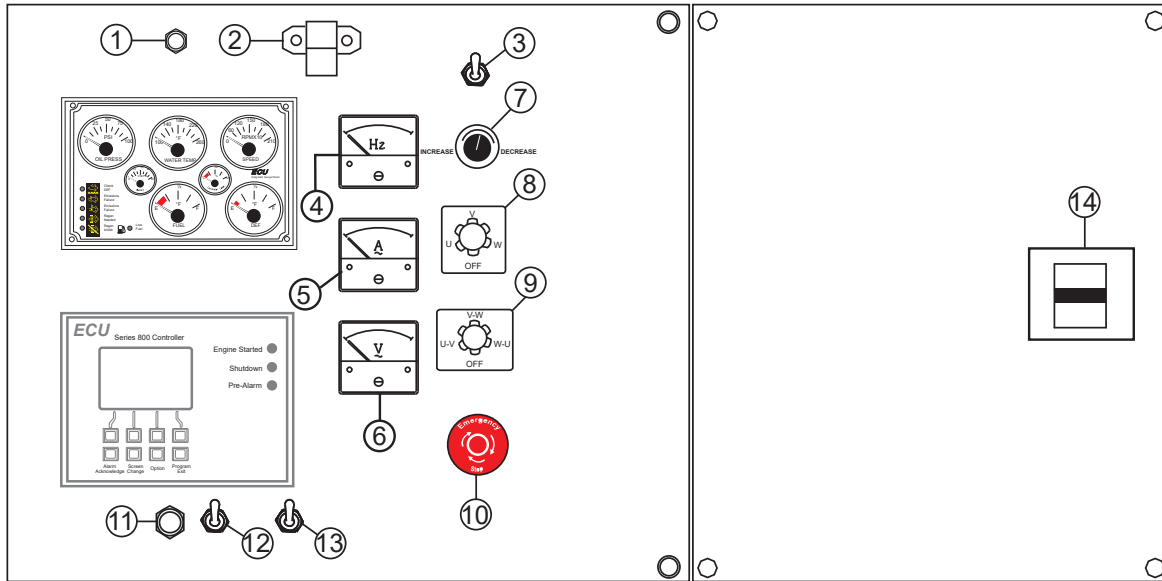

Figure 9. Engine/Generator Control Panel

The definitions below describe the controls and functions of the Engine/Generator Control Panel (Figure 9).

1. **Fuel Leak Alarm Lamp** — This lamp turns on when the fluid in the containment tank is higher than the allowable level.
2. **Panel Light** — For operation at night, the panel light illuminates the control panel for ease of reading meters and gauges. Make sure the panel light switch is in the OFF position when the light is not needed.
3. **Panel Light Switch** — When activated will turn on the control panel light.
4. **Frequency Meter** — Indicates the output frequency in hertz (Hz). Normally 60 Hz.
5. **AC Ammeter** — Indicates the amount of current the load is drawing from the generator per leg selected by the ammeter phase-selector switch.
6. **AC Voltmeter** — Indicates the output voltage present at the **U,V, and W output terminal lugs**.
7. **Voltage Regulator Control** — Allows $\pm 15\%$ manual adjustment of the generator's output voltage.
8. **Ammeter Change-Over Switch** — This switch allows the AC ammeter to indicate the current flowing to the load connected to any phase of the output terminals, or to be switched off. This switch does not affect the generator output in any fashion, it is for current reading only.
9. **Voltmeter Change-Over Switch** — This switch allows the AC voltmeter to indicate phase-to-phase voltage between any two phases of the output terminals or to be switched off.
10. **Emergency Stop Switch Button** — In the event of an emergency, press this button to shut down the generator. On DCA150SSJU4F3 models S/N 7601333 and above, this switch is located on the outside of the enclosure.
11. **Hour Check Button** — With the engine stopped, press and hold this button to display total running hours, fuel level, and battery voltage.
12. **Auto Start/Stop Switch** — This switch selects either manual or automatic operation. Center position is OFF (reset).
13. **Engine Speed Switch** — This switch controls the speed of the engine, low or high.
14. **Main Circuit Breaker** — This three-pole, 400-amp main breaker is provided to protect the **U,V, and W output terminal lugs** from overload.

BASLER DIGITAL GENSET CONTROLLER (OPTION)

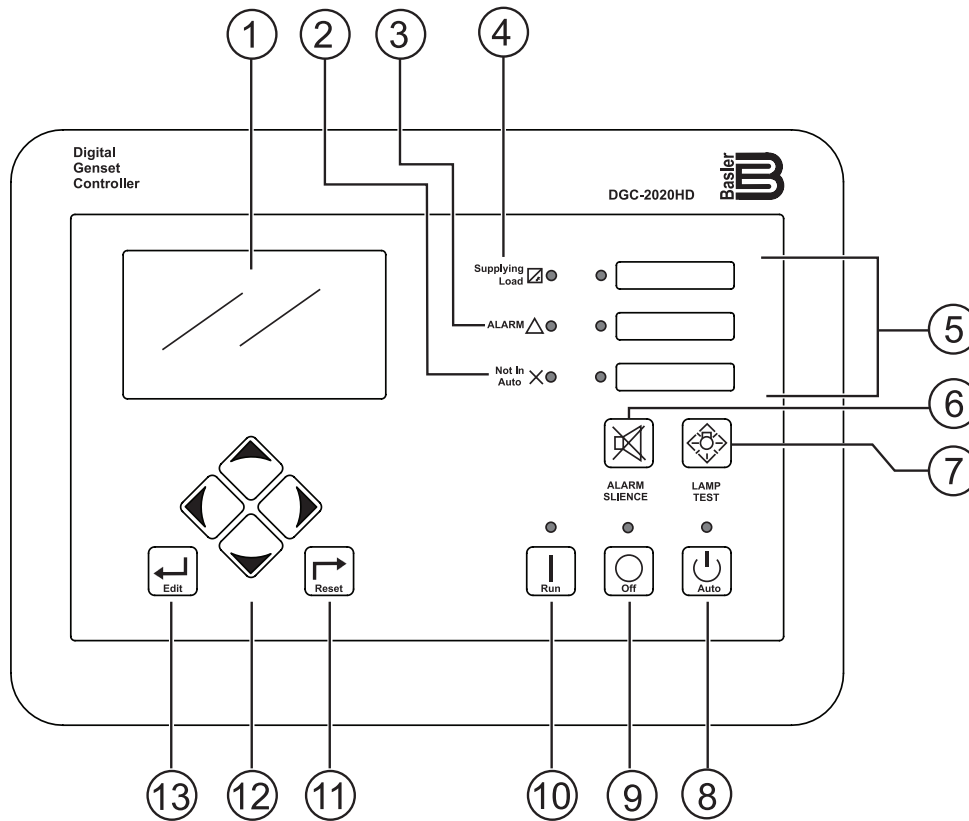

Figure 10. Basler DGC-2020HD

NOTICE

The Basler DGC-2020HD controller is an **option**. It replaces the standard ECU-845 controller when the paralleling option is employed.

BASLER DIGITAL GENSET CONTROLLER (OPTION)

The definitions below describe the controls and functions of the Digital Genset Controller (Figure 10).

1. **LCD Display** — Display consists of an LCD **color touch screen**. The backlit, 272 × 480-pixel color LCD serves as the local information source for metering, alarms, pre-alarms, and protective functions. Touch screen capability provides convenient navigation through metering and settings. Display operation is maintained down to -4°F (-20°C).
2. **Not In Auto Indicator** — This red LED lights when the DGC-2020HD is **not** operating in **Auto mode**.
3. **Alarm Indicator** — This red LED lights continuously during alarm conditions and flashes during pre-alarm conditions.
4. **Supplying Load Indicator** — This green LED lights when the generator current is greater than the emergency power supply (EPS) threshold current.
5. **Voltage Selection Indicators** — These three LEDs light to indicate the selected voltage. The **upper** lamp indicates **3-phase, 480-volt** operation. The **middle** lamp indicates **3-phase, 240-volt** operation. The **lower** lamp indicates **idle running** operation.
6. **Alarm Silence Pushbutton** — Press this button to open the relay output programmed as the horn output.
7. **Lamp Test Pushbutton** — Press this button to test the DGC-2020HD indicators by exercising all LCD pixels and lighting all LEDs.
8. **Auto Pushbutton and Mode Indicator** — Press the **Auto button** to place the DGC-2020HD in **Auto mode**. The green **Auto Mode LED** lights when Auto mode is active.

While in Auto mode, if the unit's auto-start contacts are connected to a transfer switch and the contacts between the terminals are closed, the unit will start and automatically close the circuit breaker.

If running in parallel, the Basler controller will command the unit to start and close the breaker based on load demand. If a failure occurs with another generator in the paralleled system, the controller will start and synchronize, then close the motorized breaker to electrically lock the unit in parallel.

If the bus is dead it will immediately close the circuit breaker to provide power to the load(s). If the bus is already hot from another generator it will first synchronize, then close its breaker, then slowly ramp up to share load if load is present.

9. **Off Pushbutton and Mode Indicator** — Press this button to place the DGC-2020HD in **Off mode**. The red **Off Mode LED** lights whenever the DGC-2020HD is in Off mode.
10. **Run Pushbutton and Mode Indicator** — Press this button to place the DGC-2020HD in **Run mode**. The green **Run Mode LED** lights whenever Run mode is active.
11. **Reset Pushbutton** — Press this button to cancel a settings editing session and discard any settings changes. When held, this button resets the **Breaker Management pre-alarms**. This button is also used to reset the maintenance interval when pressed for 10 seconds while viewing **Hours Until Maintenance** or the **Maintenance Due pre-alarm**.
12. **Arrow Pushbuttons** — These four buttons are used to navigate through the front panel display menus and to modify settings.
 - The **Left Arrow and Right Arrow buttons** are used to navigate through the menu levels. Press the **Right Arrow button** to move **downward** through the menu levels and press the **Left Arrow button** to move **upward** through the menu levels.
 - The **Up Arrow and Down Arrow buttons** are used to move among items within a menu level. Press the **Down Arrow button** to move to items lower on the list. Press the **Up Arrow button** to move to items higher on the list.
 - During a settings editing session, the Up Arrow and Down Arrow buttons are used to increase and decrease the value of the selected setting. The Right Arrow and Left Arrow buttons move to different digits.
13. **Edit Pushbutton** — Press the **Edit pushbutton** to start an editing session and enable changes to the DGC-2020HD settings. At the conclusion of an editing session, press this button again to save the setting changes.

PARALLELING PANEL (OPTION)

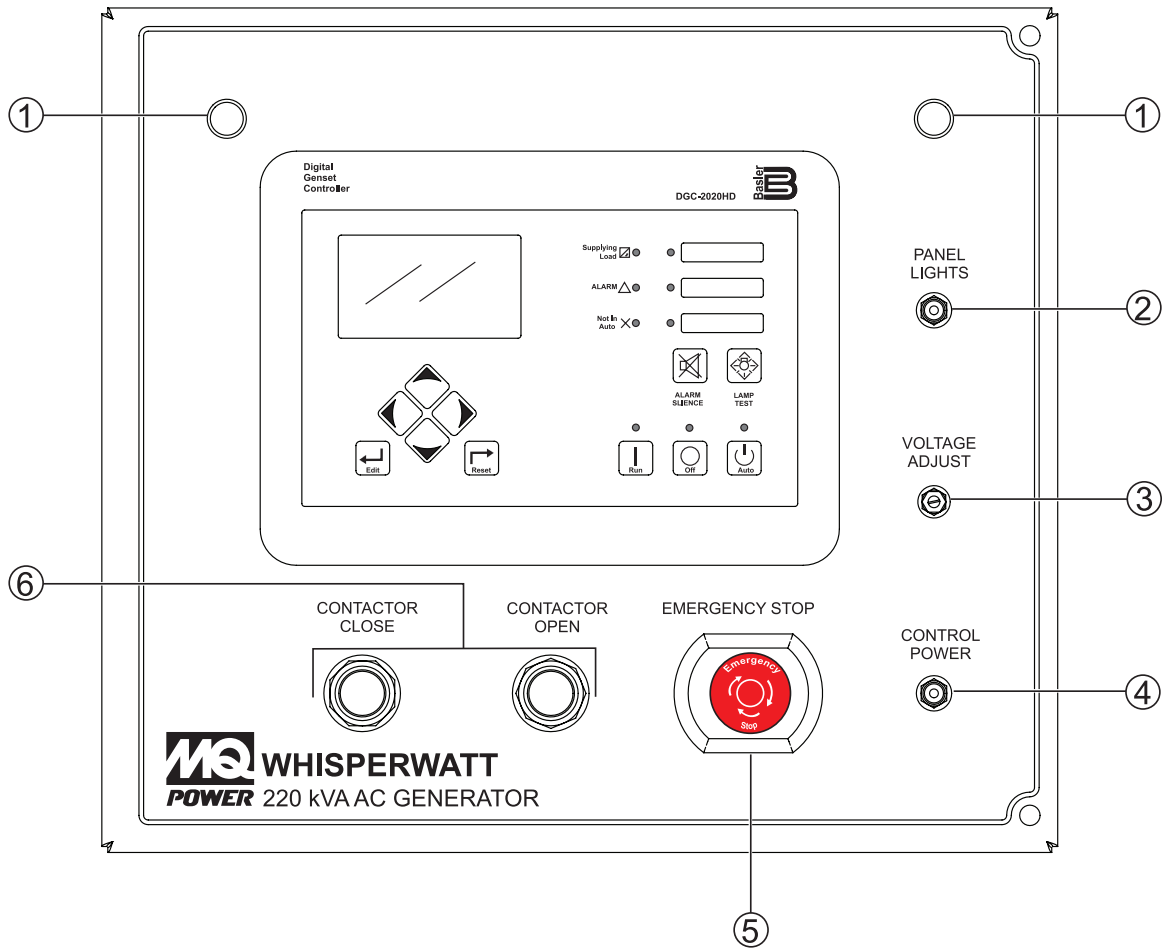

Figure 11. Paralleling Panel Components

PARALLELING PANEL (OPTION)

The definitions below describe the controls and functions of the Paralleling Panel (Figure 11).

1. **Panel Lights** — For operation at night or in dark areas, the panel lights illuminate the paralleling panel for ease of reading.
2. **Panel Light Switch** — When activated, will turn on the control panel lights.
3. **Voltage Adjust Potentiometer** — The **voltage adjust potentiometer** is a way to adjust the voltage up or down for fine tuning. The adjustment sends a signal to the controller to offset the system rated voltage (trim voltage). It is important that all machines are set to the same value when paralleling.

When first turning on the control power, the controller will begin its boot sequence much like a computer does. After completing the boot sequence the unit will be ready to run or be placed in auto mode for auto-start applications.

4. **Control Power Toggle Switch** — The control power switch is a master power switch for the digital controller. The control power switch has a latch feature that prevents powering down control power while the engine is running.
5. **Emergency Stop Button Switch** — The Emergency Stop pushbutton switch is used to stop the engine in case of emergency or to lock out operation during service. The emergency stop button **should not be used for routine stopping of the engine**.

Actuation of the Emergency stop button while the control power is on will illuminate the light on the button as well as display “Emergency Stop” on the controller display. Actuating the Emergency stop button will de-energize all controller outputs and cause the engine to stop as well as trip the circuit breaker. This condition is a latched condition that must be reset prior to restarting the engine.

The procedure for resetting the emergency stop requires several actions. Rotate the emergency stop button to release the spring latch. To clear the latch, the controller must be placed in the off mode by pressing the “OFF” button. While in the “OFF” mode, the “RESET” button must be pressed to clear the E-STOP fault.

For units with manually operated breakers, the breaker will need to be reset by toggling the handle down, then can be turned back to the “ON” position. On models with spring-charged breakers resetting the breaker is not necessary.

6. **Contactor Operation (Manual Mode)** — For manual run applications, user action is required to get the generator power to the output bus. Depending on the model, some utilize contactors in series with toggle-handle circuit breakers while others have spring-charged automatic circuit breakers.

On the spring-charged types, the buttons on the breaker itself are not intended for circuit breaker operation. For instructional purposes both will be referred to as “contactor.”

There are two pushbuttons on the control panel for controlling the contactor. There is a green “CLOSE CONTACTOR” button to close the contactor and a red “OPEN CONTACTOR” button to open the contactor. These buttons illuminate to show the contactor status. If the contactor is open, the red “OPEN CONTACTOR” button will be illuminated. If the contactor is closed the green “CLOSE CONTACTOR” button will be illuminated.

These buttons can sometimes be multifunctional depending on the situation. For stand-alone operation the buttons simply close and open the contactor as expected. For paralleling the buttons can act a little different.

When the bus is already hot from another generator, pressing the green online button will initiate a synchronizing sequence before closing the contactor. There will be an image of a synchroscope on the controller display and when the voltage and phases are matched, the contactor will close.

If there was already load on the bus the unit will slowly ramp up load until it is sharing equally with the other generator(s). While sharing load with other generators, pressing the red “OPEN CONTACTOR” button once will initiate a ramp-down sequence. The unit will begin to ramp down and when at a low level of load it will automatically open its contactor. Pressing the red “OPEN CONTACTOR” button twice will immediately open the contactor.

OUTPUT TERMINAL PANEL FAMILIARIZATION

OUTPUT TERMINAL PANEL

The Output Terminal Panel (Figure 12) shown below is provided for the connection of electrical loads. Lift up on the cover to gain access to receptacles and terminal lugs.

NOTICE

Terminal O is neutral bonded to the ground from the factory.

NOTICE

Output Terminal Bolt Torque: 554.9 lbf-in (62.7 N-m)

OUTPUT TERMINAL FAMILIARIZATION

The “Output Terminal Panel” is provided with the following:

- Three (3) 240/120V Output Receptacles @ 50 amps
- Three (3) Circuit Breakers @ 50 amps
- Two (2) 120V GFCI Receptacles @ 20 amps
- Two (2) GFCI Circuit Breakers @ 20 amps
- Five (5) Output Terminal Lugs (U, V, W, O, Ground)

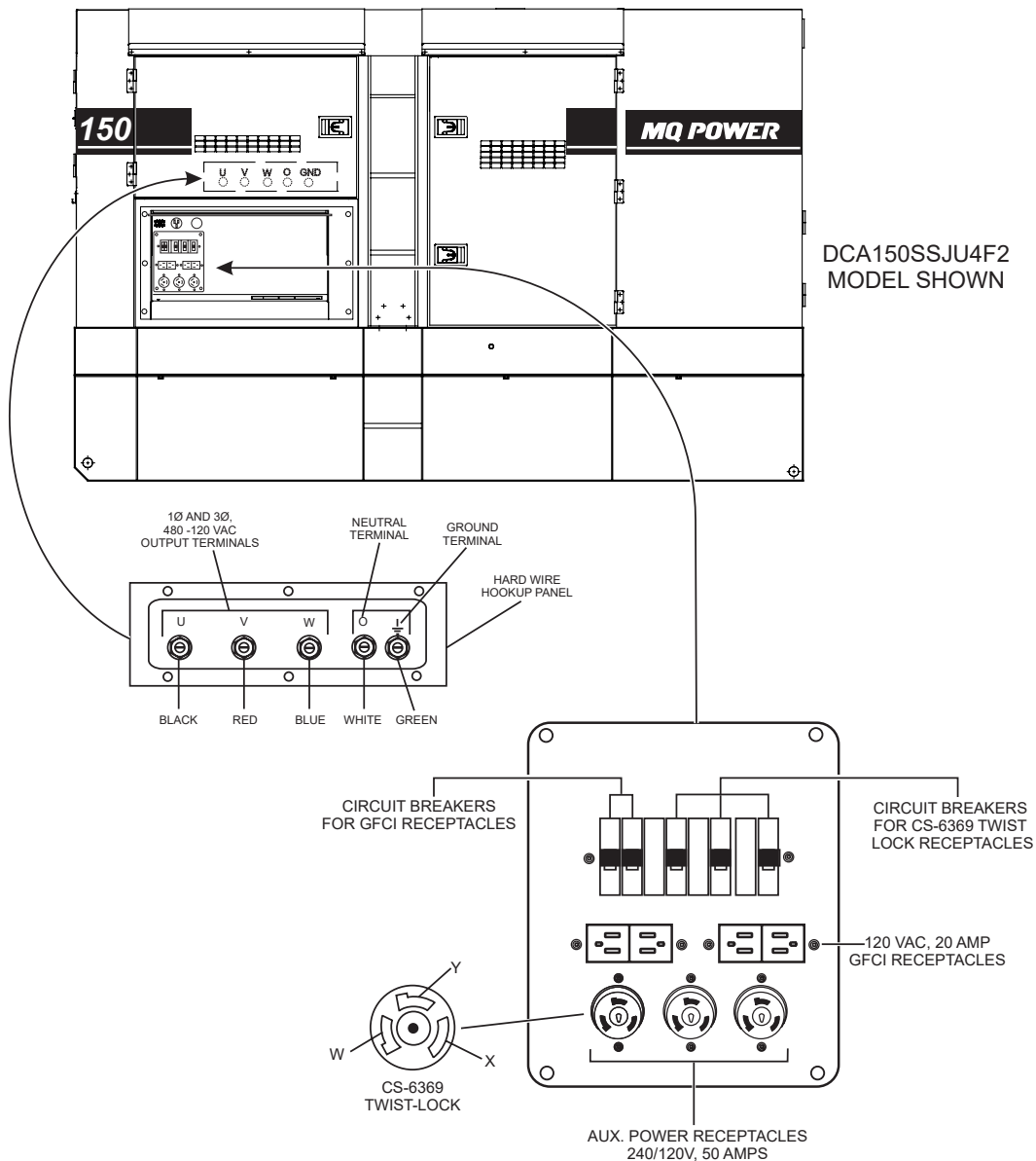

Figure 12. Output Terminal Panel

OUTPUT TERMINAL PANEL FAMILIARIZATION

120 VAC GFCI Receptacles

NOTICE

It is recommended that the GFCI receptacles be tested when the generator is initially uncrated. The receptacles should then be tested daily at startup.

There are two 120 VAC, 20-amp GFCI (duplex NEMA 5-20R) receptacles provided on the output terminal panel. These receptacles can be accessed in any **voltage selector switch** position. Each receptacle is protected by a 20-amp circuit breaker. These breakers are located directly above the GFCI receptacles. Remember the load output (current) of both GFCI receptacles is dependent on the load requirements of the U, V, and W output terminal lugs.

Pressing the **reset** button resets the GFCI receptacle after being tripped. Pressing the **test button** (See Figure 13) in the center of the receptacle will check the GFCI function. Both receptacles should be tested at least once a month. Reference the maintenance section in this manual for further testing of the GFCI receptacle.

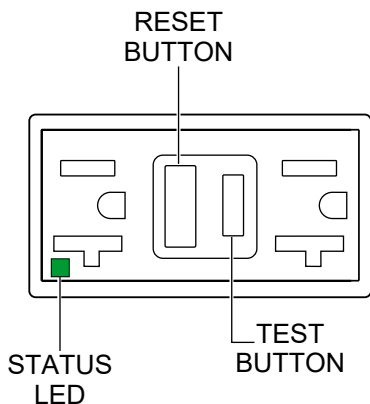

Figure 13. 120 VAC GFCI Receptacle

Twist-Lock Dual-Voltage 240/120 VAC Receptacles

There are three 240/120-volt, 50-amp, auxiliary twist-lock (CS-6369) receptacles (Figure 14) provided on the output terminal panel. These receptacles can **only** be accessed when the voltage selector switch is configured for **single-phase 240/120-volt** application.

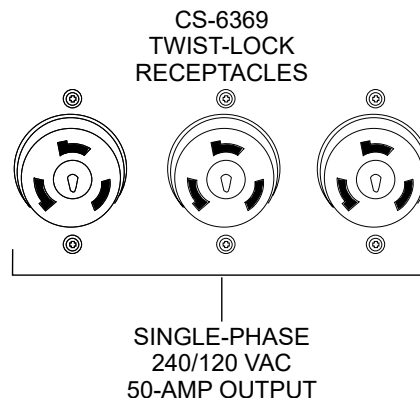

Figure 14. 240/120V Twist-Lock Auxiliary Receptacles

Each auxiliary receptacle is protected by a 50-amp circuit breaker. These breakers are located directly above the GFCI receptacles. Remember the load output (current) on all three receptacles is dependent on the load requirements of the **output terminal lugs**.

Removing The Plastic Face Plate (Hard Wire Hookup Panel)

The output terminal lugs are protected by a plastic face plate cover (Figure 15). Unscrew the securing bolts and lift the plastic terminal cover to gain access to the terminal enclosure.

After the load wires have been securely attached to the terminal lugs, reinstall the plastic face plate.

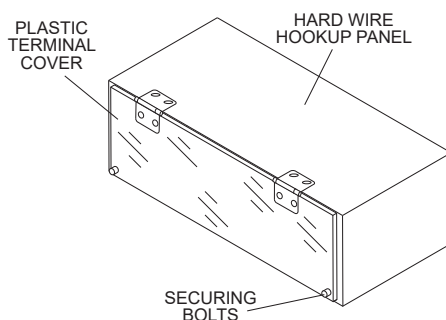

Figure 15. Plastic Face Plate (Output Terminal Lugs)

OUTPUT TERMINAL PANEL FAMILIARIZATION

Connecting Loads

Loads can be connected to the generator via the output terminal lugs, convenience receptacles, or optional cam-locks (Figure 16). Make sure to read the operation manual before attempting to connect a load to the generator.

To protect the output terminals from overload, a 3-pole, 400-amp **main** circuit breaker is provided. Make sure to switch **ALL** circuit breakers to the **OFF** position prior to starting the engine.

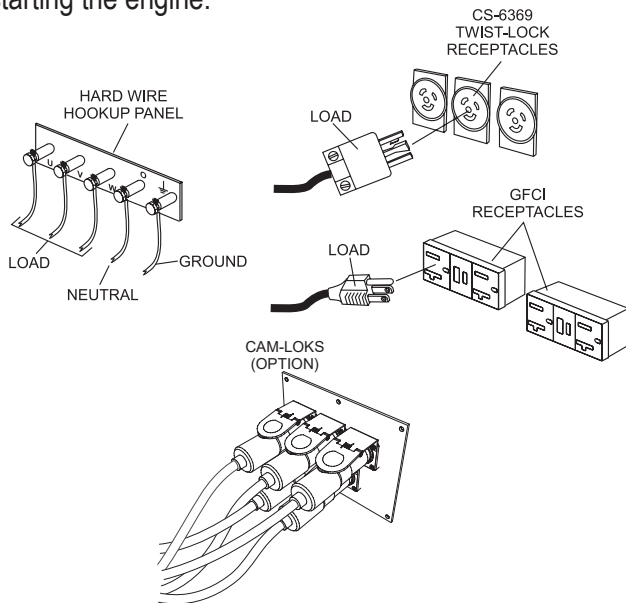

Figure 16. Connecting Loads

Overcurrent Relay

An **overcurrent relay** (Figure 17) is connected to the main circuit breaker. In the event of an overload, both the circuit breaker and the overcurrent relay may trip. If the circuit breaker can not be reset, the **reset button** on the overcurrent relay must be pressed. The overcurrent relay is located inside the control box.

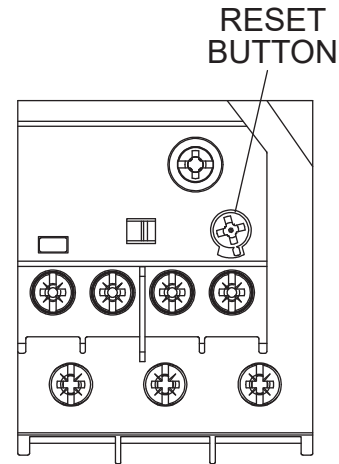

Figure 17. Overcurrent Relay

NOTICE

Remember the **overcurrent relay** monitors the current flowing from the **U, V, and W output terminal lugs** to the load.

In the event of a short circuit or overcurrent condition, it will automatically trip the 400-amp main breaker.

To restore power to the **output terminal panel**, press the reset button on the overcurrent relay and place the **main** circuit breaker in the **closed** position (**ON**).

LOAD APPLICATION

SINGLE-PHASE LOAD

Always be sure to check the nameplate on the generator and equipment to ensure the wattage, amperage, frequency, and voltage requirements are satisfactorily supplied by the generator for operating the equipment.

Generally, the wattage listed on the nameplate of the equipment is its rated output. Equipment may require 130–150% more wattage than the rating on the nameplate, as the wattage is influenced by the efficiency, power factor, and starting system of the equipment.

NOTICE

If wattage is not given on the equipment's nameplate, approximate wattage may be determined by multiplying nameplate voltage by the nameplate amperage.

$$\text{WATTS} = \text{VOLTAGE} \times \text{AMPERAGE}$$

The power factor of this generator (single phase) is 1.0. See Table 6 below when connecting loads.

Table 6. Power Factor By Load

Type of Load	Power Factor
Single-phase induction motors	0.4–0.75
Electric heaters, incandescent lamps	1.0
Fluorescent lamps, mercury lamps	0.4–0.9
Electronic devices, communication equipment	1.0
Common power tools	0.8

Table 7. Cable Selection (60 Hz, Single-Phase Operation)

Current in Amperes	Load in Watts		Maximum Allowable Cable Length			
	At 100 Volts	At 200 Volts	#10 Wire	#12 Wire	#14 Wire	#16 Wire
2.5	300	600	1,000 ft.	600 ft.	375 ft.	250 ft.
5	600	1,200	500 ft.	300 ft.	200 ft.	125 ft.
7.5	900	1,800	350 ft.	200 ft.	125 ft.	100 ft.
10	1,200	2,400	250 ft.	150 ft.	100 ft.	
15	1,800	3,600	150 ft.	100 ft.	65 ft.	
20	2,400	4,800	125 ft.	75 ft.	50 ft.	

CAUTION: Equipment damage can result from low voltage.

THREE-PHASE LOAD

When calculating the power requirements for 3-phase power, use the following equation:

$$\text{KVA} = \frac{\text{VOLTAGE} \times \text{AMPERAGE} \times 1.732}{1000}$$

NOTICE

If 3Ø load (kVA) is not given on the equipment nameplate, approximate 3Ø load may be determined by multiplying voltage by amperage by 1.732.

NOTICE

Motors and motor-driven equipment draw much greater current for starting than during operation.

An inadequately sized connecting cable which cannot carry the required load can cause a voltage drop which can burn out the appliance or tool and overheat the cable. See Table 6.

The power factor of this generator (3 phase) is 0.8.

- When connecting a resistance load such as an incandescent lamp or electric heater, a capacity of up to the generating set's rated output (kW) can be used.
- When connecting a fluorescent or mercury lamp, a capacity of up to the generating set's rated output (kW) multiplied by 0.6 can be used.
- When connecting an electric drill or other power tools, pay close attention to the required starting current capacity.

When connecting ordinary power tools, a capacity of up to the generating set's rated output (kW) multiplied by 0.8 can be used.

DANGER

Before connecting this generator to any building's electrical system, a **licensed electrician** must install an **isolation (transfer) switch**. Serious damage to the building's electrical system may occur without this transfer switch.

PowerBalance® (Figure 18) is an optional load management solution that helps protect the engine generator from problems resulting from sustained low-load operations (defined as less than 30% of the generator full-load rating).

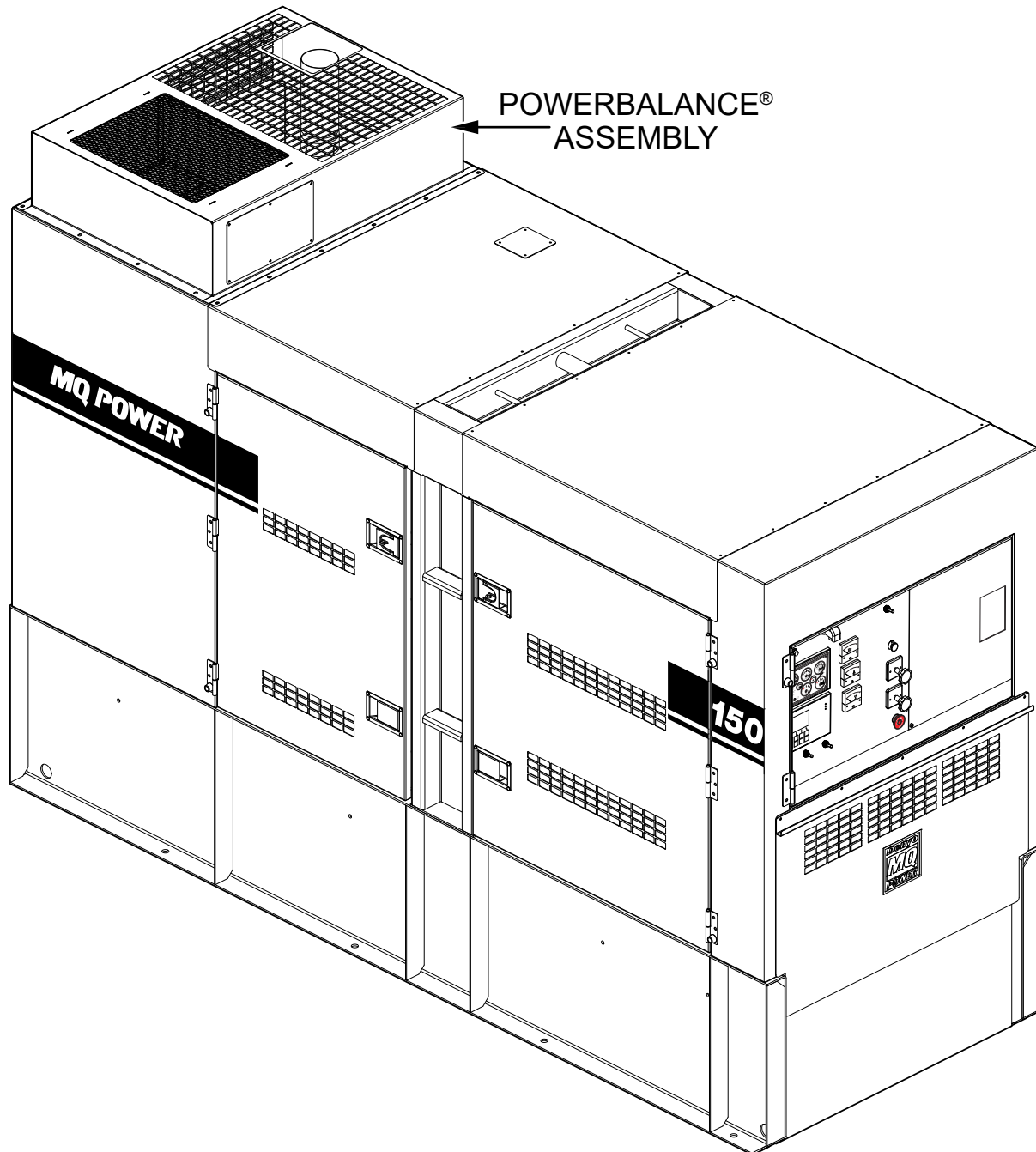

Figure 18. PowerBalance®

- PowerBalance® continuously monitors engine load. The load management controller senses and increases engine load automatically using resistive coils when the controller determines that the temperature and/or load is too low.
- When additional load demands are placed on the generator that bring it to an optimum level, PowerBalance® will automatically deactivate this additional load and remain ready for reactivation should exhaust temperatures drop.

GENERATOR OUTPUTS

GENERATOR OUTPUT VOLTAGES

A wide range of voltages (Table 8) is available for many different applications.

Table 8. Voltages Available						
UVWO Output Terminal Lugs	Voltage Selector Switch 3-Phase 240/139V Position			Voltage Selector Switch 3-Phase 480/277V Position		
	3Ø Line-Line	208V	220V	240V	416V	440V
1Ø Line-Neutral	120V	127V	139V	240V	254V	277V
Voltage Selector Switch Single-Phase 240/120V Position						
1Ø Line-Neutral/Line-Line	120V Line-Neutral	N/A	N/A	240V Line-Line	N/A	N/A

Voltage Selector Switch

Voltages are selected using the Voltage Selector switch (Figure 19) which is located above the output terminal panel's hard wire hook-up panel. This switch has been provided for ease of voltage selection.

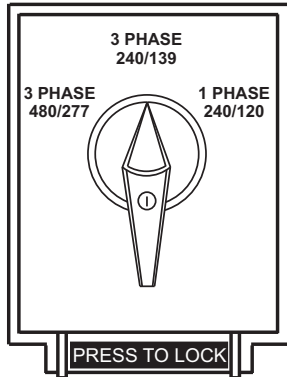

Figure 19. Voltage Selector Switch

CAUTION

NEVER change the position of the voltage selector switch while the engine is running. **ALWAYS** place the circuit breaker in the **OFF** position before selecting voltage.

Voltage Regulator

To obtain some of the voltages listed in Table 8 will require a fine voltage adjustment using the voltage regulator (Figure 20) located on the control panel.

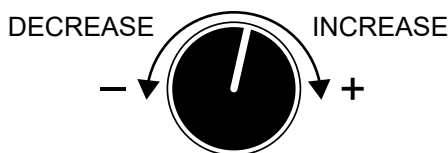

Figure 20. Voltage Regulator

Maximum Amps

Table 9 shows the **maximum** amps the generator can provide. **DO NOT** exceed the maximum amps as listed.

Table 9. Generator Maximum Amps	
Rated Voltage	Maximum Amps
1Ø 120 Volt	361 amps × 2 (Zigzag)
1Ø 240 Volt	361 amps (Zigzag)
3Ø 208 Volt	361 amps
3Ø 240 Volt	361 amps
3Ø 480 Volt	180 amps
Main Line Circuit Breaker Rating	400 amps

GFCI Receptacle Load Capability

The load capability of the GFCI receptacles is directly related to the voltage being supplied at either the output terminals or the three twist-lock auxiliary receptacles.

Table 10 and Table 11 show what amount of current is available at the GFCI receptacles when the output terminals and twist-lock receptacles are in use. Be careful that your load does not exceed the available current capability at the receptacle.

Table 10. 1Ø GFCI Receptacle Load Capacity	
kW in Use Twist Lock (CS6369)	Available Load Current (Amps)
1Ø 240/120V	GFCI Duplex 5-20R 120V
87.0	0
85.8	5 amps/receptacle
84.6	10 amps/receptacle
83.4	15 amps/receptacle
82.2	20 amps/receptacle

Table 11. 3Ø Generator Maximum Amps	
kVA in Use (UVWO Terminals)	Available Load Current (Amps)
3Ø 240/480V	GFCI Duplex 5-20R 120V
150	0 amps/receptacle
146	5 amps/receptacle
142	10 amps/receptacle
138	15 amps/receptacle
133	20 amps/receptacle

GAUGE READING

HOW TO READ THE AC AMMETER AND AC VOLTMETER GAUGES

The AC ammeter and AC voltmeter gauges are controlled by the AC ammeter and AC voltmeter change-over switches.

Both of these switches are located on the control panel and **DO NOT** affect the generator output. They are provided to help observe how much power is being produced at the UVWO terminal lugs.

Before taking a reading from either gauge, set the **Voltage Selector Switch** (Figure 21) to the position which produces the required voltage. For example, for 3Ø 240V, choose the center 3Ø 240/139V position on the voltage selector switch.

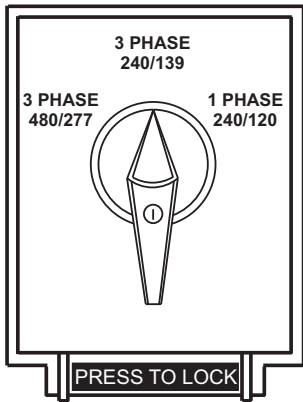

Figure 21. Voltage Selector Switch
240V/3Ø Position

AC Voltmeter Gauge Reading

Place the **AC Voltmeter Change-Over Switch** (Figure 22) in the W-U position and observe the phase-to-phase voltage reading between the W and U terminals as indicated on the **AC Voltmeter Gauge** (Figure 23).

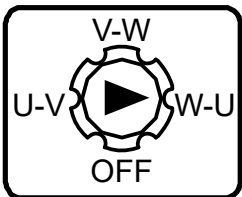

Figure 22. AC Voltmeter
Change-Over Switch

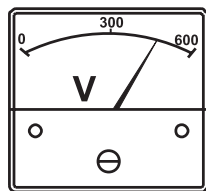

Figure 23. AC Voltmeter Gauge
(Volt Reading On W-U Lug)

AC Ammeter Gauge Reading

Place the **AC Ammeter Change-Over Switch** (Figure 24) in the U position and observe the current reading (load drain) on the U terminal as indicated on the **AC Ammeter Gauge** (Figure 25). This process can be repeated for terminals V and W.

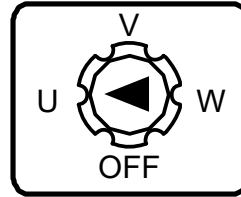

Figure 24. AC Ammeter
Change-Over Switch

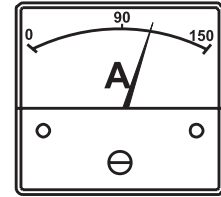

Figure 25. AC Ammeter
(Amp Reading On U Lug)

NOTICE

The **ammeter** gauge will only show a reading when the **output terminal lugs** are connected to a load and in use.

OUTPUT TERMINAL PANEL CONNECTIONS

UVWO TERMINAL OUTPUT VOLTAGES

Various output voltages can be obtained using the UVWO output terminal lugs. The voltages at the terminals are dependent on the position of the **Voltage Selector Switch** and the adjustment of the **Voltage Regulator**.

Remember the voltage selector switch determines the **range** of the output voltage. The voltage regulator (VR) allows the user to increase or decrease the selected voltage.

NOTICE

ALWAYS make sure that the connections to the UVWO terminals are **secure** and **tight**. The possibility exists of arcing that could cause a fire. Torque tie bolts to 554.9 lbf·in (62.7 N·m).

3Ø-240V UVWO Terminal Output Voltages

1. Place the voltage selector switch in the 3Ø 240/139V position as shown in Figure 26.

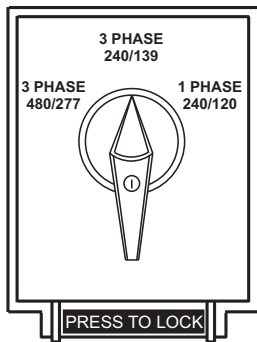

**Figure 26. Voltage Selector Switch
3Ø-240/139V Position**

2. Connect the load wires to the UVWO terminals as shown in Figure 27.

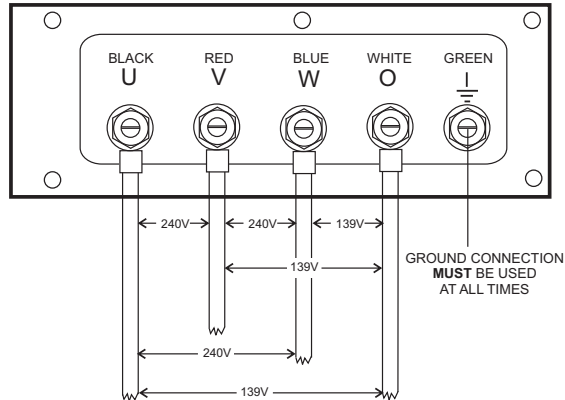

**Figure 27. UVWO Terminal Lugs
3Ø-240V/1Ø-139V Connections**

3. Turn the voltage regulator (Figure 28) clockwise to increase voltage output, turn counterclockwise to decrease voltage output. Use the voltage regulator whenever fine tuning of the output voltage is required.

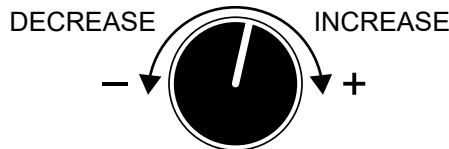
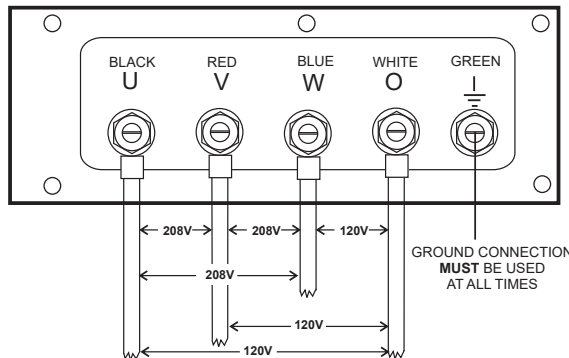

Figure 28. Voltage Regulator

3Ø-208V/1Ø-120V UVWO Terminal Output Voltages

1. Place the voltage selector switch in the 3Ø 240/139V position as shown in Figure 26.
2. Connect the load wires to the UVWO terminals as shown in Figure 29.



**Figure 29. UVWO Terminal Lugs
3Ø-208V/1Ø-120V Connections**

OUTPUT TERMINAL PANEL CONNECTIONS

NOTICE

To achieve a 3Ø 208V output the voltage selector switch must be in the 3Ø-240/139V position and the voltage regulator must be adjusted to 208V.

3Ø-480/277V UVWO Terminal Output Voltages

1. Place the voltage selector switch in the 3Ø 480/277V position as shown in Figure 30.

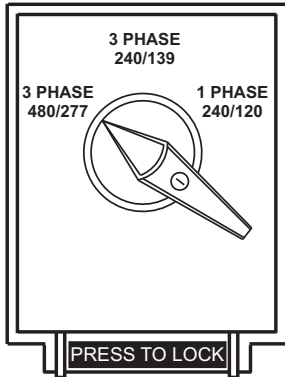

Figure 30. Voltage Selector Switch 3Ø-480/277V Position

2. Connect the load wires to the UVWO terminals as shown in Figure 31.

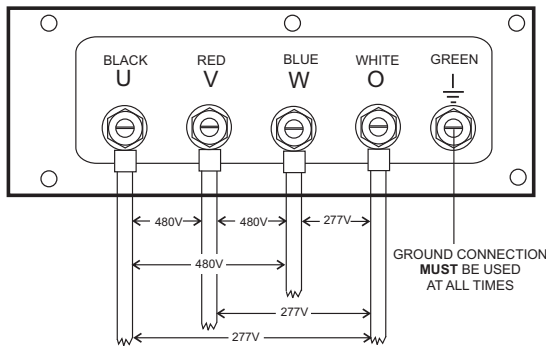

Figure 31. UVWO Terminal Lugs 3Ø-480V Connections

1Ø-240/120V UVWO Terminal Output Voltages

1. Place the voltage selector switch in the 1Ø 240/120V position as shown in Figure 32.

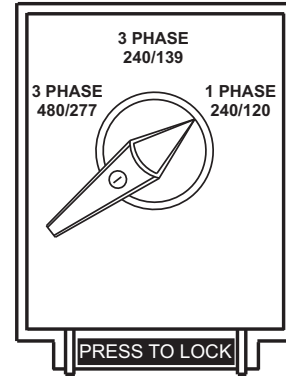

Figure 32. Voltage Selector Switch 1Ø-240/120V Position

2. Connect the load wires to the UVWO terminals as shown in Figure 33.

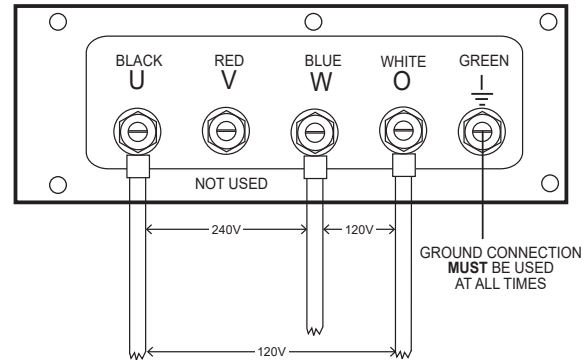

Figure 33. UVWO Terminal Lugs 1Ø-240/120V Connections

3. Turn the voltage regulator (Figure 28) clockwise to increase voltage output, turn counterclockwise to decrease voltage output. Use the voltage regulator whenever fine tuning of the output voltage is required.

FUEL CHECK

! DANGER



Fuel spillage on a **hot** engine can cause a **fire** or **explosion**. If fuel spillage occurs, wipe up the spilled fuel completely to prevent fire hazards. **NEVER** smoke around or near the generator.

NOTICE

ALWAYS check the DEF tank level when adding fuel.

Refilling The Fuel System

NOTICE

DO NOT refuel while the engine is running.

! CAUTION

ONLY properly trained personnel who have read and understand this section should refill the fuel tank system.

ALWAYS fill the fuel tank (Figure 37) with clean, fresh, #2 diesel fuel. **DO NOT** fill the fuel tank beyond its capacity.

Pay attention to the fuel tank capacity when replenishing fuel. The fuel tank cap must be closed tightly after filling. Handle fuel in a safety container. If the container does not have a spout, use a funnel. Wipe up any spilled fuel immediately.

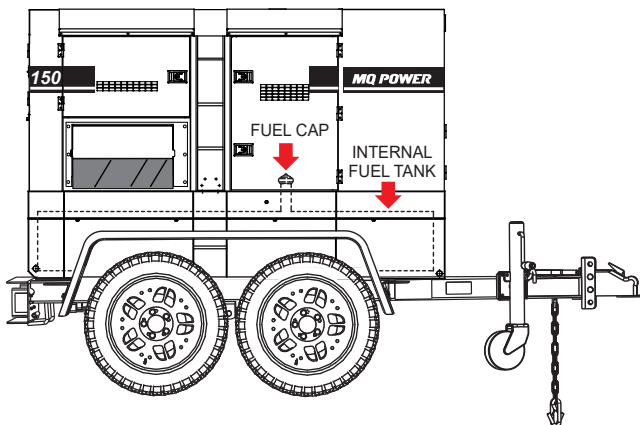

Figure 37. Fuel Tank

Refueling Procedure

! WARNING



Diesel fuel and its vapors are dangerous to your health and the surrounding environment. Avoid skin contact and/or inhaling fumes.

1. **Level Tanks** — Make sure fuel cells are level with the ground. Failure to do so will cause fuel to spill from the tank before reaching full capacity (Figure 38).

! CAUTION

ALWAYS place trailer on firm, level ground before refueling to prevent spilling and to maximize the amount of fuel that can be pumped into the tank.

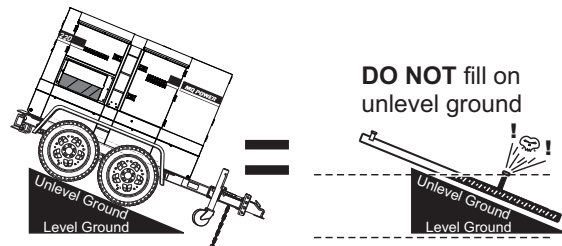

Figure 38. Only Fill On Level Ground

NOTICE

ONLY use **#2 diesel fuel** (ultra-low sulfur diesel fuel) when refueling.

2. Open the enclosure door, remove the fuel cap and fill the tank as shown in Figure 39.

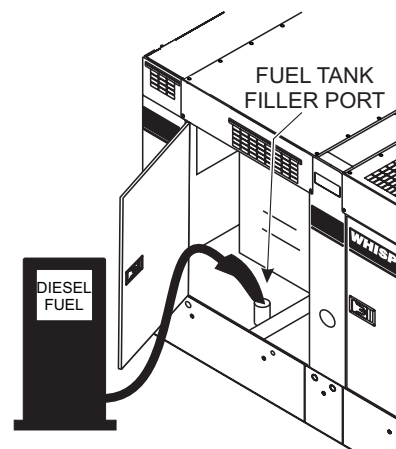

Figure 39. Fueling The Generator

- NEVER overfill the fuel tank** — It is important to read the fuel gauge when filling the trailer fuel tank. **DO NOT** wait for fuel to rise in the filler neck (Figure 40).

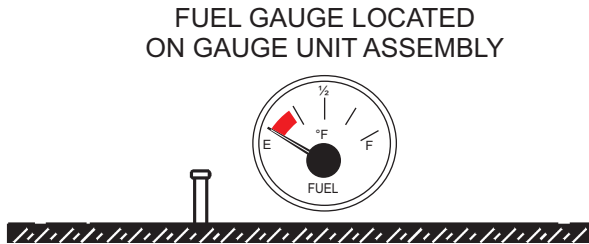

Figure 40. Full Fuel Tank

CAUTION

DO NOT OVERFILL the fuel system. Leave room for fuel expansion. Fuel expands when heated (Figure 41).

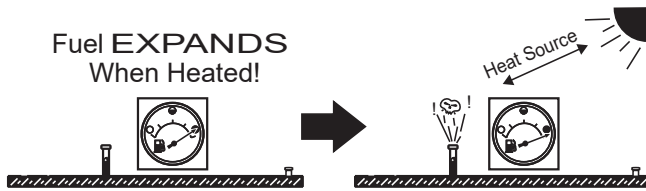

Figure 41. Fuel Expansion

DEF Refilling

NOTICE

ONLY fill the DEF tank with **diesel exhaust fluid**. Any other type of fluid may cause severe engine damage.

Diesel exhaust fluid is an aqueous solution made with 32.5% high-purity urea carbamide and 67.5% **deionized water**. DEF is used as a consumable in **selective catalytic reduction (SCR)** in order to lower NO_x concentration from diesel exhaust emissions.

- Make sure the engine is **OFF**.
- For DCA150SSJU4F2 generators, open the enclosure **rear door**, remove the filler cap from both DEF tanks and fill with DEF fluid (Figure 42).
- For DCA150SSJU4F3 generators, open the DEF **access door** (Figure 43), remove the filler cap and fill with DEF fluid.
- Before initial start-up, **completely fill** the DEF tank with DEF fluid. **DO NOT** overfill.

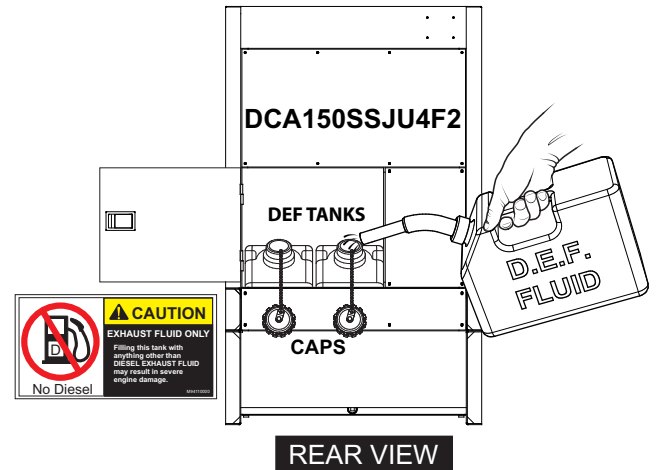

Figure 42. DEF Tank Filling (DCA150SSJU4F2)

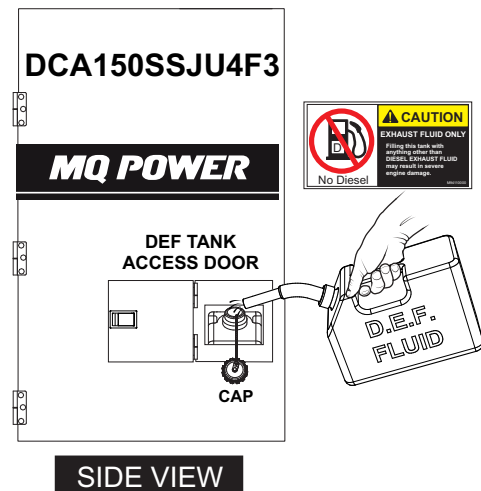

Figure 43. DEF Tank Filling (DCA150SSJU4F3)
DEF Refilling (Continuous Operation)

It is recommended to **shut down the engine** prior to refilling the DEF tank. However, in special applications where shutdown is not possible, it is recommended to **ONLY** refill the DEF tank when the fluid level has been consumed down to 50%.

The DEF level sending unit requires a gradual DEF level decrease during continuous operation to validate proper operation. Failure of this sensor to report the decrease could result in an engine shutdown. A engine service technician would be required to remedy the shutdown.

COOLANT (ANTIFREEZE/SUMMER COOLANT/WATER)

John Deere recommends Cool-Gard™ II antifreeze/summer coolant for use in their engines, which can be purchased in concentrate (and mixed with 50% demineralized water) or pre-diluted. See the **John Deere Engine Owner's Manual** for further details.

WARNING



If adding coolant/antifreeze mix to the radiator, **DO NOT** remove the radiator cap until the unit has completely cooled. The possibility of **hot!** coolant exists which can cause severe burns.

Day-to-day addition of coolant is done from the reserve tank. When adding coolant to the radiator, **DO NOT** remove the radiator cap until the unit has completely cooled. See Table 14 for engine, radiator, and reserve tank coolant capacities.

NOTICE

Normally, only the coolant level in the reserve tank needs to be checked. However, the radiator cap should be opened once a week to verify that coolant is visible (full) inside the radiator.

1. Verify that the coolant level in the coolant reserve tank is between the **FULL** and **LOW** markings as shown in Figure 44.

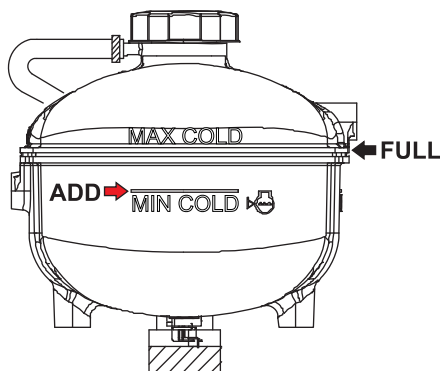

Figure 44. Coolant Reserve Tank

Table 13. Coolant Capacity	
Engine and Radiator	12.9 gal (48.7 liters)
Reserve Tank	See markings

Operation In Freezing Weather

When operating in freezing weather, be certain the proper amount of antifreeze (Table 14) has been added.

Table 14. Coolant Capacity		
Climate	Outside Temperature	Longlife Coolant Concentration
Warm	10°F (-12°C) or Above	30%
Cold	-22°F (30°C) or Above	50%

NOTICE

When the antifreeze is mixed with water, the antifreeze mixing ratio **must be** less than 50%.

Cleaning The Radiator

The engine may overheat if the radiator fins become overloaded with dust or debris. Periodically clean the radiator fins with compressed air. Cleaning inside the machine is dangerous, so clean only with the engine turned off and the **negative** battery terminal disconnected.

ENGINE AIR CLEANER

Periodic cleaning/replacement is necessary. Inspect the air cleaner in accordance with the **John Deere Engine Owner's Manual**.

FAN BELT TENSION

The engine fan belt is automatically tensioned and does not require adjustment.

CAUTION



NEVER place hands near the belts or fan while the generator set is running.

BATTERY

This unit is of negative ground. **DO NOT** connect in reverse. Always maintain battery fluid level between the specified marks. Battery life will be shortened if the fluid level is not properly maintained. Add only distilled water when replenishment is necessary.

DO NOT overfill. Check to see whether the battery cables are loose. Poor contact may result in poor starting or malfunctions. **ALWAYS** keep the terminals firmly tightened. Coat the terminals with an approved battery terminal treatment compound. Replace the battery with only the recommended type battery. The battery type used in this generator is BCI Group 27.

The battery is sufficiently charged if the specific gravity of the battery fluid is 1.28 (at 68°F). If the specific gravity should fall to 1.245 or lower, it indicates that the battery is dead and needs to be recharged or replaced.

Before charging the battery with an external electric source, be sure to disconnect the battery cables.

Battery Cable Installation

ALWAYS be sure the battery cables (Figure 45) are properly connected to the battery terminals as shown below. The **red cable** is connected to the positive terminal of the battery, and the **black cable** is connected to the negative terminal of the battery.

CAUTION

ALWAYS disconnect the negative terminal **FIRST** and reconnect the negative terminal **LAST**.

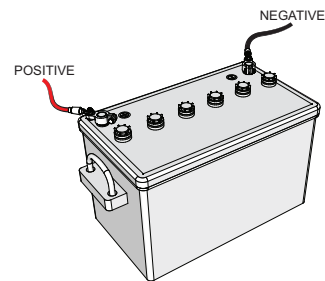

Figure 45. Battery Connections

When connecting the battery do the following:

1. **NEVER** connect the battery cables to the battery terminals when the **Auto Start/Stop switch** is in either the **AUTO** or **MANUAL** position. **ALWAYS** make sure that this switch is in the **OFF/RESET** position when connecting the battery.
2. Place a small amount of battery terminal treatment compound around both battery terminals. This will ensure a good connection and will help prevent corrosion around the battery terminals.

NOTICE

If the battery cable is connected incorrectly, electrical damage to the generator will occur. Pay close attention to the polarity of the battery when connecting the battery.

CAUTION

Inadequate battery connections may cause poor starting of the generator, and create other malfunctions.

ALTERNATOR

The polarity of the alternator is negative grounding type. When an inverted circuit connection takes place, the circuit will be in short circuit instantaneously, resulting in alternator failure.

DO NOT put water directly on the alternator. Entry of water into the alternator can cause corrosion and damage the alternator.

WIRING

Inspect the entire generator for bad or worn electrical wiring or connections. If any wiring or connections are exposed (insulation missing) replace wiring immediately.

PIPING AND HOSE CONNECTIONS

Inspect all piping, oil hose, and fuel hose connections for wear and tightness. Tighten all hose clamps and check hoses for leaks.

If any fuel or oil hose lines are defective, replace them immediately.

COLD WEATHER ENGINE STARTING FLUID (ETHER) SYSTEM

This unit is equipped with an automatically controlled Engine Starting Fluid System (KBi's DIESELMATIC NVT) that assists engine starting during **low** ambient temperature operation.

The system is designed to spray a controlled amount of starting fluid into the air intake system of the engine during and immediately after the engine cranks. The fluid cylinder is located on the unit's right-side center frame.

WARNING

The engine starting fluid used in the system is extremely flammable and toxic. It can be harmful and fatal if swallowed. Avoid contact with skin or breathing fumes.

DO NOT smoke when installing, removing, maintaining, testing or troubleshooting the system. Make sure you are in a well-ventilated area away from heat, open flames or sparks.

In low-ambient temperature conditions, if the engine does not start within a normal period of cranking, the starting fluid cylinder may be empty and need to be replaced. For more information about the system, refer to the provided KBi DIESELMATIC NVT Instruction Manual.

GENERATOR START-UP PROCEDURE (MANUAL)

BEFORE STARTING

CAUTION

The engine's exhaust contains harmful emissions. **ALWAYS** have adequate ventilation when operating. Direct exhaust away from nearby personnel.

WARNING

NEVER manually start the engine with the **main, GFCI or auxiliary** circuit breakers in the **ON** (closed) position.

1. Place the **main, auxiliary, and GFCI** circuit breakers (Figure 46) in the **OFF** position prior to starting the engine.

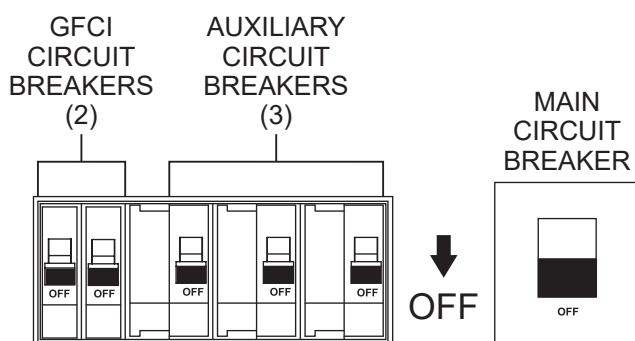

Figure 46. Main, Auxiliary, And GFCI Circuit Breakers (OFF)

2. Make sure the voltage selector switch has been configured for the desired output voltage.
3. Connect the load to the **receptacles, output terminal lugs**, or optional **cam-loks** as shown in Figure 16. These load connection points can be found on the output terminal panel and the output terminal panel's hard wire hookup panel.

NOTICE

ALWAYS make sure that the connections to the UVWO terminals are **secure** and **tight**. The possibility exists of arcing that could cause a fire. Torque tie bolts to 554.9 lbf·in (62.7 N·m).

4. Close all engine enclosure doors (Figure 47).

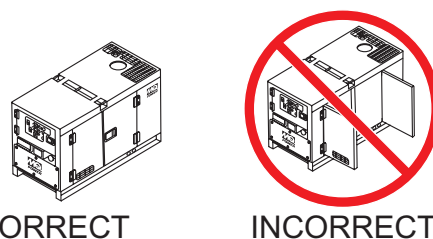

Figure 47. Engine Enclosure Doors

STARTING (MANUAL)

1. Place the **Engine Speed** switch in the **LOW** position (Figure 48).



Figure 48. Engine Speed Switch (Low Position)

2. To start the engine, place the **Auto Start/Stop** switch in the **MANUAL** position (Figure 49).



Figure 49. Auto Start/Stop Switch (Manual Position)

NOTICE

If the engine fails to start within three attempts, the Shutdown lamp will illuminate and the Auto Start/Stop switch must be placed in the Off/Reset position before the next attempt.

NOTICE

The engine will pre-heat automatically in cold weather conditions. "Glow Plug Hold" message will be displayed and the engine will start automatically after pre-heating.

3. Once the engine starts, let the engine run for 1–2 minutes to warm up. For operation in below-freezing weather temperatures, this warmup period must be extended to 5–7 minutes. During the warmup period, check for any abnormal noise, vibration, or fluid leakage. Check the gauges on the control panel. If any abnormalities exist, shut down the engine and correct the problem.

GENERATOR START-UP PROCEDURE (MANUAL)

4. After the warmup process has completed, place the **Engine Speed switch** in the **HIGH** (up) position. The engine speed will increase to 1,800 rpm and the unit is now ready for operation.

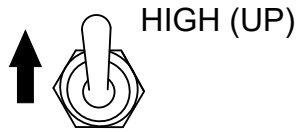

Figure 50. Engine Speed Switch (High Position)

5. The generator's **frequency meter** (Figure 51) should be displaying the 60-cycle output frequency in **HERTZ**.

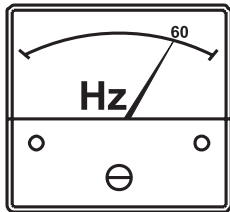

Figure 51. Frequency Meter

6. The generator's **AC voltmeter** (Figure 52) will display the generator's output in **VOLTS**.

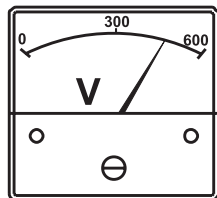

Figure 52. Voltmeter

7. If the voltage is not within the specified tolerance, use the **voltage regulator** (Figure 53) to increase or decrease the desired voltage.

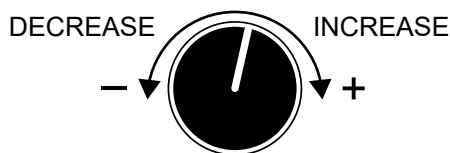

Figure 53. Voltage Regulator

8. The **ammeter** (Figure 54) will indicate **zero amps** with no load applied. When a load is applied, the ammeter will indicate the amount of current that the load is drawing from the generator.

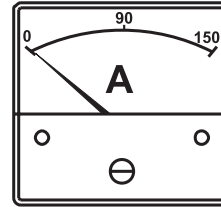

Figure 54. Ammeter (No Load)

9. The **engine oil pressure gauge** (Figure 55A) will indicate the oil pressure of the engine. Under normal operating conditions the oil pressure should be approximately 46 psi (317 kPa). When starting the generator the oil pressure may read a little higher, but after the engine warms up the oil pressure should return to the correct pressure range.

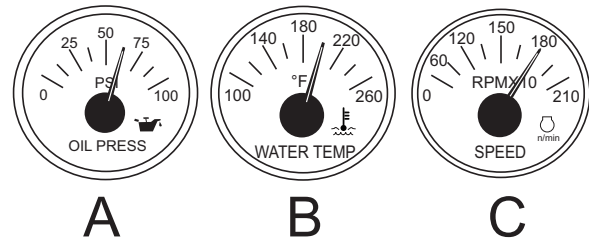

Figure 55. Engine Gauges

10. The **coolant temperature gauge** (Figure 55B) will indicate the coolant temperature. Under normal operating conditions the coolant temperature should be between 185°F and 207°F (85°–97°C).

11. The **tachometer** (Figure 55C) will indicate the speed of the engine when the generator is operating. Under normal operating conditions, this gauge should indicate 1,200 rpm when the Engine Speed switch is the LOW position, and 1,800 rpm when the Engine Speed switch is in the HIGH position.

GENERATOR START-UP PROCEDURE (MANUAL)

12. Place the **main, auxiliary, and GFCI** circuit breakers in the **ON** position (Figure 56).

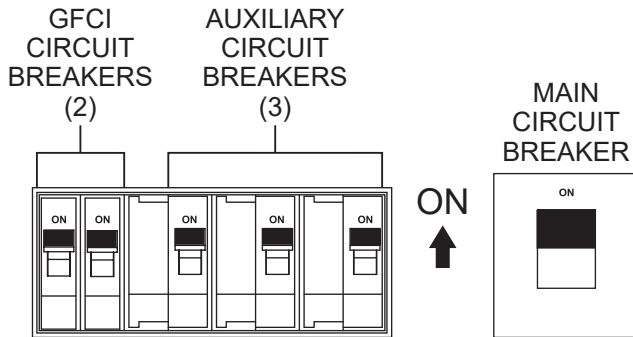

Figure 56. Main, Auxiliary, And GFCI Circuit Breakers (ON)

13. Observe the generator's ammeter (Figure 57) and verify it reads the anticipated amount of current with respect to the load. The ammeter will only display a current reading if a load is in use.

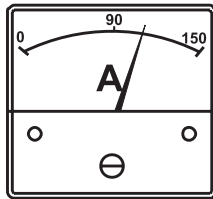

Figure 57. Ammeter (Load)

14. Verify that the **generator load gauge** (Figure 58) reads the anticipated percentage of load. It is recommended the load be above the red area (20%) for maintaining sufficient exhaust temperature.

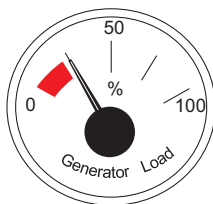

Figure 58. Generator Load Gauge

15. The generator will run until manually stopped or an abnormal condition occurs.

GENERATOR START-UP PROCEDURE (AUTO)

STARTING (AUTO MODE)

DANGER



Before connecting this generator to any building's electrical system, a **licensed electrician** must install an **isolation (transfer) switch**. Serious damage to the building's electrical system may occur without this transfer switch.

NOTICE

When connecting the generator to an isolation (transfer) switch, **ALWAYS** have power applied to the generator's internal battery charger. This will ensure that the engine will not fail due to a dead battery.

NOTICE

When the generator is set to **AUTO** mode, the generator will **automatically start** in the event of commercial power falling below a prescribed level by means of a contact closure that is generated automatically by a transfer switch.

WARNING

When operating the generator in **AUTO** mode, remember that the generator can start up at any time without warning. **NEVER** attempt to perform any maintenance while the generator is in Auto mode.

CAUTION

The Engine Speed switch **must** be set to the **High position** when running in **Auto mode**. Failing to set the switch in the proper position can result in damage to the generator when it turns on.

NOTICE

When the **Auto Start/Stop switch** is placed in the **AUTO** position, the engine glow plugs will be warmed and the engine will start automatically.

NOTICE

The battery charger option can only be operated when the generator is in Manual Start mode.

1. Perform steps 1–4 under **Before Starting** in the **Generator Start-Up Procedure (Manual)** section.
2. Place the **Engine Speed switch** in the **HIGH** position (Figure 59).



Figure 59. Engine Speed Switch (High Position)

3. Place the **Auto Start/Stop switch** (Figure 60) in the **AUTO** position.



Figure 60. Auto Start/Stop Switch (Auto Position)

4. Once the start signal is received (the remote-start contacts are closed), the pre-heating process will begin. When the pre-heating process has completed, the engine will start automatically and accelerate to rated speed. When the remote-start contacts are opened, the engine will stop.
5. If the engine fails to start, perform the manual starting procedure.

NOTICE

If the unit has **PowerBalance®** installed, once the main breaker is closed, the PowerBalance® should activate after 1 minute if the load is below 30% of the rated load.

If at any time the load spikes to 90% or more, the PowerBalance® will immediately drop out and wait 5 minutes to re-evaluate the load.

GENERATOR SHUTDOWN PROCEDURE

NORMAL SHUTDOWN PROCEDURE

WARNING

NEVER stop the engine suddenly except in an emergency.

To shut down the generator, use the following procedure:

1. Place the load's ON/OFF switch in the **OFF** position.
2. Place the **main, auxiliary, and GFCI** circuit breakers (Figure 61) in the **OFF** position.

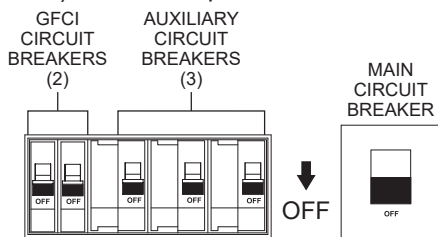

Figure 61. Main, Auxiliary, And GFCI Circuit Breakers (OFF)

3. Place the **Engine Speed** switch in the **LOW** position (Figure 62).



Figure 62. Engine Speed Switch (Low Position)

4. Let the engine cool by running it at low speed for 3–5 minutes with no load applied.
5. Place the **Auto Start/Stop** switch (Figure 63) in the **OFF/RESET** position.

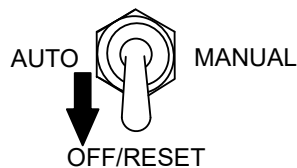

Figure 63. Auto Start/Stop Switch (Off/Reset Position)

NOTICE

DO NOT disconnect the battery cables immediately after the engine stops. Wait for at least 30 seconds before disconnecting the battery cables.

6. Allow adequate time for cooling, then inspect the entire generator for any damage or loosening of components that may have occurred during operation.

EMERGENCY SHUTDOWN PROCEDURE

NOTICE

The **Emergency Stop** switch should only be used to stop the engine in case of an emergency or to lock out operation during service. The Emergency Stop switch should **NEVER** be used for routine stopping of the engine.

1. To stop the engine in the event of an emergency, press the **Emergency Stop** switch (Figure 64).

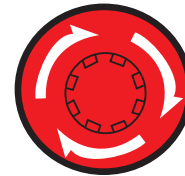

Figure 64. Emergency Stop Switch

2. Place the **main, auxiliary, and GFCI** circuit breakers in the **OFF** position as shown in Figure 61.
3. The Emergency Stop switch is a push-locked type switch. The switch contact can only be released by rotating the button in the clockwise direction. The engine cannot be restarted until the contact is released (closed).

AUTOMATIC SHUTDOWN SYSTEM

This unit is equipped with safety devices that will automatically shut down the engine when a fault occurs. The Shutdown lamp on the controller will illuminate and diagnostic trouble codes will be displayed to signify the reason for the shutdown. Refer to the **Troubleshooting** section of this manual for more information.

NOTICE

Before inspecting the generator after an automatic shutdown, place the Auto Start/Stop switch in the **OFF/RESET** position, and place all circuit breakers in the **OFF** position. Allow adequate time for cooling before troubleshooting. When all faults have been cleared, restart the engine according to the **Generator Startup Procedure** section of this manual.

MAINTENANCE

Table 15. Inspection/Maintenance		10 Hours or Daily	250 Hours	Every 500 Hours or 12 Months	Every 3,000 Hours or 36 Months	Other
Engine	Check Engine Oil and Coolant Levels	X				
	Check Fuel Filter/Water Separator Bowl	X				
	Check Air Cleaner/Element	X				
	Clean or Replace Air Cleaner/Element		X			
	Check for Leaks/Hoses/Clamps	X				
	Check for Loosening of Parts	X				
	Change Engine Oil and Oil Filter *1		X			
	Clean Unit, Inside and Outside		X			
	Replace Fuel Filter Elements			X		
	Check Engine Mounts			X		
	Service Battery			X		
	Check Air Intake Hoses			X		
	Check Fan Belt Condition			X		
	Check Automatic Belt Tensioner			X		
	Check Electrical Ground Connection			X		
	Clean Radiator, Check Cooling System			X		
	Coolant Solution Analysis, Add SCAs as Required			X		
	Pressure Test Cooling System			X		
	Check Engine Speed			X		
	Test Thermostats				X	
	Check and Adjust Engine Valve Clearance					1,000 hours
	Test Glow Plugs				X	
	Replace DEF Filter In (Supply Module)					4,500 hours
	Replace DOC Catalyst*5					As Required
	Check SCR System*2					4,500 hours
Inspect Dosing Module (SCR System)					4,500 hours	
Flush and Refill Cooling System*3					1 year or 2,000 hours	
Clean Inside of Fuel Tank					1,000 hours	
Clean DEF Tank					As Required	
Replace Air Cleaner Elements *4					As Required	
Generator	Measure Insulation Resistance Over 3M Ohms		X			
	Check Rotor Rear Support Bearing			X		

*1 During initial operation of a new engine, change oil and filter between a minimum of 100 hours and a maximum of 500 hours. Service interval depends on type of oil.

*2 Perform inspection and maintenance of Urea SCR system every 4,500 hours. The system does not need to be replaced/exchanged if no problem is found. Do not make any modification, changes or remove the emission control system and related parts. Please contact your nearest dealer or Multiquip Service Dept. for SCR maintenance.

*3 If John Deere COOL-GARD™ II is used, the flushing intervals may be extended. See "Testing Diesel Coolant" in the engine manual.

*4 Replace the primary air filter element when the restriction indicator shows a vacuum of 25 in. (625 mm) H₂O.

*5 Service should be performed as indicated by diagnostic gauge. Contact Multiquip Service Department for DOC replacement.

GENERAL INSPECTION

Prior to each use, the generator should be cleaned and inspected for deficiencies. Check for loose, missing or damaged nuts, bolts or other fasteners. Also check for fuel, oil, and coolant leaks. Use Table 15 as a general maintenance guideline. For more detailed engine maintenance instructions, refer to the engine owner's manual.

ENGINE AIR CLEANER

This John Deere diesel engine is equipped with a replaceable, high-density, paper air cleaner element (Figure 65). The air cleaner is also equipped with an inner (secondary) element that is used as a backup filter should the primary element become damaged. Check the air cleaner daily or before starting the engine. Replace the air cleaner as needed.

NOTICE

If the engine is operating in very dusty or dry grass conditions, a clogged air cleaner will result. This can lead to a loss of power, excessive carbon buildup in the combustion chamber, and high fuel consumption. Change the air cleaner more frequently if these conditions exist.

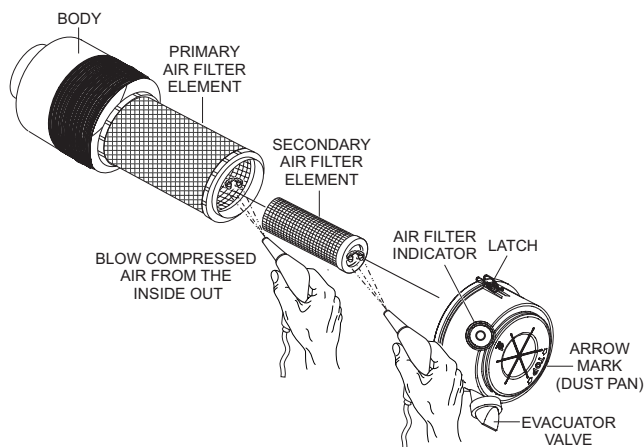

Figure 65. Engine Air Cleaner

Primary And Secondary Air Cleaner Elements

Every 250 hours: Remove the air cleaner elements and clean them with a light spray of compressed air.

CAUTION



Wear protective equipment such as approved safety glasses or face shields and dust masks or respirators when cleaning air filters with compressed air.

1. Release the **latches** that secure the **air cleaner cover** to the **air cleaner body** (Figure 65).
2. Remove the air cleaner cover (Figure 65) and set it aside.
3. Remove both the primary and secondary **air cleaner elements** (Figure 65).
4. Check for and correct heavy buildup of dirt and debris along with loose or damaged components.

NOTICE

Operating the engine with loose or damaged air cleaner components could allow unfiltered air into the engine causing premature wear and failure.

5. To clean the **primary element** (paper air filter) as shown in Figure 65, tap the filter element several times on a hard surface to remove dirt, or blow compressed air, not to exceed 30 psi (207 kPa, 2.1 kgf/cm²), through the filter element from the inside out.
6. Clean the **secondary element** (paper air filter) as described in step 5.
7. Replace both elements if they are damaged or excessively dirty.
8. Clean the inside of the air cleaner body (Figure 65).
9. Reinstall the primary and secondary air filter elements back into the air cleaner body.
10. Reinstall the air cleaner cover and secure with the latches.

NOTICE

DO NOT run the engine with the air cleaner removed or without an element.

Air Cleaner Restriction Indicator

The air cleaner is equipped with a **restriction indicator** (Figure 66). As the air cleaner element becomes clogged, air intake restriction increases and the indicator signal shows **RED**, indicating that the element needs to be replaced. After replacing the air cleaner element, press the restriction indicator button to reset the indicator.

PUSH BUTTON TO RESET

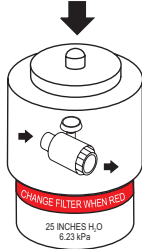

Figure 66. Air Cleaner Restriction Indicator

NOTICE

The air cleaner element should not be changed until the indicator displays **RED**. Dispose of the old element. It cannot be cleaned or reused.

ENGINE FUEL FILTER

Inspect the engine fuel filter daily. If the fuel filter has collected a significant amount of water and sediment at the bottom of the cup, it should be drained off immediately.

Draining The Fuel Filter

1. Loosen the air bleeder plug (Figure 67) on the fuel filter head.
2. To discharge the fuel inside the fuel filter cartridge, **OPEN** the drain valve on the fuel filter by turning the knob **counterclockwise** (Figure 67A) approximately 3-1/2 turns until the valve drops down 1 inch (25.4 mm) and draining occurs (Figure 67B).

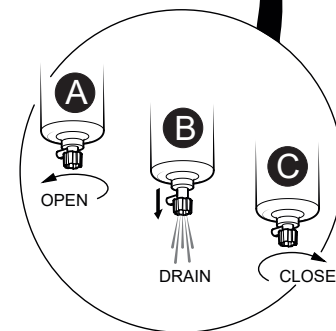
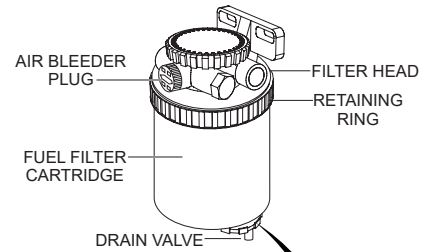

Figure 67. Draining The Fuel Filter

3. Let the residue or foreign substances inside the cartridge flow into a suitable container.
4. At completion of draining, **CLOSE** the drain valve (Figure 67C).

Fuel Filter Cartridge Replacement

1. Use a filter wrench to remove the fuel filter cup (Figure 68) from the fuel filter head.

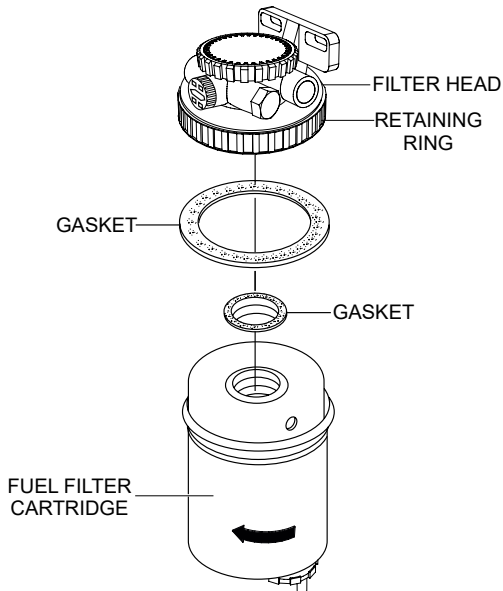

Figure 68. Fuel Filter Cartridge Replacement

2. Wipe the inside of the filter head with a clean cloth to remove any foreign matter or debris that may have accumulated.
3. Replace both gaskets. Coat each gasket with a small amount of clean 15W-40 engine oil.
4. Install the new fuel filter cartridge first by hand until it makes contact with the fuel filter body surface.
5. Tighten the fuel filter cartridge securely. **DO NOT** overtighten.

6. Remove the air from the fuel system. Reference the John Deere Owner's Manual, "Bleeding the Fuel System."

Fuel Water Separator Sediment Bowl

1. Remove the sediment bowl from the fuel water separator cartridge as shown in Figure 69.

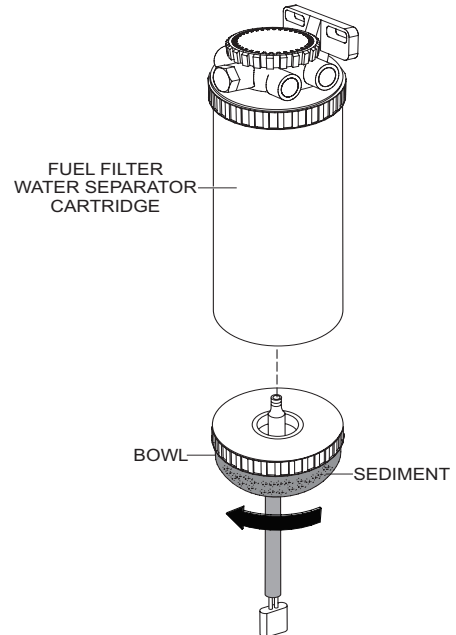

Figure 69. Sediment Bowl

2. Let the residue or foreign substances inside the sediment bowl flow into a suitable container.
3. Wipe the inside of the sediment bowl with a clean cloth to remove any foreign matter or debris that may have accumulated.
4. Reinstall the sediment bowl back onto the fuel water separator cartridge.
5. Tighten securely. **DO NOT** overtighten.

Fuel Water Separator Replacement

1. Use a filter wrench to remove the fuel water separator cartridge (Figure 70) from the cartridge head.

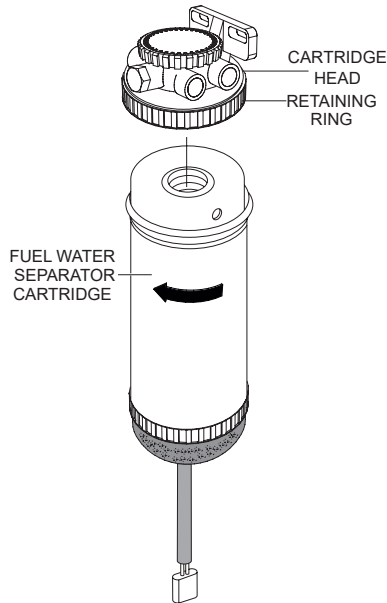

Figure 70. Fuel Water Separator

2. Wipe the inside of the cartridge head with a clean cloth to remove any foreign matter or debris that may have accumulated.
3. Install the new fuel water separator cartridge first by hand until it makes contact with the cartridge head surface.
4. Tighten the fuel water cartridge securely. **DO NOT** overtighten.

Removing Water From The Fuel Tank

After prolonged use, water and other impurities accumulate in the bottom of the tank. Occasionally inspect the fuel tank for water contamination and drain the contents if required.

During cold weather, the more empty volume inside the tank, the easier it is for water to condense. This can be reduced by keeping the tank full with diesel fuel.

Cleaning Inside The Fuel Tank

If necessary, drain the fuel inside the fuel tank completely. Using a spray washer (Figure 71) wash out any deposits or debris that have accumulated inside the fuel tank.

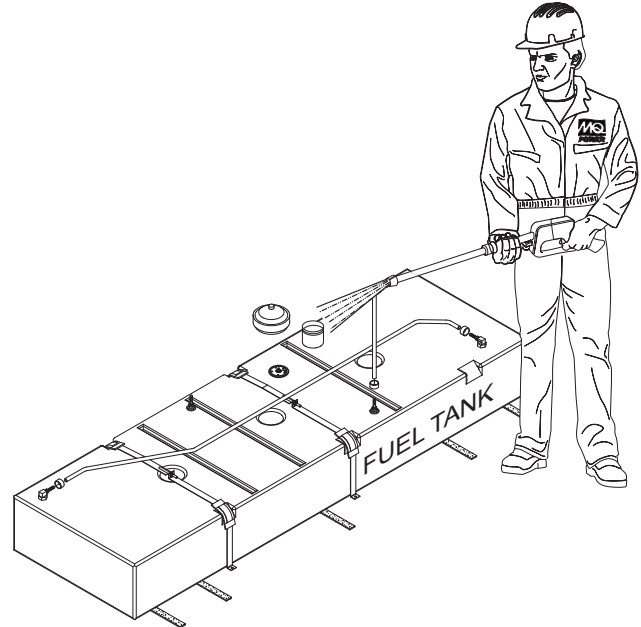

Figure 71. Cleaning The Fuel Tank

FUEL TANK INSPECTION

In addition to cleaning the fuel tank, the following components should be inspected for wear:

- **Rubber Suspension** — Look for signs of wear or deformity due to contact with oil. Replace the rubber suspension if necessary.
- **Fuel Hoses** — Inspect nylon and rubber hoses for signs of wear, deterioration or hardening.
- **Fuel Tank Lining** — Inspect the fuel tank lining for signs of excessive amounts of oil or other foreign matter.

DRAINING THE ENGINE OIL

1. Run the engine until the engine coolant reaches a temperature of 140°F (60°C).
2. Turn the engine off.
3. Remove the oil dipstick from its holder.
4. Remove the **oil drain cap** (Figure 72).
5. Place the **oil drain valve** in the **OPEN** position and allow the oil to drain into a suitable container.

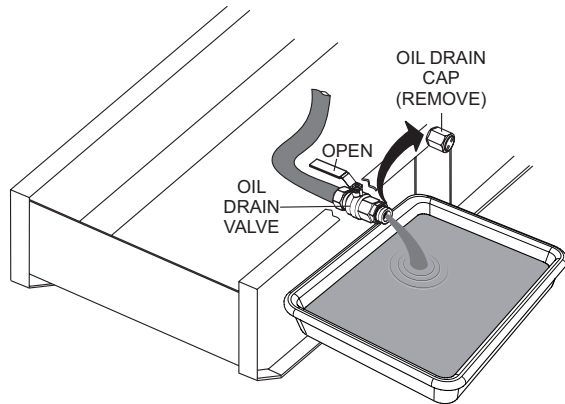

Figure 72. Draining The Engine Oil

6. After the engine oil has been completely drained, reinstall the oil drain cap and tighten securely.
7. Place the **oil drain valve** in the **CLOSED** position.

ENGINE OIL FILTER REPLACEMENT

1. Using an oil filter wrench (Figure 73), remove the engine oil filter.

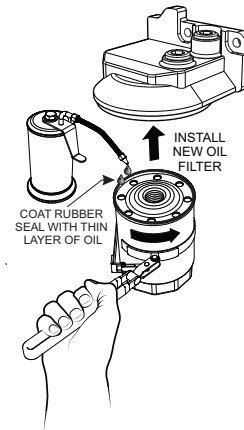
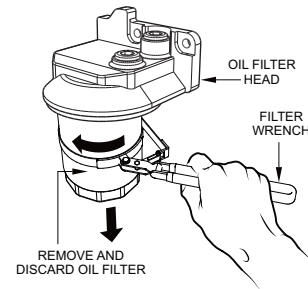

Figure 73. Engine Oil Filter Removal

2. Clean the area around the lubricating oil filter head.
3. Coat the rubber seal (gasket) surface of the new oil filter (Figure 73) with clean 15W-40 engine oil.
4. Install the new oil filter first by hand until it makes contact with the filter head surface. Tighten it another 3/4 turn using the filter wrench.
5. Fill the engine crankcase with high-quality detergent oil classified "For Service CI-4." Fill to the upper limit of the dipstick. **DO NOT** overfill. Reference Table 2 for engine crankcase oil capacity.
6. Run the engine for several minutes. Watch for oil leakage. Shut the engine down and allow it to sit for several minutes. Top off the oil to the upper limit on the dipstick.

DRAINING THE ENGINE COOLANT

! WARNING



DO NOT remove the pressure cap from the radiator when the engine is hot! Wait until the coolant temperature is below 120°F (50°C) before removing the pressure cap.

Heated coolant spray or steam can cause severe scalding and personal injury.

1. Remove the radiator pressure cap (Figure 74) only if the coolant temperature is below 120°F (50°C).

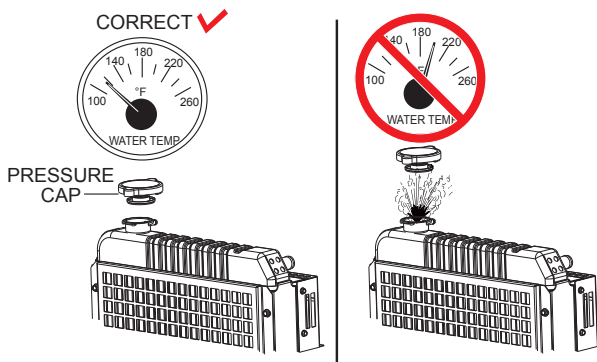

Figure 74. Radiator Pressure Cap Removal

2. Open the cabinet door and place the **coolant drain valve** in the **OPEN** position (Figure 75) and allow the coolant to drain into a suitable container.

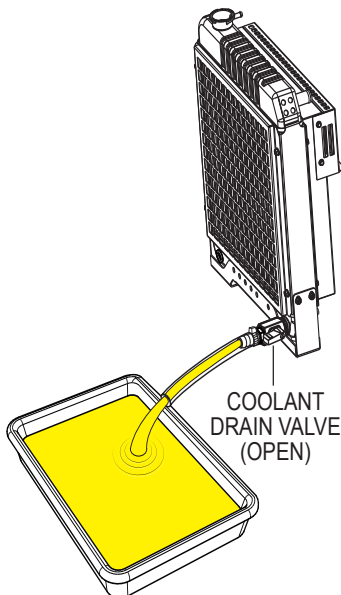

Figure 75. Draining The Engine Coolant

FLUSHING OUT THE RADIATOR AND REPLACING COOLANT

! WARNING



Allow the engine to **cool** before flushing out the radiator. Flushing the radiator while hot could cause serious burns from water or steam.

- Open both cocks located at the crankcase side and at the lower part of the radiator and drain the coolant. Open the radiator cap while draining. Remove the overflow tank and drain.
- Check hoses for softening and kinks. Check clamps for signs of leakage.
- Tighten both cocks and replace the overflow tank.
- Replace with coolant as recommended by the engine manufacturer.
- Close the radiator cap tightly.
- Flush the radiator by running clean tap water through the radiator until signs of rust and dirt are removed. **DO NOT** clean the radiator core with any objects, such as a screwdriver.

RADIATOR CLEANING

The radiator (Figure 76) should be sprayed clean with a high-pressure washer when excessive amounts of dirt and debris have accumulated on the cooling fins or tube. When using a high-pressure washer, stand at least 5 feet (1.5 meters) away from the radiator to prevent damage to the fins and tube.

NOTICE

It may be necessary to remove additional generator components in order to access the radiator for cleaning.

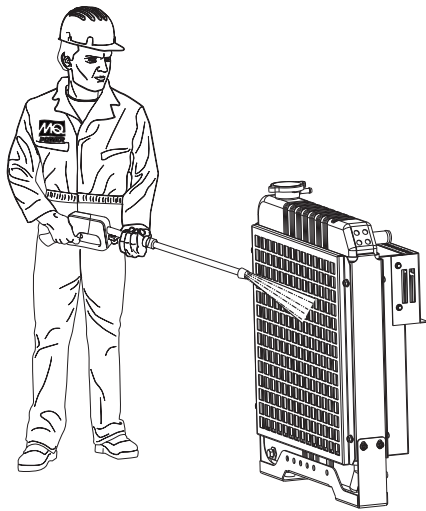

Figure 76. Cleaning The Radiator

DRIVE BELT (DAILY)

Drive Belt Tension

A slack drive belt may contribute to overheating, or to insufficient charging of the battery. Adjust the drive belt in accordance with the John Deere Engine Owner's manual.

Drive Belt Inspection

Inspect the drive belt (Figure 77) for damage and wear. Horizontal cracks (across the belt) are acceptable. Vertical (direction of belt ribs) cracks that intersect with horizontal cracks are not acceptable.

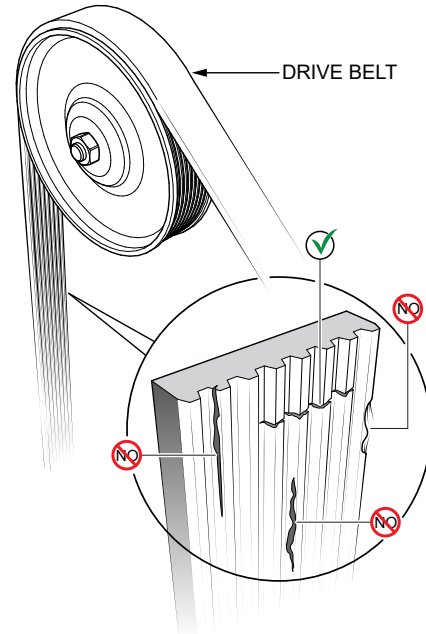

Figure 77. Drive Belt Inspection

Also, examine the belt and determine if it is **oil soaked** or **glazed** (a hard shiny appearance on the sides of the belt). Either of these two conditions can cause the belt to run hot, which can weaken it and increase the danger of it breaking.

If the drive belt exhibits any of the above wear conditions, replace the drive belt immediately.

TESTING THE GFCI RECEPTACLE

NOTICE

The GFCI receptacle is designed to interrupt power when a ground fault exists to prevent injuries and shock hazards. **DO NOT** use the GFCI receptacle if the test below fails. Consult a qualified electrician for repair or replacement of the GFCI receptacle. Test the GFCI receptacle **at least once a month**.

1. Start the generator as outlined in the start-up procedure in this manual.
2. Place a GFCI circuit breaker (Figure 78) in the **ON** position.

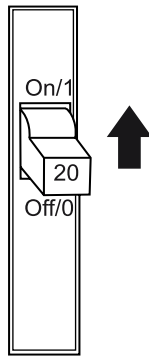

Figure 78. GFCI Circuit Breaker

3. Verify that the status LED on the corresponding GFCI receptacle (Figure 79) is **ON (GREEN)**.

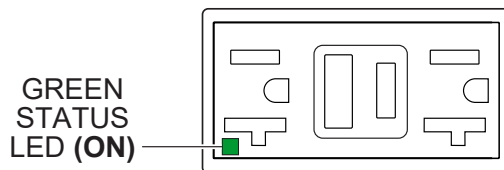

Figure 79. GFCI Receptacle (ON)

4. Press the **TEST** button (Figure 80) on the GFCI receptacle and verify that the status LED turns **OFF**.

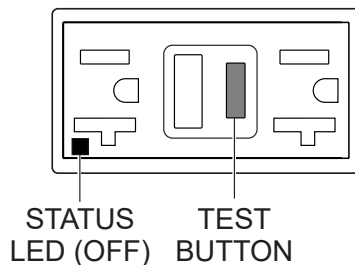

Figure 80. GFCI Receptacle (OFF)

5. Press the **RESET** button (Figure 81) to restore power to the GFCI receptacle and verify that the status LED is **ON (GREEN)**.

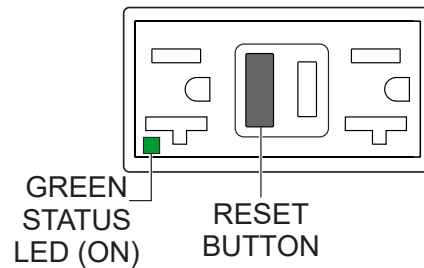

Figure 81. GFCI Receptacle (ON/Restore)

6. If the status LED (Figure 82) is **flashing (RED)**, **DO NOT** use the GFCI receptacle and replace it immediately.

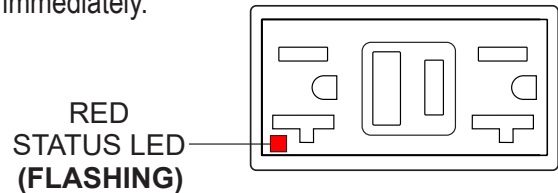

Figure 82. GFCI Receptacle (RED Flashing LED)

7. Repeat the above procedure for the other GFCI receptacle.

GENERATOR STORAGE

For long-term storage of the generator the following is recommended:

- Drain the fuel tank completely. Treat with a fuel stabilizer if necessary.
- Completely drain the oil from the crankcase and refill if necessary with fresh oil.
- Clean the entire generator, internal and external.
- Cover the generating set and store in a clean, dry place.
- Disconnect the battery.
- Make sure engine coolant is at the proper level.
- If the generator is mounted on a trailer, jack the trailer up and place it on blocks so the tires do not touch the ground or block and completely remove the tires.

ENGINE BLOCK HEATER AND OPTIONAL INTERNAL BATTERY CHARGER 120 VAC INPUT RECEPTACLES

This generator comes equipped with an **engine block heater** and an **internal battery charger** is available as an option. They are provided with electrical cords to connect to a commercial power source.

The engine block heater and internal battery charger (Figure 83) both require 120 VAC in order to operate. Two power receptacles are provided on the output terminal panel to allow commercial power to be applied.

These units will **ONLY** function when commercial power has been supplied to them. When using extension cords, refer to Table 7 for the correct size and length.

When using the generator in hot climates, there is no need to apply power to the engine block heater (heating element). However, if the generator will be used in cold climates, it is best to apply power to the heater at all times.

If the generator will be used daily, the battery should normally not require charging. If the generator will be idle (not used) for long periods of time, apply power to the battery charger receptacle via commercial power using a power cord of adequate size.

NOTICE

If the generator will be idle (not used) for long periods of time and to ensure adequate starting capability, always have power applied to the generator's internal battery charger.

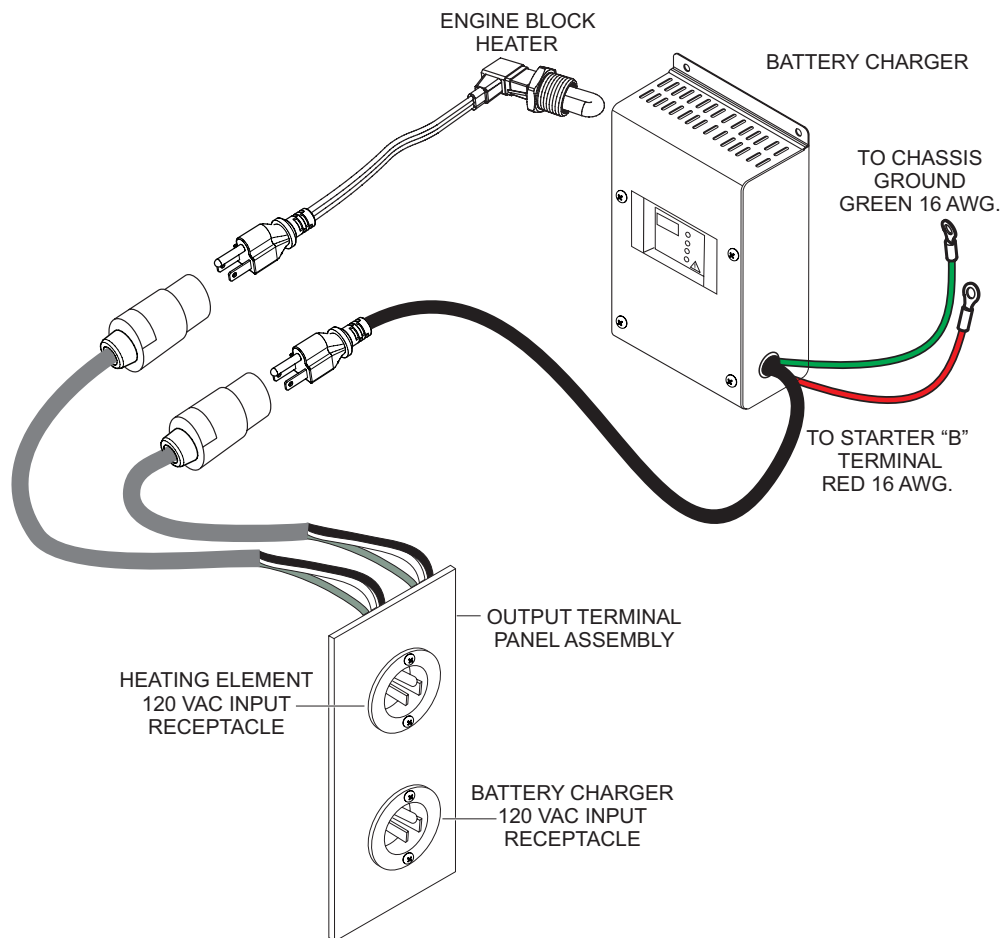

Figure 83. Engine Block Heater And Optional Battery Charger

EMISSION CONTROL

The emission control system employed with the **John Deere 6090HF** diesel engine consists of a **Diesel Oxidation Catalyst (DOC)** and a **Selective Catalytic Reduction (SCR)** catalyst as an exhaust gas after-treatment system that helps reduce harmful gases and destroy the organic fraction of the particulate matter produced from the exhaust gas to meet the requirement for EPA Tier 4 Final regulations.

The DOC device (Figure 84) helps in filtering out large amounts of harmful **Nitrogen Oxides (NOx)** and **Particulate Matter (PM)** which are emitted by diesel engines. These exhaust emissions pose serious environmental and health risks. It is important to maintain and service the DOC emission safety device on a periodic basis.

Diesel Oxidation Catalyst (DOC)

The DOC does not filter particles, it oxidizes them. This catalyst (honeycomb-like structure) uses a chemical process to break down pollutants in the exhaust stream into less harmful components. In general, this catalyst collects/burns accumulated particulates. The DOC contains palladium and platinum which serve as catalysts to oxidize hydrocarbons and carbon monoxide.

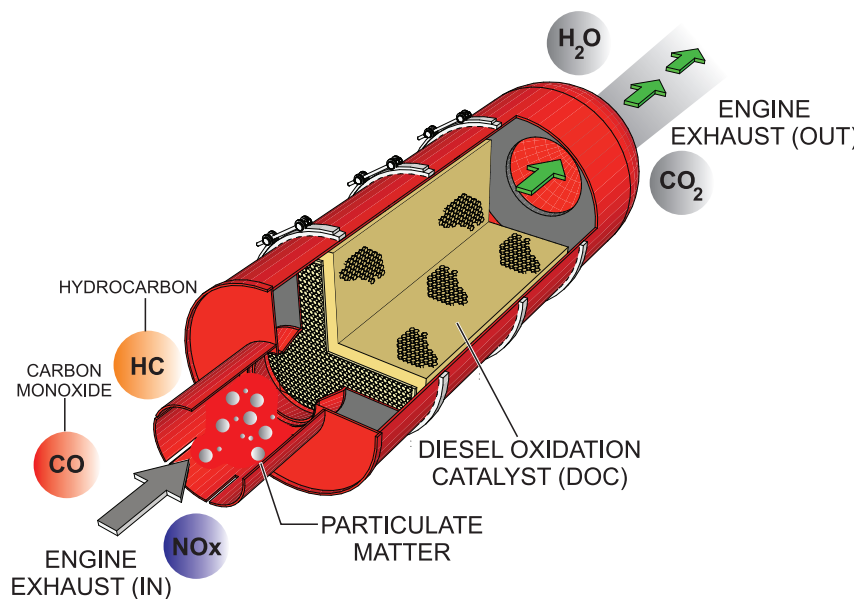

Figure 84. Diesel Oxidation Catalyst (DOC)

PREVENTIVE MAINTENANCE PROGRAMS

Most challenging to a rental organization is the fact that a customer's power assumptions may not meet the minimum load requirements of the power equipment selected. When in doubt, it is always recommended to apply a **load bank application** to the equipment following a longer rental period.

Equipment on extended, long-term contracts needs periodic on-site inspection. If possible, interview the operator and survey the equipment hooked up to the generator to estimate load conditions.

Preventive maintenance and a few extra steps prevent downtime and protect your investment and business. A well-planned preventive maintenance program will reward you with years of service.

SELECTIVE CATALYTIC REDUCTION (SCR)

Diesel engines can be run with a lean burn air-to-fuel ratio, to ensure the full combustion of soot and to prevent the exhaust of unburnt fuel. The excess of air necessarily leads to generation of nitrogen oxides (NO_x), which are harmful pollutants, from the nitrogen in the air. **Selective catalytic reduction (SCR)** is used to reduce the amount of NO_x released into the atmosphere.

Diesel exhaust fluid (DEF) is injected from a separate tank into the exhaust pipeline, where the aqueous urea solution vaporizes and decomposes to form ammonia and carbon dioxide. Within the SCR catalyst, the nitrogen oxides are catalytically reduced by the ammonia (NH_3) into water (H_2O) and nitrogen (N_2), which are both harmless; these are then released through the exhaust.

The SCR system creates a certain amount of ammonia (NH_3) that is stored within the SCR catalyst. During regeneration operations the increase in temperature at regular intervals eliminates the stored ammonia.

The process of keeping accurate ammonia storage amounts is by counting urea injection quantities from the **dosing control unit (DCU)**.

DOC/SCR REGENERATION

Regeneration is a cleaning process that eliminates accumulated DEF deposits from the exhaust system. Under normal conditions where the exhaust temperature is sufficient for urea sublimation, deposits will be removed from the system as quickly as they accumulate. This process does not have any influence on the unit operation and does not require any operator action. However, if this natural cleaning process cannot be achieved due to lighter loads or cold ambient weather conditions for an extended period of time, the accumulated urea must be removed using either the **automatic regeneration** or **forced regeneration** process.

Regeneration Guidelines

For the safe operation of equipment, protection of the surrounding area, and prevention of bodily harm, use the guidelines below when regeneration is required:

- **DO NOT** perform regeneration in conditions where it may be unsafe due to high exhaust temperatures.
- **DO NOT** operate the unit in an area with poor ventilation.
- If operating the engine indoors, install exhaust/ventilation equipment and ensure that there is sufficient ventilation.
- If you begin to feel sick, stop the unit immediately and ventilate the area.
- **Remember** — Due to the emission reduction functions of the exhaust system, exhaust emissions from the tailpipe have a different smell than those emitted from engines without urea SCR systems.
- During the regeneration process, the area above and around the generator should be free of any type of debris or flammable/combustible materials, as temperatures during the regeneration process can reach as high as 1,022°F (550°C).

NOTICE

During DOC/SCR system regeneration, **white smoke** may be temporarily emitted from the exhaust tailpipe. This should not be considered a failure. In addition, the smell of **ammonia** during the regeneration process should not be considered a failure.

If the regeneration process is underway while running a light load (0–30%), the unit may produce unusual sounds. This also should not be considered a failure or malfunction.

Auto Regeneration

This process will automatically occur every 30 minutes. Fuel will be injected into the exhaust stream to elevate the exhaust temperature. No operator action is required for this process. The Exhaust Temperature High indicator (Figure 85) will appear on both ECU-845/670 controllers.

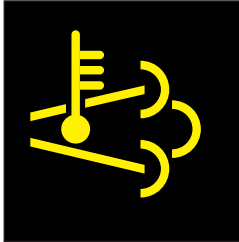

Figure 85. Exhaust Temperature High Indicator

Allow the engine to run for at least 30 minutes to complete the automatic regeneration process.

Manual Forced Regeneration

Force Regeneration is required if the conditions for auto regeneration cannot be achieved and when the urea accumulated in the exhaust system is *high*.

The Regeneration Required indicator (Figure 86) will appear on the ECU-845/670 controllers indicating that Force Regeneration is required. At this point, perform the Force (Manual) Regeneration by following these steps.

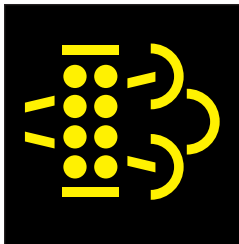

Figure 86. Regeneration Required Indicator

1. Remove all loads from the generator and place all circuits breakers in the OFF position.
2. Press the Program/Exit button on the ECU-845 Controller and select "FORCE REGEN" mode (Figure 87).

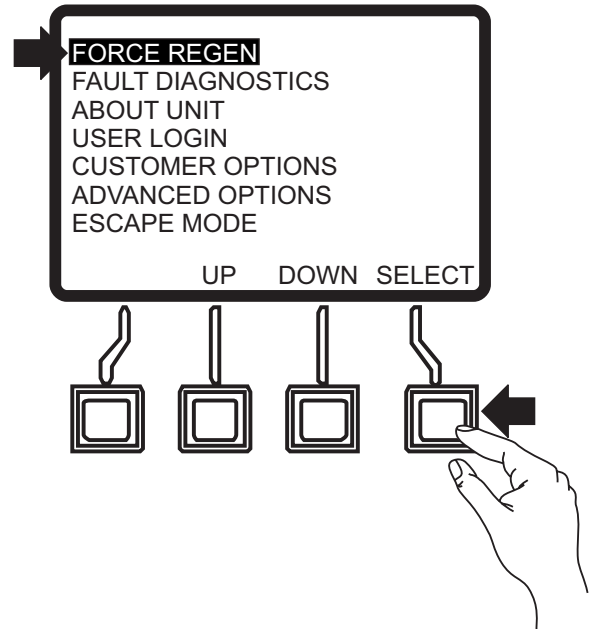

Figure 87. Force Regen Mode

3. Press and hold the "REQUEST" button (Figure 88) until the "REGEN ACTIVE" message is displayed on the monitor and then release button.

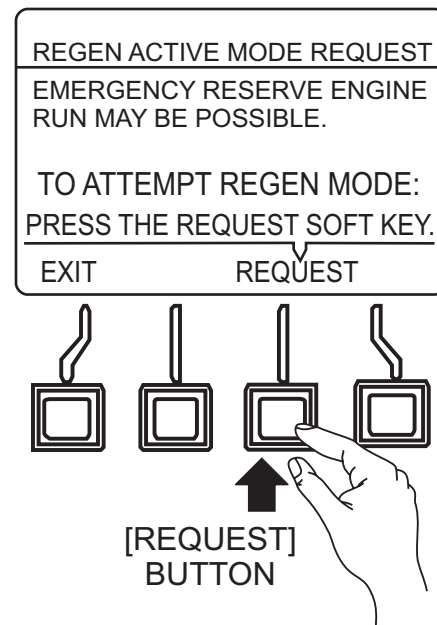

Figure 88. Regen Request

- The regeneration process will start automatically, lasting for at least 30 minutes. The Exhaust Temperature High indicator (Figure 85) and Regeneration Needed Indicator (Figure 86) will appear on both ECU-845/670 controllers during the process and turns off when the regeneration process has been completed.

The Inhibit Regen indicator (Figure 89) will be displayed when regeneration will not occur.

NOTICE

The inhibit regeneration indicator appears in conditions where it may be unsafe for elevating exhaust temperatures.

Inhibit regeneration is only recommended when absolutely necessary.



Figure 89. Inhibit Regen Indicator

DIESEL EXHAUST FLUID (DEF)

If the **diesel exhaust fluid (DEF) symbol** (Figure 90) is displayed during ECU controller operation, it indicates the following:

- DEF tank level is below 10%. Reference Table 16, DEF Level System Action.
- DEF quality is poor. Check DEF tank level and check active **diagnostic trouble codes (DTC)**.

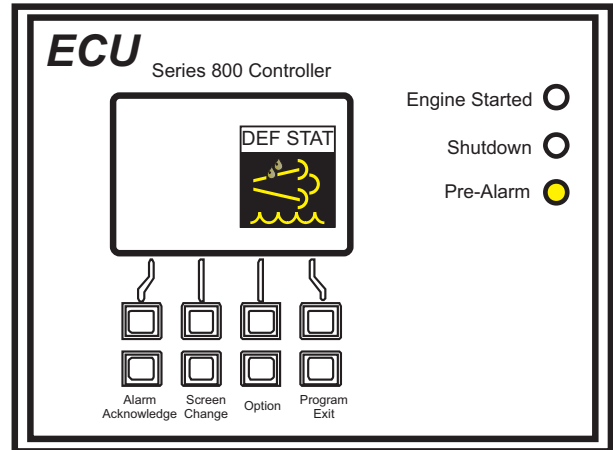

Figure 90. ECU DEF State Pre-Alarm

The amount of fluid in the DEF tank will be shown on the ECU Controller main screen during operation. The symbol shown in Figure 91 will be shown on the ECU monitor indicating the level of fluid in the DEF tank.

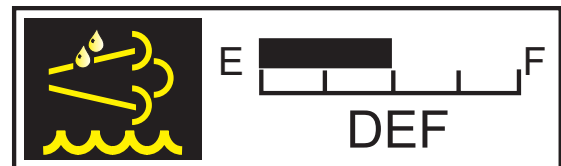

Figure 91. DEF Tank Level Gauge

NOTICE



Models equipped with the **845 Series ECU Controller** will enter emergency shutdown when the DEF level has reached 0% and emergency protective measures are necessary. When this condition exist, the unit can only be restarted after the ESCAPE MODE is activated and the unit will run for 30 minutes. Reference "Escape Mode" section in this manual.

Table 16. DEF Level System Action

DEF Level	Over 10%	Below 10%	0%	Empty or After 4 hrs. From 0%
Controller Message	—	DEF<10% Tank Level	DEF<10% Tank Level	DEF Tank Empty Level
DEF Symbol	—	● ON	● Blinking	● Blinking
Pre-Alarm Lamp	—	—	● ON	● ON
Shutdown Lamp	—	—	—	● ON Engine Shutdown

INDUCEMENT

When the system senses improper usage such as no supply of DEF, use of poor quality DEF, problems with DEF dosing, or disconnection of sensors, a warning will be issued before the situation becomes critical. If the warnings are ignored and the unit enters intermittent operation, the emergency shutdown will activate. The three warning levels are referenced in Table 17:

Table 17. DEF Inducement					
Stage	Controller Message	SCR System Pop-Up	DEF Symbol	Pre-Alarm Lamp	Shutdown Lamp
Stage 1 Warning Level 1	SCR System Malfunction	SCR SYS ERR		● ON	—
Stage 2 Warning Level 2	SCR System Malfunction	SCR SYS ERR	 Slow Blinking	● ON	—
Stage 3 Shutdown ¹	SCR System Malfunction	SCR SYS ERR	 Fast Blinking	● ON	● ON

¹When emergency shutdown occurs, inspection and repair should generally be performed promptly. However, if emergency protective measures are necessary, the unit will enter **ESCAPE MODE** and may require as long as 30 minutes to restart.

HOW TO ACTIVATE ESCAPE MODE

If the ECU displays any messages referenced in Table 18 or Figure 92, it may be necessary to restart via ESCAPE MODE.

VOLTS		AMPS
UO ---	UV ---	U ----
VO ---	VW ---	V ----
WO ---	WU ---	W ----
----- KW		----- KVA
--- HZ		⚙️ 00000.9 h
ADD DEF OR USE ESCAPE MENU		

Figure 92. Add DEF/Escape Menu Screen

Starting

1. Start the Diagnostic Mode as referenced in the “Troubleshooting Diagnostics” section in this manual.
2. Exit the Status Check screen by pressing the [EXIT] button (Figure 93).

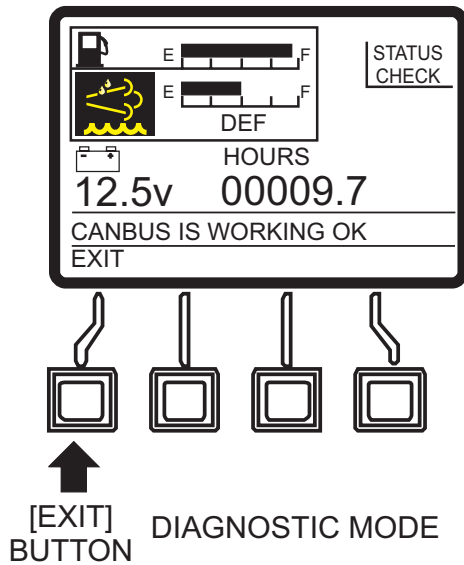

Figure 93. Status Check Screen (Diagnostic Mode)

3. Press the [Program/Exit] button (Figure 94) to enter the Main Menu.

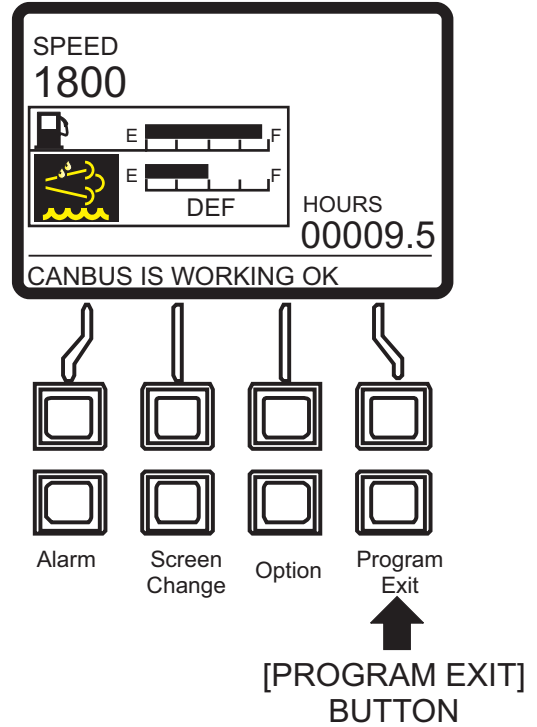

Figure 94. Main Screen

4. Press the [DOWN] button (Figure 95) to scroll to the Escape Mode item.

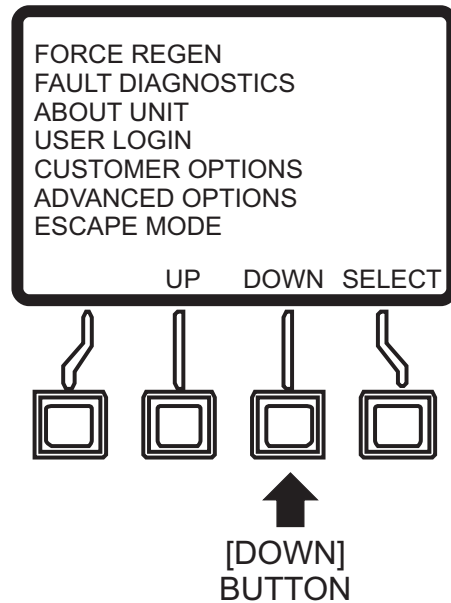

Figure 95. Main Menu (Down Button)

5. Press the **[SELECT]** button (Figure 96) to enter the "Escape Mode" menu.

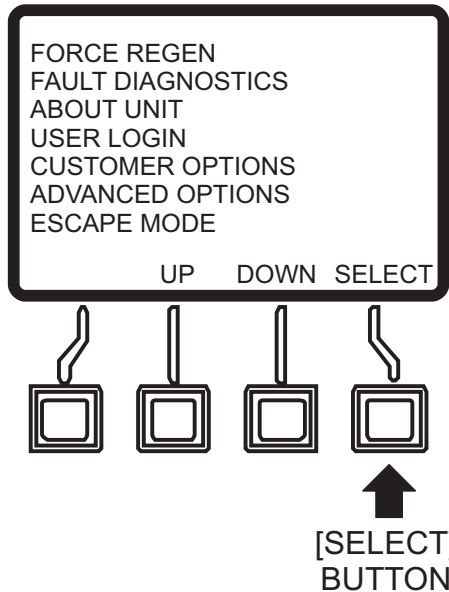

Figure 96. Escape Mode (Select Button)

6. Press the **[REQUEST]** button (Figure 97) to send "Escape Mode Request" signal to ECM.

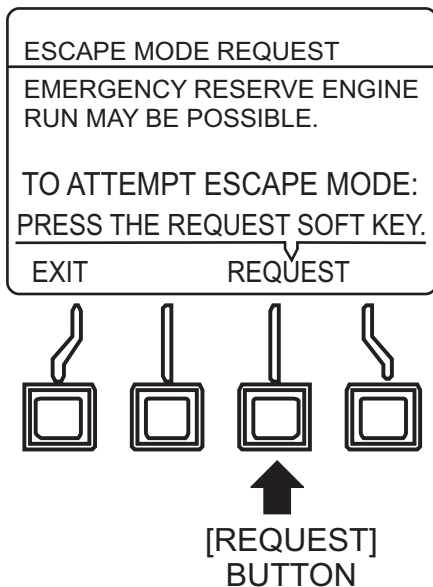

Figure 97. Escape Mode (Request Button)

7. Once the **[REQUEST]** button has been pressed, the display will indicate that escape mode has been activated (Figure 98).

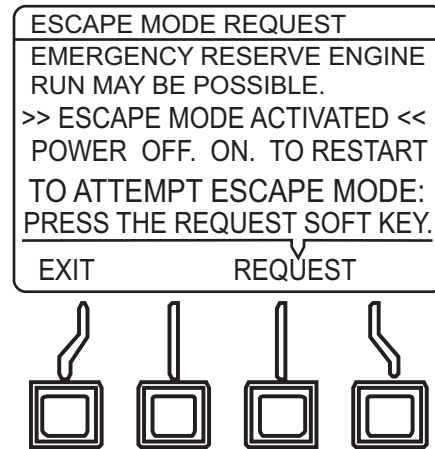

Figure 98. Escape Mode Activated Screen

8. Place the Auto Start/Stop switch (Figure 99) in the "Off/Reset" position.

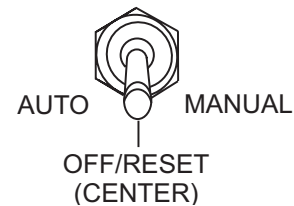

Figure 99. Auto Start/Stop Switch (Off/Reset Position)

9. Place the Auto Start/Stop switch (Figure 100) in the "Manual" position to start the engine.

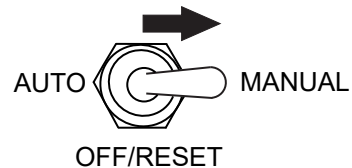

Figure 100. Auto Start/Stop Switch (Manual Position)

10. The **Escape Mode Timer** (Figure 101) will appear on the **main** screen. This timer displays the remaining time the unit can be operated.

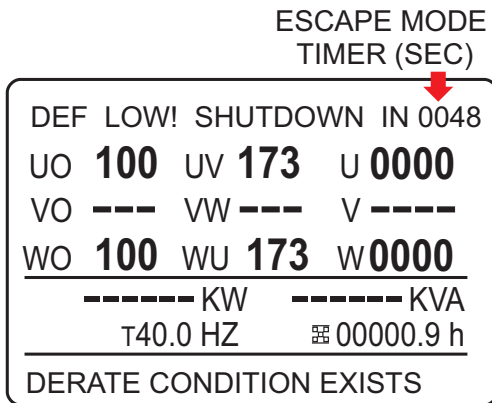

Figure 101. Escape Mode Timer

- If ESCAPE MODE is temporarily suspended, it is not necessary to return to the ESCAPE MODE screen and press the **[REQUEST]** button. ESCAPE MODE operation will be available until around 30 minutes after operation has ended.
- Once the ESCAPE MODE timer reaches zero minutes, the engine will stop since the ESCAPE MODE time has expired. Please perform maintenance to return the unit to proper operating condition.
- If the unit returns to Warning Level 1 while ESCAPE MODE is running, ESCAPE MODE will be cancelled, the ESCAPE MODE timer display will close, and normal operation will resume.

PROTECTION DEVICES

Automatic Shutdown System

This unit is equipped with engine protection devices that automatically shut down the engine if any of the faults shown in Table 18 occur. The “Shutdown” LED on the ECU Controller will turn on just before the shutdown and will stay on after the shutdown. Messages will appear on the ECU display.

After the automatic shutdown, check all Diagnostic Trouble Codes (DTC) displayed on the ECU Controller. Reference the Troubleshooting Diagnostics section in this manual.

Place the Auto Start/Stop Switch in the “Off/Reset” position. In addition, place all circuit breakers in the **OFF** position. Before troubleshooting, allow sufficient time for adequate cooling. Before attempting to restart the generator, perform overall inspection of the generator and correct the problem that caused the shutdown. If necessary, contact your nearest Multiquip dealer for additional technical support.

Restart the generator as referenced in the Generator Start-Up Procedure (Manual Start).

NOTICE

Although the unit is equipped with engine protection devices, regularly scheduled **preventive maintenance** is strongly advised.

Table 18. Automatic Engine Shutdown System

Operating Parameter	ECU Shutdown LED	Operating Condition/Set Point
Low Oil Pressure	● ON	Set Point: 17 psi (117 kPa)
High Water Temperature	● ON	Set Point: 240°F (116°C)
Low Coolant Level	● ON	Falls Below Specified Level
High Water Level in Fuel Water Separator	● ON	Water Level Has Exceeded Filter Capacity
High Engine Fuel Temperature	● ON	Fuel Temperature Too High
High Charged Air Cooler Outlet Temperature	● ON	Fuel Temperature Too High
Exhaust System Severe Malfunction	● ON	Reference Exhaust System, DEF, Regeneration Sections
Over Voltage	● ON	Set Point: 110%
Under Voltage	● ON	Set Point: 75%
High Power (kW)	● ON	Set Point: 115%
Over Frequency (Hz)	● ON	Set Point: 110%
Under Frequency (Hz)	● ON	Set Point: 90%
Over Current	Main CB Trip	Load Capacity Exceeded

TROUBLESHOOTING (DIAGNOSTICS)

845 ECU SERIES CONTROLLER

The engine controller of this generator diagnoses problems that may arise from the engine control system and the engine itself.

1. With the engine stopped (**OFF**), press and hold the **Hour Check button** (Figure 102) located on the control panel.

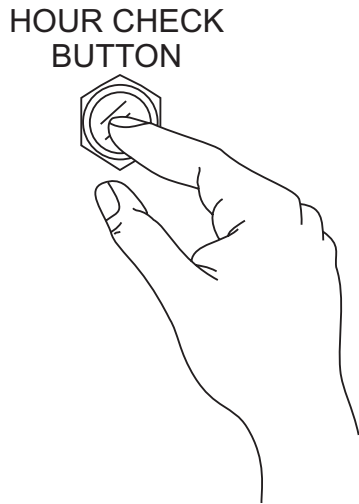

Figure 102. Hour Check Button

2. While keeping the **Hour Check button** pressed, place the **Auto Start/Stop switch** (Figure 103) in the **MANUAL** position.

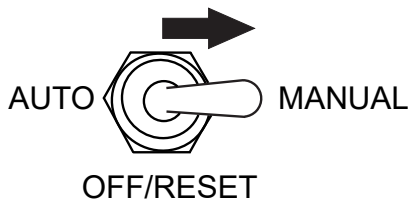

Figure 103. Auto Start/Stop Switch (Manual Position)

3. The **Hour Check Menu screen** will be displayed on the ECU controller.

4. Release the **Hour Check button** and press the **Program Exit button** on the ECU controller to return the controller to the main screen.

PROGRAM EXIT BUTTON

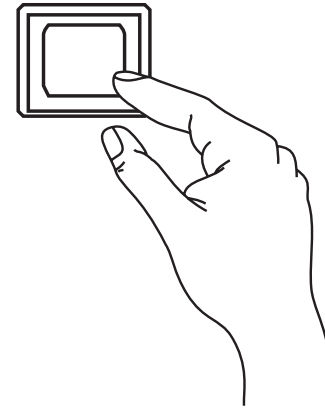

Figure 104. Program Exit Button

5. Push the **Program Exit Button** on the ECU controller and select **Fault Diagnostics** mode. This mode enables the ability to carry out the fault diagnostics as listed below:

- **DM1 Active Faults** — Displays active fault messages and codes.
- **DM2 Messages and Codes** — Displays messages and codes which previously occurred that are recorded in the Engine Control Module (ECM).
- **Last Shutdown** — Displays the messages and codes that caused the most recent shutdown.

6. After performing diagnostic tests, place the **Auto Start/Stop switch** in the **OFF** position.

TROUBLESHOOTING (DIAGNOSTICS)

BASLER DGC2020HD CONTROLLER

At times, it may be useful to power up the Engine Control Module (ECM) with the key switch **ON** while the engine is not running for diagnostic purposes and fault clearing.

To enter **diagnostic mode** with the controller in the **OFF** mode and the engine not running, do the following:

1. Press and hold the **Alarm Silence** and **Lamp Test** buttons (Figure 105) at the same time for 10 seconds.

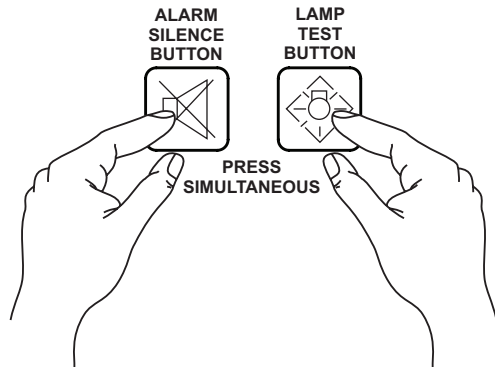

Figure 105. Alarm Silence And Lamp Test Buttons

2. Listen for an audible click inside the control panel which is the **run relay** that controls the key switch.
3. While in diagnostic mode, the controller can see real-time engine CAN bus data including **Diagnostic Trouble Codes** (DTC).
4. To view active DTC codes, navigate to Metering->J1939 ECU->DTC Active Data.
5. For previously active codes, navigate to Metering->J1939 ECU->DTC Prev Data.
6. Real-time ECM parameters are not supported due to lack of sensors etc. and will display NS for No Signal.

7. Diagnostic mode will remain active until the **Reset** button (Figure 106) is pressed or if the engine rpm becomes greater than zero.

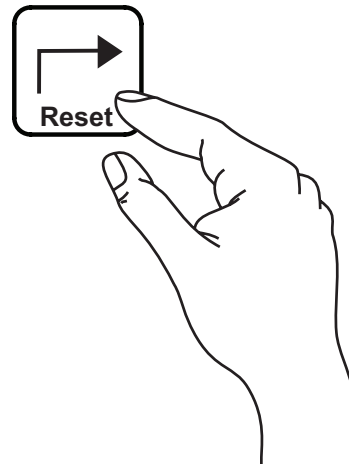

Figure 106. Reset Button

TROUBLESHOOTING (GENERATOR)

Practically all breakdowns can be prevented by proper handling and maintenance inspections, but in the event of a breakdown, use Table 19 shown below for diagnosis of the generator. If the problem cannot be remedied, consult our company's business office or service plant.

Table 19. Generator Troubleshooting		
Symptom	Possible Problem	Solution
No Voltage Output	Defective AC voltmeter?	Check output voltage and replace if necessary.
	Loose wiring connection?	Check wiring and repair.
	Defective AVR?	Replace if necessary.
	Defective rotating rectifier?	Check and replace.
Low Voltage Output	Low engine speed?	Check and adjust.
	Loose wiring connection?	Check wiring and repair.
	Defective AVR?	Replace if necessary.
High Voltage Output	Loose wiring connection?	Check wiring and repair.
	Defective AVR?	Replace if necessary.
Circuit Breaker Tripped	Short circuit in load?	Check load and repair.
	Over current?	Confirm load requirement and reduce.
	Defective circuit breaker?	Check and replace.
	Overcurrent relay actuated?	Confirm load requirement and reset.

TROUBLESHOOTING (ENGINE)

Troubleshooting (Engine)		
Symptom	Possible Problem	Solution
Engine will not start or start is delayed, although engine can be turned over.	No Fuel reaching injection pump?	Add fuel. Check entire fuel system.
	Defective fuel pump?	Replace fuel pump.
	Fuel filter clogged?	Replace fuel filter and clean tank.
	Faulty fuel supply line?	Replace or repair fuel line.
	Compression too low?	Check piston, cylinder and valves. Adjust or repair per engine repair manual.
	Fuel pump not working correctly?	Repair or replace fuel pump.
	Oil pressure too low?	Check engine oil pressure.
	Low starting temperature limit exceeded?	Comply with cold starting instructions and proper oil viscosity.
	Defective battery?	Charge or replace battery.
	Air or water mixed in fuel system?	Check carefully for loosened fuel line coupling, loose cap nut, etc.
At low temperatures engine will not start.	Engine oil too thick?	Refill engine crankcase with correct type of oil for winter environment.
	Defective battery?	Replace battery.
Engine fires but stops soon as starter is switched off.	Fuel filter blocked?	Replace fuel filter.
	Fuel supply blocked?	Check the entire fuel system.
	Defective fuel pump?	Replace fuel pump.
Engine stops by itself during normal operation.	Fuel tank empty?	Add fuel.
	Fuel filter blocked?	Replace fuel filter.
	Defective fuel pump?	Replace fuel pump.
	Mechanical oil pressure shutdown sensor stops the engine due to low oil?	Add oil. Replace low oil shutdown sensor if necessary.
Low engine power, output and speed.	Fuel tank empty?	Replace fuel filter.
	Fuel filter clogged?	Replace fuel filter.
	Fuel tank venting is inadequate?	Ensure that tank is adequately vented.
	Leaks at pipe unions?	Check threaded pipe unions tape and tighten unions as required.
	Speed control lever does not remain in selected position?	See engine manual for corrective action.
	Engine oil level too full?	Correct engine oil level.
	Injection pump wear?	Use No. 2-D diesel fuel only. Check the fuel injection pump element and delivery valve assembly and replace as necessary.

TROUBLESHOOTING (ENGINE)

Troubleshooting (Engine) - continued		
Symptom	Possible Problem	Solution
Low engine power output and low speed, black exhaust smoke.	Air filter blocked?	Clean or replace air filter.
	Incorrect valve clearances?	Adjust valves per engine specification.
	Malfunction at injector?	See engine manual.
Engine overheats.	Too much oil in engine crankcase?	Drain off engine oil down to uppermark on dipstick.
	Entire cooling air system contaminated/ blocked?	Clean cooling air system and cooling fin areas.
	Fan belt broken or elongated?	Change belt or adjust belt tension.
	Coolant insufficient?	Replenish coolant.
	Radiator net or radiator fin clogged with dust?	Clean net or fin carefully.
	Fan, radiator, or radiator cap defective?	Replace defective part.
	Thermostat defective?	Check thermostat and replace if necessary.
Head gasket defective or water leakage?	Replace parts.	

GEN. WIRING DIAGRAM (DCA150SSJU4F2 M3814001403)

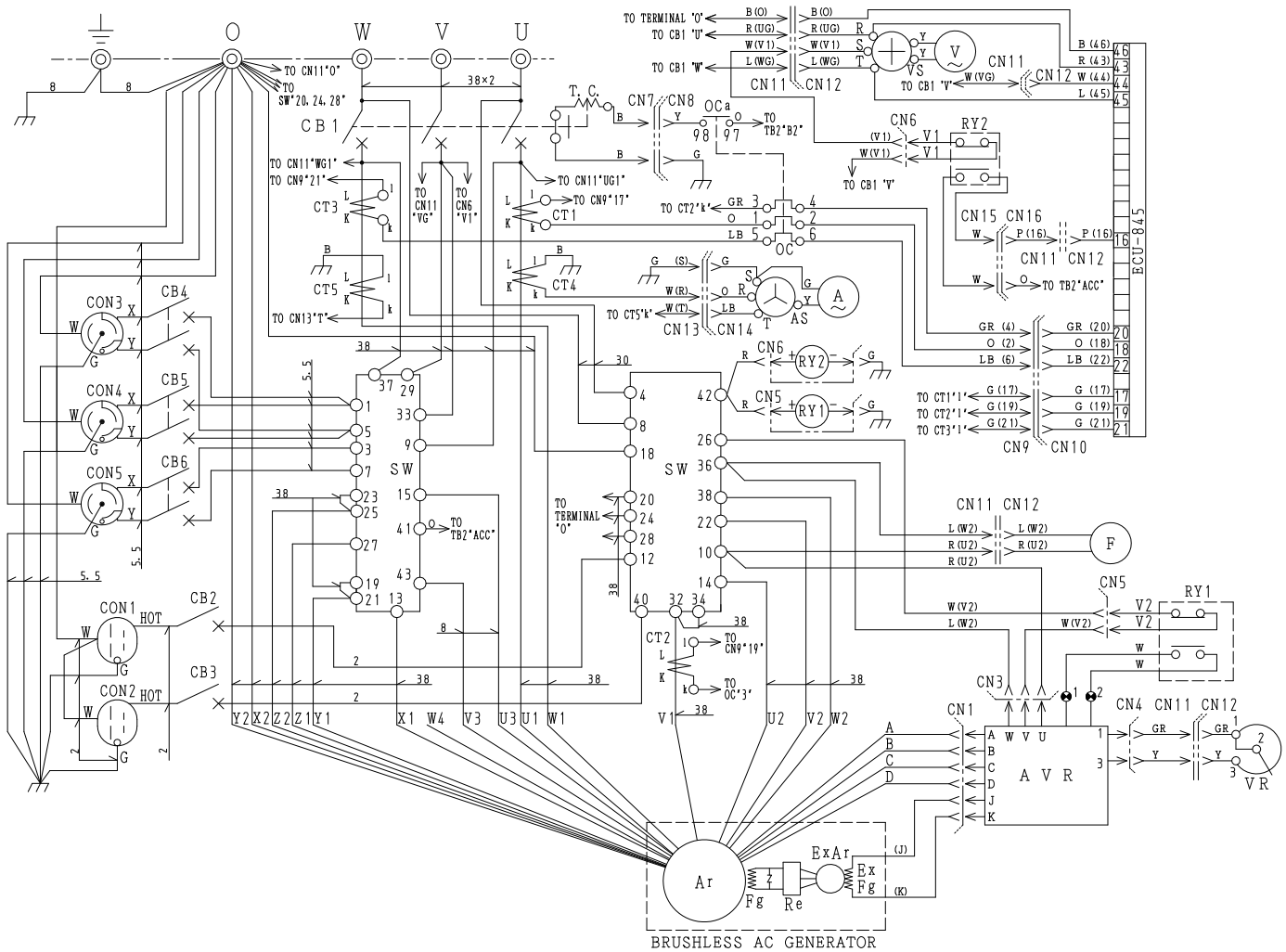

DCA150SSJU4F2
GENERATOR WIRING DIAGRAM NO. M3814001403

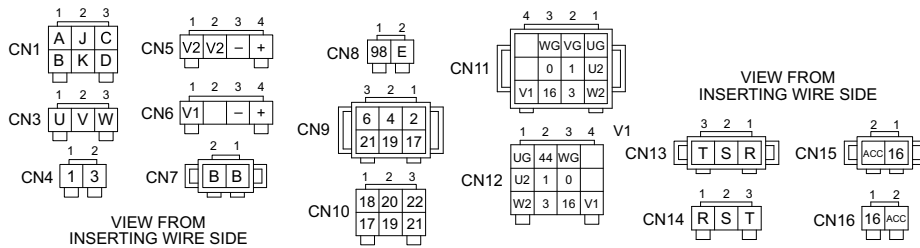

SYMBOL	DESIGNATION
Ar	MAIN GENERATOR ARMATURE WINDING
Fg	MAIN GENERATOR FIELD WINDING
ExAr	EXCITER ARMATURE WINDING
ExFg	EXCITER FIELD WINDING
Re	RECTIFIER
AVR	AUTOMATIC VOLTAGE REGULATOR
VR	VOLTAGE REGULATOR (RHEOSTAT)
CT 1-3	CURRENT TRANSFORMER 300:5A
CT 4-5	CURRENT TRANSFORMER 300:5A
AS	CHANGE-OVER SWITCH, AMMETER
A	AC AMMETER 0-300, 600A
VS	CHANGE-OVER SWITCH, VOLTMETER
V	AC VOLTMETER 0-600V
F	FREQUENCY METER 45-65 Hz
CB 1	CIRCUIT BREAKER, 3P 400A
CB 2-3	CIRCUIT BREAKER, 1P 20A
CB 4-6	CIRCUIT BREAKER, 2P 50A
CON 1-2	RECEPTACLE, GFCI, 125 VAC @ 20A x 2
CON 3-5	RECEPTACLE, CS6369, 250 VAC @ 50A
OC	OVERCURRENT RELAY
SW	SELECTOR SWITCH (12 STAGES)
RY 1-2	RELAY UNIT (12V)

WIRE SIZE	CODE/WIRE COLOR			
38: 38 mm ²	B	BLACK	R	RED
30: 30 mm ²	L	BLUE	W	WHITE
8: 8 mm ²	BR	BROWN	Y	YELLOW
5.5: 5.5 mm ²	G	GREEN	LB	LIGHT BLUE
2: 2 mm ²	GR	GRAY	LG	LIGHT GREEN
NO MARKED	V	VIOLET	O	ORANGE
WIRE SIZE: 1.25 mm ²	P	PINK		

CURRENT TRANSFORMERS (CT 1-5)	
REF. DES.	MARK AT CT
k	X1
l	NO MARK
K	H1
L	NO MARK

GEN. WIRING DIAGRAM (DCA150SSJU4F3 M3814001703)

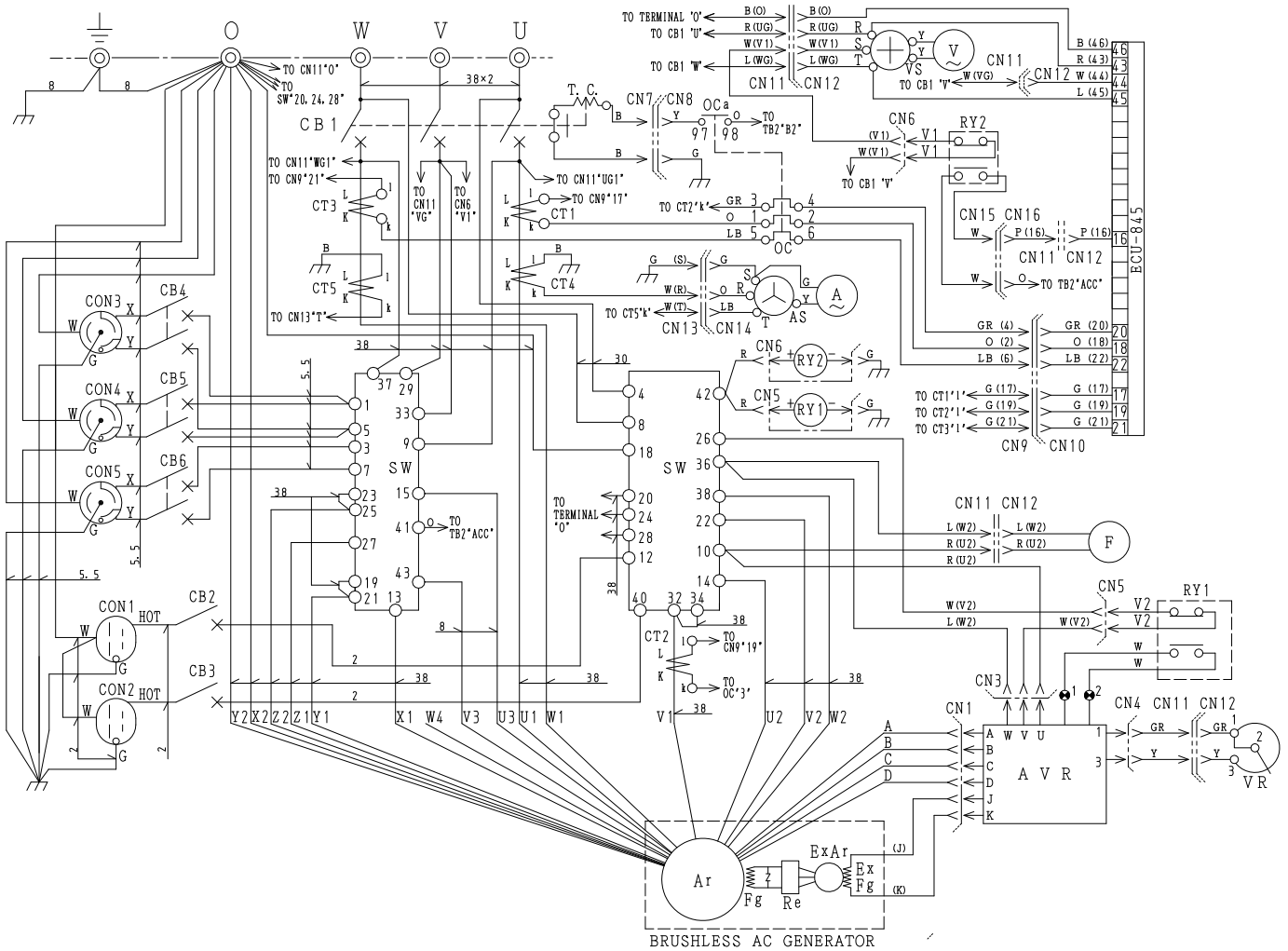

DCA150SSJU4F3
GENERATOR WIRING DIAGRAM NO. M3814001703

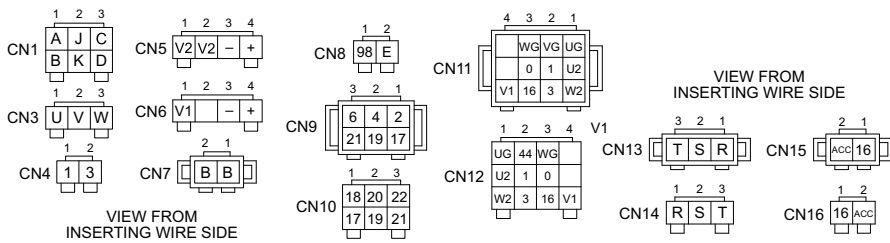

SYMBOL	DESIGNATION
Ar	MAIN GENERATOR ARMATURE WINDING
Fg	MAIN GENERATOR FIELD WINDING
ExAr	EXCITER ARMATURE WINDING
ExFg	EXCITER FIELD WINDING
Re	RECTIFIER
AVR	AUTOMATIC VOLTAGE REGULATOR
VR	VOLTAGE REGULATOR (RHEOSTAT)
CT 1-3	CURRENT TRANSFORMER 300/5A
CT 4-6	CURRENT TRANSFORMER 300/5A
AS	CHANGE-OVER SWITCH, AMMETER
Δ	AC AMMETER 0-300, 600A
Δ	CHANGE-OVER SWITCH, VOLTMETER
∇	AC VOLTMETER 0-600V
F	FREQUENCY METER 45-65 Hz
CB1	CIRCUIT BREAKER, 3P 400A
CB 2-3	CIRCUIT BREAKER, 1P 200A
CB 4-6	CIRCUIT BREAKER, 2P 50A
CON 1-2	RECEPTACLE, GFCL, 125 VAC @ 20A × 2
CON 3-5	RECEPTACLE, CS6369, 250 VAC @ 50A
OC	OVERCURRENT RELAY
SW	SELECTOR SWITCH (12 STAGES)
RY 1-2	RELAY UNIT (12V)

WIRE SIZE	CODE/WIRE COLOR
38: 38 mm ²	B BLACK R RED
30: 30 mm ²	L BLUE W WHITE
8: 8 mm ²	BR BROWN Y YELLOW
5.5: 5.5 mm ²	G GREEN LB LIGHT BLUE
2: 2 mm ²	GR GRAY LG LIGHT GREEN
NO MARKED	V VIOLET O ORANGE
WIRE SIZE: 1.25 mm ²	P PINK

CURRENT TRANSFORMERS (CT 1-5)	
REF. DES.	MARK AT CT
k	X1
l	NO MARK
K	H1
L	NO MARK

NOTICE:
IF MEASURING INSULATION RESISTANCE,
DISCONNECT CN11 AND CN12.

ENG. WIRING DIAGRAM (DCA150SSJU4F2 M3814101703)

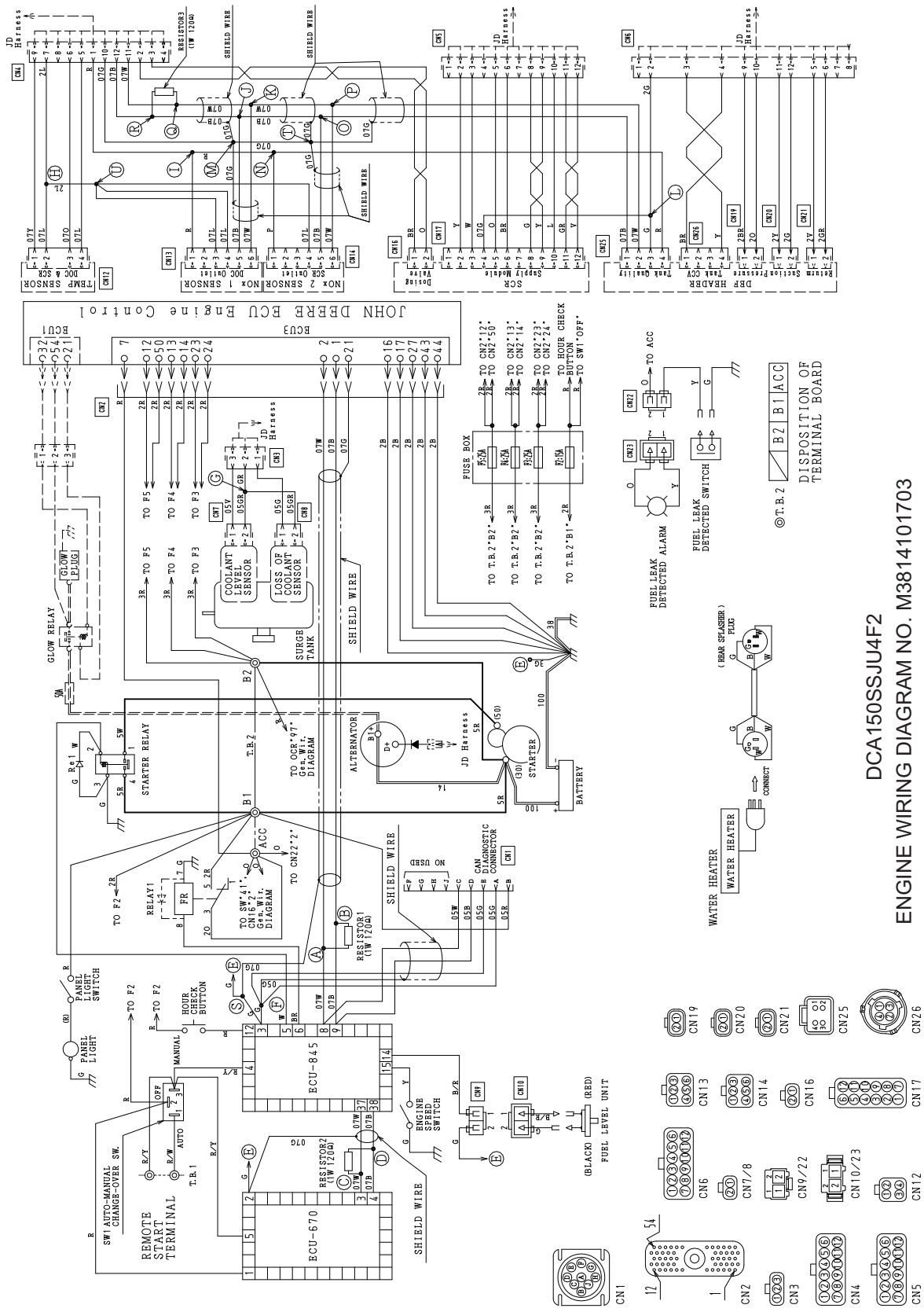

DCA150SSJU4F2
ENGINE WIRING DIAGRAM NO. M3814101703

BATTERY CHARGER WIRING DIAGRAM (OPTION)

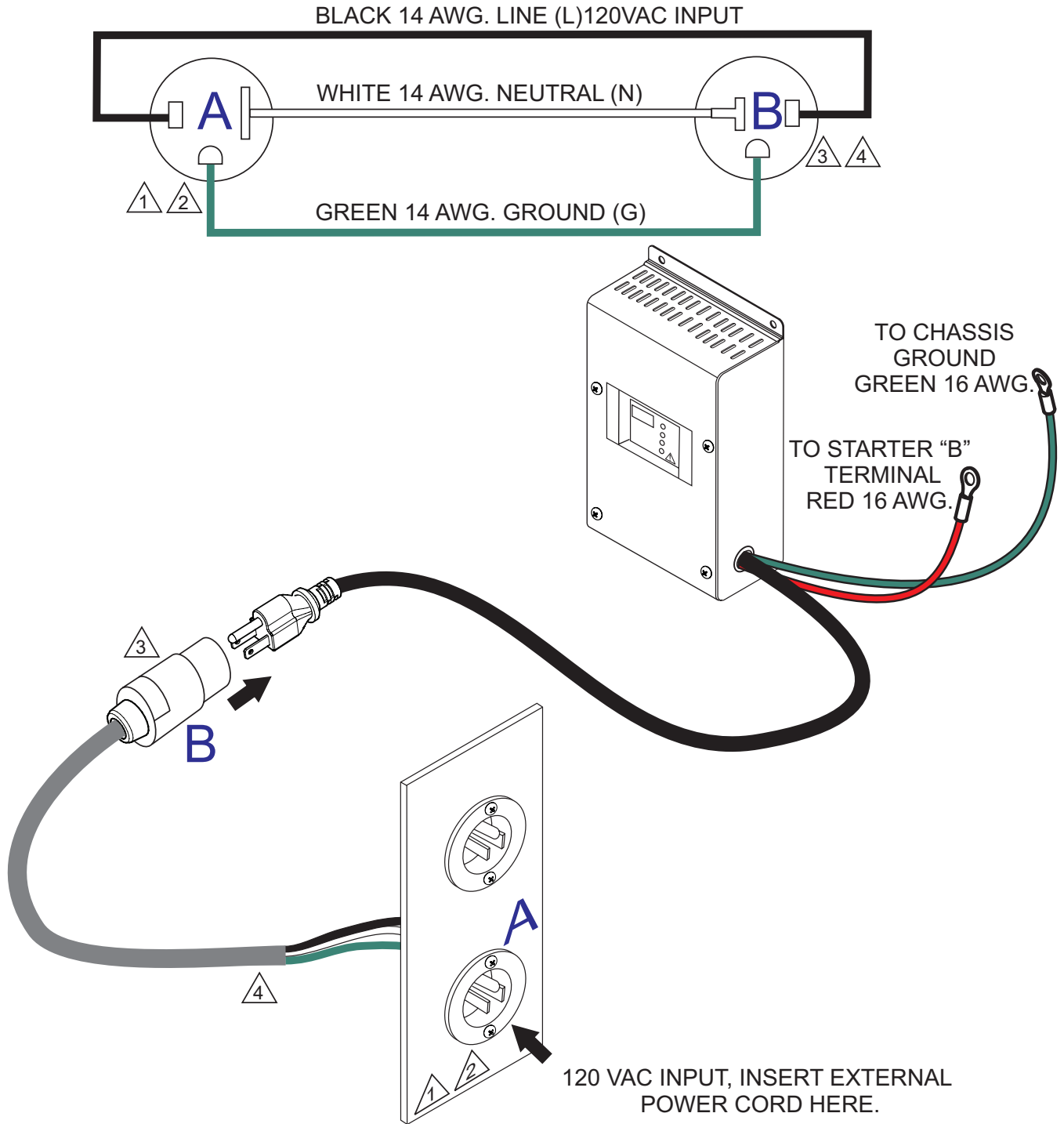

NOTES:

- ① NEMA 5-15, 15A, 120 VAC, P/N HBL5278C/HUBBLE RECEPTACLE.
- ② RECEPTACLE IS MOUNTED ON OUTPUT TERMINAL PANEL ASSY.
- ③ 20 AMP, 5-20R RECEPTACLE, P/N HBL5369C/HUBBLE RECEPTACLE.
- ④ CORD, CAROL 3/C 14 AWG., P/N EE56557.

OPERATION MANUAL

HERE'S HOW TO GET HELP

PLEASE HAVE THE MODEL AND SERIAL
NUMBER ON HAND WHEN CALLING

UNITED STATES

Multiquip Inc.

(310) 537- 3700
6141 Katella Avenue Suite 200
Cypress, CA 90630
E-MAIL: mq@multiquip.com
WEBSITE: www.multiquip.com

CANADA

Multiquip

(450) 625-2244
4110 Industriel Boul.
Laval, Quebec, Canada H7L 6V3
E-MAIL: infocanada@multiquip.com

UNITED KINGDOM

Multiquip (UK) Limited Head Office

0161 339 2223
Unit 2, Northpoint Industrial Estate, Globe Lane,
Dukinfield, Cheshire SK16 4UJ
E-MAIL: sales@multiquip.co.uk

© COPYRIGHT 2025, MULTIQUIP INC.

Multiquip Inc., the MQ logo and the MQ Power logo are registered trademarks of Multiquip Inc. and may not be used, reproduced, or altered without written permission. All other trademarks are the property of their respective owners and used with permission.

This manual MUST accompany the equipment at all times. This manual is considered a permanent part of the equipment and should remain with the unit if resold.

The information and specifications included in this publication were in effect at the time of approval for printing. Illustrations, descriptions, references and technical data contained in this manual are for guidance only and may not be considered as binding. Multiquip Inc. reserves the right to discontinue or change specifications, design or the information published in this publication at any time without notice and without incurring any obligations.

Manufactured for
MQ Power Inc.
by
DENYO MANUFACTURING CORP.

