

# OPERATION MANUAL



## **WHISPERWATT™ SERIES MODEL DCA70SSJU4F 60Hz GENERATOR (JOHN DEERE 4045HFG04 DIESEL ENGINE)**

INSTRUCTION MANUAL NO. M2844300014A

Revision #6 (11/07/23)

To find the latest revision of this publication or  
associated parts manual, visit our website at:

[www.mqpower.com](http://www.mqpower.com)



**THIS MANUAL MUST ACCOMPANY THE EQUIPMENT AT ALL TIMES.**

# PROPOSITION 65 WARNING

---



## **DCA70SSJU4F 60 Hz Generator**

Proposition 65 Warning .....	2
Table of Contents.....	3
Safety Decals .....	4
Safety Information .....	5–10
Specifications .....	11
Dimensions.....	12
Installation .....	14–15
General Information.....	16
Major Components .....	17
Engine Control Unit (ECU) .....	18
Engine/Generator Control Panel .....	19
Output Terminal Panel Familiarization.....	20–22
Load Application .....	23
PowerBalance® .....	24
Generator Outputs.....	25–26
Output Terminal Panel Connections .....	27–28
Inspection/Setup.....	29–34
Generator Start-Up Procedure (Manual) .....	35–36
Generator Start-Up Procedure (Auto Mode).....	37
Generator Shutdown Procedure.....	38
Maintenance .....	39–55
Troubleshooting (Diagnostics).....	56
Troubleshooting (Generator) .....	57
Troubleshooting (Engine) .....	58–59
Generator Wiring Diagram (M2814000323) .....	60
Engine Wiring Diagram (M2814100513) .....	61
Battery Charger Wiring Diagram (Option) .....	62

# SAFETY DECALS

## SAFETY DECALS

Safety decals are attached to the generator as shown in Figure 1. Keep these safety decals clean at all times. When the safety decals become worn or damaged, contact your nearest dealer or the Multiquip Parts Department.

**NOTICE**  
For safety decal part numbers, refer to the associated parts manual.

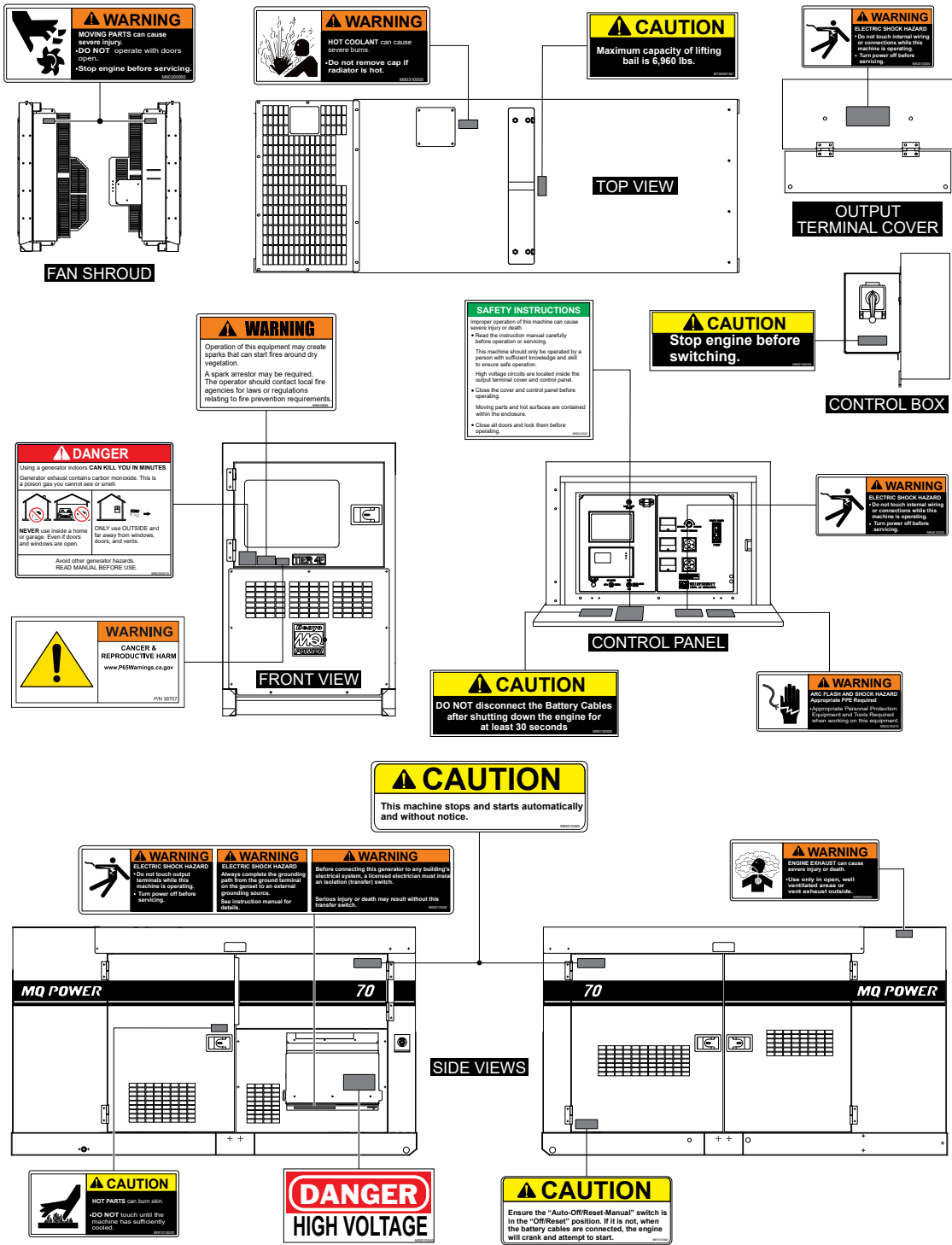

Figure 1. Safety Decals

# SAFETY INFORMATION

Do not operate or service the generator before reading the entire manual. Safety precautions should be followed at all times when operating this generator. Failure to read and understand the safety messages and operating instructions could result in injury to yourself and others.

## SAFETY MESSAGES

The four safety messages shown below will inform you about potential hazards that could injure you or others. The safety messages specifically address the level of exposure to the operator and are preceded by one of four words: **DANGER**, **WARNING**, **CAUTION** or **NOTICE**.

## SAFETY SYMBOLS

 **DANGER**

Indicates a hazardous situation which, if not avoided, **WILL** result in **DEATH** or **SERIOUS INJURY**.

 **WARNING**

Indicates a hazardous situation which, if not avoided, **COULD** result in **DEATH** or **SERIOUS INJURY**.







 **CAUTION**

Indicates a hazardous situation which, if not avoided, **COULD** result in **MINOR** or **MODERATE INJURY**.

**NOTICE**

Addresses practices not related to personal injury.

Potential hazards associated with the operation of this generator will be referenced with hazard symbols which may appear throughout this manual in conjunction with safety messages.

Symbol	Safety Hazard
	Lethal exhaust gas hazards
	Explosive fuel hazards
	Burn hazards
	Overspeed hazards
	Rotating parts hazards
	Pressurized fluid hazards
	Electric shock hazards

# SAFETY INFORMATION

## GENERAL SAFETY

### ⚠ CAUTION

- **NEVER** operate this generator without proper protective clothing, shatterproof glasses, respiratory protection, hearing protection, steel-toed boots and other protective devices required by the job or city and state regulations.





- **NEVER** operate this generator when not feeling well due to fatigue or illness, or when on medication. 
- **NEVER** operate this generator under the influence of drugs or alcohol.



- **ALWAYS** check the generator for loosened threads or bolts before starting.
- **NEVER** use the generator for any purpose other than its intended purposes or applications.

### NOTICE

- This generator should only be operated by trained and qualified personnel 18 years of age and older.
- Whenever necessary, replace nameplate, operation and safety decals when they become difficult to read.
- Manufacturer does not assume responsibility for any accident due to equipment modifications. Unauthorized modification of the generator will void all warranties.
- **NEVER** use accessories or attachments that are not recommended by MQ Power for this generator. Damage to the generator and/or injury to the user may result.
- **ALWAYS** know the location of the nearest **fire extinguisher**. 
- **ALWAYS** know the location of the nearest **first aid kit**. 

- **ALWAYS** know the location of the nearest phone or **keep a phone on the job site**. Also, know the phone numbers of the nearest **ambulance, doctor, and fire department**. This information will be invaluable in the case of an emergency.

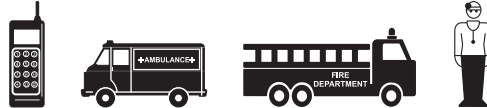

## GENERATOR SAFETY

### ⚠ DANGER

- **NEVER** operate the generator in an explosive atmosphere or near combustible materials. An explosion or fire could result causing **severe bodily harm or even death**. 

### ⚠ WARNING

- **NEVER** disconnect any **emergency or safety devices**. These devices are intended for operator safety. Disconnection of these devices can cause **severe injury, bodily harm or even death**. Disconnection of any of these devices will void all warranties.

### ⚠ CAUTION

- **NEVER** lubricate components or attempt service on a **running generator**.

### NOTICE

- **ALWAYS** ensure the generator is on level ground before use.
- **ALWAYS** keep the generator in proper running condition.
- Fix damage to the generator and replace any broken parts immediately.
- **ALWAYS** store the generator properly when it is not being used. The generator should be stored in a clean, dry location out of the reach of children and unauthorized personnel.

# SAFETY INFORMATION

## ENGINE SAFETY

### DANGER

■ The engine fuel exhaust gases contain poisonous carbon monoxide. This gas is colorless and odorless, and can cause **death** if inhaled.

■ The engine of this generator requires an adequate, free flow of cooling air. **NEVER** operate this equipment in any enclosed or narrow area where free flow of the air is restricted. If the air flow is restricted it will cause injury to people and property and serious damage to the equipment or engine.

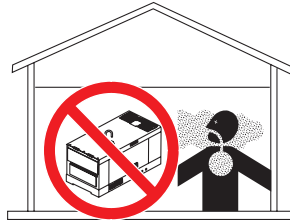

■ When operating the generator outdoors, **DO NOT** place the generator near doors, windows or vents that could allow carbon monoxide to enter and build up in occupied spaces.

### WARNING

■ **NEVER** place hands or fingers inside the engine compartment when the engine is running.

■ **NEVER** operate the engine with heat shields or guards removed.

■ Keep fingers, hands, hair and clothing away from all moving parts to prevent injury.



■ **NEVER** operate the generator with the doors open. Stop the engine before servicing.

■ **DO NOT** remove the radiator cap while the engine is hot. High pressure boiling water will gush out of the radiator and severely scald any persons in the general area of the generator.



■ **DO NOT** remove the coolant drain plug while the engine is hot. Hot coolant will gush out of the coolant tank and severely scald any persons in the general area of the generator.

■ **DO NOT** drain the engine oil while the engine is hot. Hot oil will gush out and severely scald any persons near the generator.

■ Operation of the generator may create sparks that can start fires around dry vegetation. A spark arrestor may be required. The operator should contact local fire agencies for laws or regulations relating to fire prevention requirements.

### CAUTION

■ **NEVER** touch the hot exhaust manifold, muffler or cylinder. Allow these parts to cool before servicing the generator.



### NOTICE

■ **NEVER** run the engine without an air filter or with a dirty air filter. Severe engine damage may occur. Service the air filter frequently to prevent engine malfunction.

■ **NEVER** tamper with the factory settings of the engine or engine governor. Damage to the engine or generator can result if operating in speed ranges above the maximum allowable.



■ Wet stacking is a common problem with diesel engines which are operated for extended periods with light or no load applied. When a diesel engine operates without sufficient load (less than 30-35% of the rated output), it will not operate at its optimum temperature. This will allow unburned fuel to accumulate in the exhaust system, which can foul the fuel injectors, engine valves and exhaust system, including turbochargers, and reduce the operating performance.

In order for a diesel engine to operate at peak efficiency, it must be able to provide fuel and air in the proper ratio and at a high enough engine temperature for the engine to completely burn all of the fuel.

Wet stacking does not usually cause any permanent damage and can be alleviated if additional load is applied to relieve the condition. It can reduce the system performance and increase maintenance. Applying an increasing load over a period of time until the excess fuel is burned off and the system capacity is reached usually can repair the condition. This can take several hours to burn off the accumulated unburned fuel.

# SAFETY INFORMATION

## FUEL SAFETY

### DANGER

- **NEVER** start the engine near spilled fuel or combustible fluids. Diesel fuel is extremely flammable and its vapors can cause an explosion if ignited.
- **ALWAYS** refuel in a well-ventilated area, away from sparks and open flames.
- **ALWAYS** use extreme caution when working with **flammable** liquids.
- **NEVER** fill the fuel tank while the engine is **running** or **hot**.
- **NEVER** overfill the fuel tank. Spilled fuel can ignite if it comes into contact with hot engine parts or sparks from the ignition system.
- Store fuel in appropriate containers, in well-ventilated areas and away from sparks and flames.
- **NEVER** use fuel as a cleaning agent.
- **NEVER** smoke around or near the equipment. Fire or explosion could result from fuel vapors or if fuel is spilled on a hot engine.



## TOWING SAFETY

### CAUTION

- Check with your local county or state safety towing regulations, in addition to meeting **Department of Transportation (DOT) Safety Towing Regulations**, before towing your generator.
- Refer to the MQ Power trailer manual for additional safety information.
- In order to reduce the possibility of an accident while transporting the generator on public roads, **ALWAYS** make sure that the trailer that supports the generator and the towing vehicle are both mechanically sound and in good operating condition.
- **ALWAYS** shut down the engine before transporting.



- Make sure the hitch and coupling of the towing vehicle are rated equal to or greater than the trailer **gross vehicle weight rating**.
- **ALWAYS** inspect the hitch and coupling for wear. **NEVER** tow a trailer with defective hitches, couplings, chains, etc.
- Check the tire air pressure on both the towing vehicle and the trailer. **Inflate trailer tires as indicated on side wall of tire**. Also check the tire tread wear on both vehicles.
- **ALWAYS** make sure the trailer is equipped with **safety chains**.
- **ALWAYS** properly attach the trailer's safety chains to the towing vehicle.
- **ALWAYS** make sure the vehicle and trailer directional, backup, brake, and trailer lights are connected and working properly.
- DOT requirements include the following:
  - Connect and test electric brake operation.
  - Secure portable power cables in cable tray with tie wraps.
- The maximum speed for highway towing is **55 MPH** unless posted otherwise. Recommended off-road towing is not to exceed **15 MPH** or less depending on the type of terrain.
- Avoid sudden stops and starts. These can cause skidding or jackknifing. Smooth, gradual starts and stops will improve towing.
- Avoid sharp turns to prevent rolling.
- The trailer should be adjusted to a level position at all times when towing.
- Raise and lock the trailer wheel stand in the upright position when towing.
- Place **chock blocks** underneath the wheels to prevent **rolling** while parked.
- Place **support blocks** underneath the trailer's bumper to prevent **tipping** while parked.
- Use the trailer's swivel jack to adjust the trailer height to a level position while parked.

# SAFETY INFORMATION

## ELECTRICAL SAFETY

### DANGER

- **NEVER** touch the output terminals during operation. Contact with the output terminals during operation can cause **electrocution, electrical shock, or burn**.



- The electrical voltage required to operate the generator can cause **severe injury or even death** through physical contact with live circuits. Turn the generator and all circuit breakers **OFF** before performing maintenance on the generator or making contact with the output terminals.

- **NEVER** insert any objects into the output receptacles during operation. This is extremely dangerous. The possibility exists of **electrical shock, electrocution or death**.



- Backfeed to a utility system can cause **electrocution** and/or property damage. **NEVER** connect the generator to a building's electrical system without a transfer switch or other approved device. All installations should be performed by a **licensed electrician** in accordance with all applicable laws and electrical codes. Failure to do so could result in electrical shock or burn, causing **serious injury or even death**.



## Power Cord/Cable Safety

### DANGER

- **NEVER** let power cords or cables **lay in water**.
- **NEVER** stand in water while AC power from the generator is being transferred to a load.
- **NEVER** use **damaged** or **worn** cables or cords when connecting equipment to the generator. Inspect the insulation for cuts.
- **NEVER** grab or touch a live power cord or cable with wet hands. The possibility exists of **electrical shock, electrocution or death**.

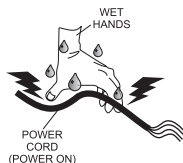

- Make sure power cables are securely connected to the generator's output receptacles. Incorrect connections may cause electrical shock and damage to the generator.

### NOTICE

- **ALWAYS** make certain that the proper power or extension cord has been selected for the job. See the Cable Selection Chart in this manual.

## Grounding Safety

### DANGER

- **ALWAYS** make sure that electrical circuits are properly grounded to a suitable earth ground (ground rod) per the National Electrical Code (NEC) and local codes before operating the generator. **Severe injury or death by electrocution** can result from operating an ungrounded generator.
- **NEVER** use gas piping as an electrical ground.

## BATTERY SAFETY

### DANGER

- **DO NOT** drop the battery. There is a possibility that the battery will explode.
- **NEVER** expose the battery to open flames, sparks, cigarettes, etc. The battery contains combustible gases and liquids. If these gases and liquids come into contact with a flame or spark, an explosion could occur.



### WARNING

- **ALWAYS** wear safety glasses when handling the battery to avoid eye irritation. The battery contains acids that can cause injury to the eyes and skin.
- Use well-insulated gloves when picking up the battery.
- **ALWAYS** keep the battery charged. If the battery is not charged, combustible gas will build up.
- **ALWAYS** recharge the battery in a well-ventilated environment to avoid the risk of a dangerous concentration of combustible gases.
- If the battery liquid (dilute sulfuric acid) comes into contact with **clothing or skin**, rinse skin or clothing immediately with plenty of water.



# SAFETY INFORMATION

- If the battery liquid (dilute sulfuric acid) comes into contact with **eyes**, rinse eyes immediately with plenty of water and contact the nearest doctor or hospital to seek medical attention.

## CAUTION

- **ALWAYS** disconnect the **NEGATIVE** battery terminal before performing service on the generator.
- **ALWAYS** keep battery cables in good working condition. Repair or replace all worn cables.

## ENVIRONMENTAL SAFETY/DECOMMISSIONING

### NOTICE

Decommissioning is a controlled process used to safely retire a piece of equipment that is no longer serviceable. If the equipment poses an unacceptable and unreparable safety risk due to wear or damage or is no longer cost effective to maintain (beyond life-cycle reliability) and is to be decommissioned (demolition and dismantlement), be sure to follow the rules below:

- **NEVER** pour waste or oil directly onto the ground, down a drain, or into any water source.
- Contact your country's Department of Public Works or recycling agency in your area and arrange for proper disposal of any electrical components, waste or oil associated with this equipment.
- When the life cycle of this equipment is over, remove the battery and bring it to an appropriate facility for lead reclamation. Use safety precautions when handling batteries that contain sulfuric acid.
- When the life cycle of this equipment is over, it is recommended that the frame and all other metal parts be sent to a recycling center.



Metal recycling involves the collection of metal from discarded products and its transformation into raw materials to use in manufacturing a new product.

Recyclers and manufacturers alike promote the process of recycling metal. Using a metal recycling center promotes energy cost savings.

## EMISSIONS INFORMATION

### NOTICE

The diesel engine used in this equipment has been designed to reduce harmful levels of carbon monoxide (CO), hydrocarbons (HC), and nitrogen oxides (NOx) contained in diesel exhaust emissions.

This engine has been certified to meet US EPA evaporative emissions requirements in the installed configuration.

Attempting to modify or make adjustments to the engine emission system by unauthorized personnel without proper training could damage the equipment or create an unsafe condition.

Additionally, modifying the fuel system may adversely affect evaporative emissions, resulting in fines or other penalties.

### Emission Control Label

The emission control label is an integral part of the emission system and is strictly controlled by regulations.

The label must remain with the engine for its entire life.

If a replacement emission label is needed, please contact your authorized engine distributor.

# SPECIFICATIONS

**Table 1. Generator Specifications**

<b>Model</b>	DCA70SSJU4F	
<b>Type</b>	Revolving field, self-ventilated, protected type synchronous generator	
<b>Armature Connection</b>	<b>Star with Neutral</b>	<b>Zigzag</b>
<b>Phase</b>	3Ø	1Ø
<b>Standby Output</b>	62 kW (77 kVA)	44 kW
<b>Prime Output</b>	56 kW (70 kVA)	40 kW
<b>3Ø Voltage L-L/L-N) Voltage Selector Switch at 3Ø 240/139</b>	208Y/120, 220Y/127, 240Y/139	N/A
<b>3Ø Voltage L-L/L-N) Voltage Selector Switch at 3Ø 480/277</b>	416Y/240, 440Y/254, 480Y/277	N/A
<b>1Ø Voltage L-L/L-N) Voltage Selector Switch at 1Ø 240/120</b>	N/A	240/120
<b>Power Factor</b>	0.8	1.0
<b>Frequency</b>	60 Hz	
<b>Speed</b>	1,800 rpm	
<b>Aux. AC Power</b>	Single phase, 60 Hz	
<b>Subtransient</b>	0.085	
<b>Transient</b>	0.203	
<b>Synchronous</b>	1.942	
<b>Zero Sequence Reactance</b>	0.0081	
<b>Overload Protection</b>	OCR/main circuit breaker	
<b>Aux. Voltage/Output</b>	120V/4.8 kW (2.4 kW × 2)	
<b>Dry Weight</b>	3,539 lb. (1,605 kg)	
<b>Wet Weight</b>	3,859 lb. (1,750 kg)	

**Table 2. Engine Specifications**

<b>Model</b>	John Deere 4045HFG04 Final Tier 4	
<b>Type</b>	Water-cooled, direct injection, turbo-charged and cooled EGR, DOC and SCR	
<b>No. of Cylinders</b>	4	
<b>Bore × Stroke</b>	4.17 in. × 5.00 in. (106 mm × 127 mm)	
<b>Displacement</b>	275 cu. in. (4.5 liters)	
<b>Rated Output</b>	97 hp at 1,800 rpm	
<b>Starting</b>	Electric	
<b>Coolant Capacity</b>	6.3 gal. (23.7 liters) <sup>1</sup>	
<b>Lube Oil Capacity</b>	3.9 gal. (15 liters) <sup>2</sup>	
<b>Lubricating Type Oil</b>	API service class CJ-4 SAE 15W-40	
<b>DEF Tank Capacity</b>	7.95 gal. (30.1 liters)	
<b>Fuel Type</b>	#2 diesel fuel (ultra low sulfur diesel fuel only)	
<b>Fuel Tank Capacity</b>	20 gal. (75 liters)	
<b>Fuel Consumption</b>	4.6 gal. (17.5 L)/hr. at <b>full load</b>	3.6 gal. (13.8 L)/hr. at <b>3/4 load</b>
	2.7 gal. (10.4 L)/hr. at <b>1/2 load</b>	2.0 gal. (7.6 L)/hr. at <b>1/4 load</b>
<b>Battery</b>	27D CCA 0°F (840A) × 1	

<sup>1</sup> Includes engine and radiator hoses

<sup>2</sup> Includes filters

# DIMENSIONS

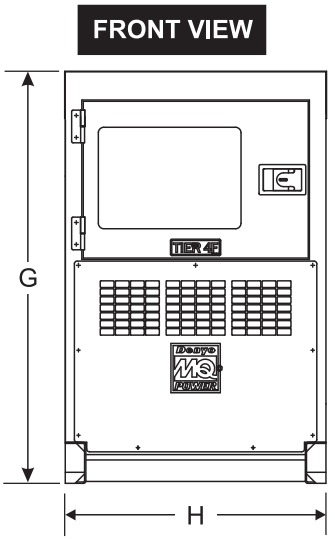
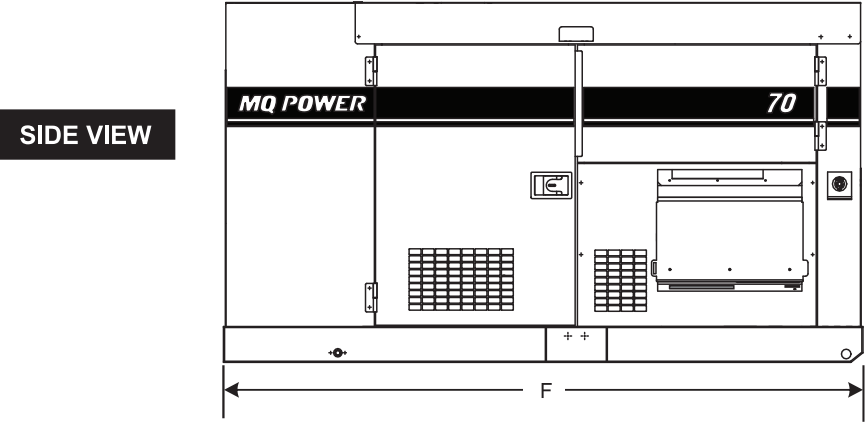
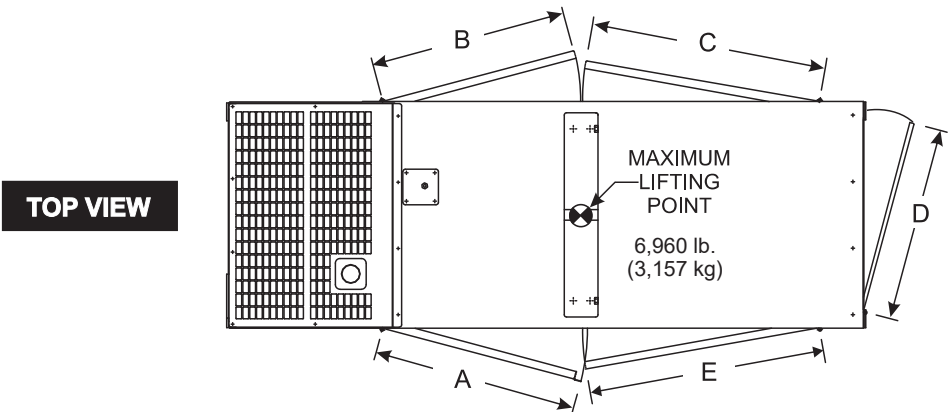

Figure 2. Dimensions

Table 3. Dimensions			
Reference Letter	Dimension in. (mm)	Reference Letter	Dimension in. (mm)
A	33.98 (863)	E	39.25 (997)
B	32.80 (833)	F	105.12 (2,670)
C	39.25 (997)	G	59.05 (1,500)
D	32.28 (820)	H	37.40 (950)



# INSTALLATION

## GENERATOR GROUNDING

**ALWAYS** refer to Article 250 (Grounding and Bonding) of the National Electrical Code (NEC).

**NOTICE**  
**ALWAYS** check with state, province, district, and municipalities for electrical grounding requirements before using the generator.

## Connecting The Ground

Consult with local electrical and safety codes for proper connection based on condition of use. Refer to the Conductor Grounding Table, Article 250 of the NEC handbook.

**EXAMPLE** of how to ground the unit (Figure 3) if the condition of use requires such a device:

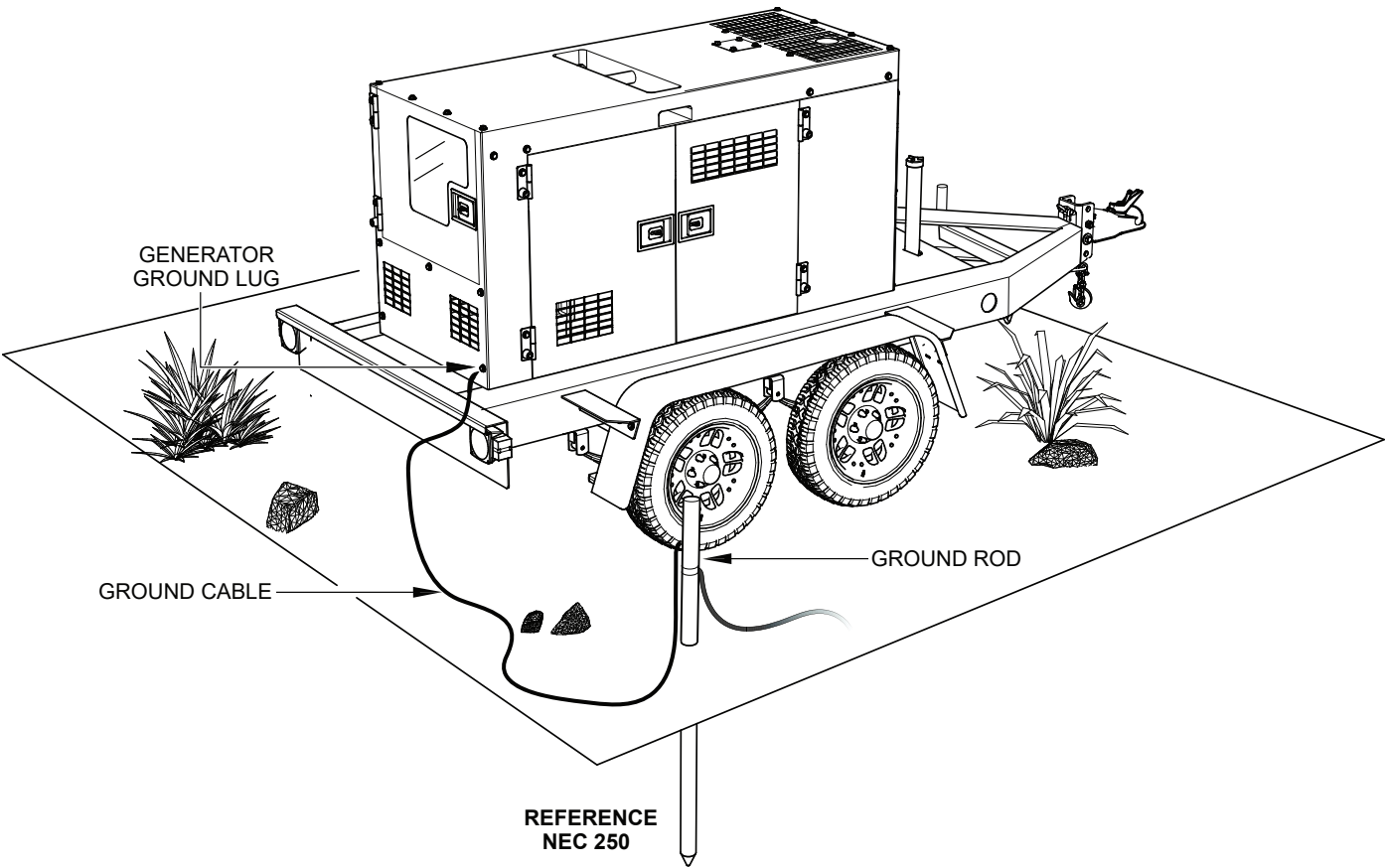

Figure 3. Typical Generator Grounding Application

**NOTICE**  
Trailer-mounted generators are the sole responsibility of MQ Power.

## OUTDOOR INSTALLATION

Install the generator in an area that is free of debris, bystanders, and overhead obstructions. Make sure the generator is on secure, level ground so that it cannot slide or shift around. Also, install the generator in a manner so that the exhaust will not be discharged in the direction of nearby homes.

The installation site must be relatively free from moisture and dust. All electrical equipment should be protected from excessive moisture. Failure to do so will result in deterioration of the insulation and will result in short circuits and grounding.

Foreign materials such as dust, sand, lint, and abrasive materials have a tendency to cause excessive wear to engine and alternator parts.

### CAUTION

Pay close attention to ventilation when operating the generator inside tunnels and caves. The engine exhaust contains noxious elements. Engine exhaust must be routed to a ventilated area.

## INDOOR INSTALLATION

Exhaust gases from diesel engines are extremely poisonous. Whenever an engine is installed indoors the exhaust fumes must be vented to the outside. The engine should be installed at least two feet from any outside wall. Using an exhaust pipe which is too long or too small can cause excessive back pressure which will cause the engine to heat excessively and possibly burn the valves.

## MOUNTING

The generator must be mounted on a solid foundation (such as concrete) and set firmly on the foundation to isolate vibration of the generator when it is running. The generator must be mounted at least 6 inches above the floor or grade level as referenced in the National Fire Protection Association handbook (NFPA 110, Chapter 7, Section 7.4).

**DO NOT** remove the metal skids on the bottom of the generator. They are to resist damage to the bottom of the generator and to maintain alignment.

# GENERAL INFORMATION

## GENERATOR

This generator (Figure 4) is designed as a high-quality, portable (requires a trailer for transport) power source for telecom sites, lighting facilities, power tools, submersible pumps and other industrial and construction machinery.

## OPERATING PANEL

The “Operating Panel” is provided with the following:

- ECU Controller with Gauge Unit Assembly
  - Oil Pressure Gauge
  - Water Temperature Gauge
  - Tachometer
  - Charging Voltmeter
  - Generator Load Gauge
  - Fuel Gauge
  - DEF Level Gauge
  - Check DEF Lamp
  - Emissions Failure Lamp
  - Exhaust Temp High Lamp
  - Regen Needed Lamp
  - Regen Inhibit Lamp
  - Low Fuel Alarm Lamp
- Panel Light/Panel Light Switch
- Engine Speed Switch
- Auto Start/Stop Switch
- Hour Check Button

## CONTROL PANEL

The “Control Panel” is provided with the following:

- Frequency Meter (Hz)
- AC Ammeter (Amps)
- AC Voltmeter (Volts)
- Ammeter Change-Over Switch
- Voltmeter Change-Over Switch
- Voltage Regulator
- 3-Pole, 200-Amp Main Circuit Breaker
- “Control Box” (located behind Control Panel)
  - Automatic Voltage Regulator
  - Current Transformer
  - Overcurrent Relay
  - Starter Relay

## OUTPUT TERMINAL PANEL

The “Output Terminal Panel” is provided with the following:

- Three 120/240V Output Receptacles (CS-6369), 50A
- Three Auxiliary Circuit Breakers, 50A
- Two 120V Output Receptacles (GFCI), 20A
- Two GFCI Circuit Breakers, 20A
- Five Output Terminal Lugs (3Ø power)
- Engine Block Heater
- Battery Charger (Option)
- Low Coolant Switch (Option)

## OPEN-DELTA EXCITATION SYSTEM

Each generator is equipped with the state-of-the-art “Open-Delta” excitation system. The open-delta system consists of an electrically independent winding wound among stationary windings of the AC output section.

There are four connections of the open delta—A, B, C and D. During steady-state loads, the power from the voltage regulator is supplied from the parallel connections of A to B, A to D, and C to D. These three phases of the voltage input to the voltage regulator are then rectified and are the excitation current for the exciter section.

When a heavy load such as a motor starting or a short circuit occurs, the automatic voltage regulator (AVR) switches the configuration of the open delta to the series connection of B to C. This has the effect of adding the voltages of each phase to provide higher excitation to the exciter section and thus better voltage response during the application of heavy loads.

The connections of the AVR to the AC output windings are for sensing only. No power is required from these windings.

The open-delta design provides virtually unlimited excitation current, offering maximum motor starting capabilities. The excitation does not have a “fixed ceiling” and responds according to the demands of the required load.

## ENGINE

This generator is powered by a 4-cylinder, 4-cycle, water-cooled, direct injection, turbocharged, EGR, DOC, SCR, John Deere 4045HFG04 diesel engine. This engine is designed to meet every performance requirement for the generator. Reference Table 2 for engine specifications.

In keeping with MQ Power’s policy of constantly improving its products, the specifications quoted herein are subject to change without prior notice.

## MICROPROCESSOR CONTROL SYSTEM

The microprocessor controls the RPMs of the engine. When the engine demand increases or decreases, the microprocessor system regulates the frequency variation to  $\pm 0.25\%$ .

## EXTENSION CABLES

When electric power is to be provided to various tools or loads at some distance from the generator, extension cords are normally used. Cables should be sized to allow for distance in length and amperage so that the voltage drop between the generator and point of use (load) is held to a minimum. Use the cable selection chart (Table 6) as a guide for selecting the proper extension cable size.

# MAJOR COMPONENTS

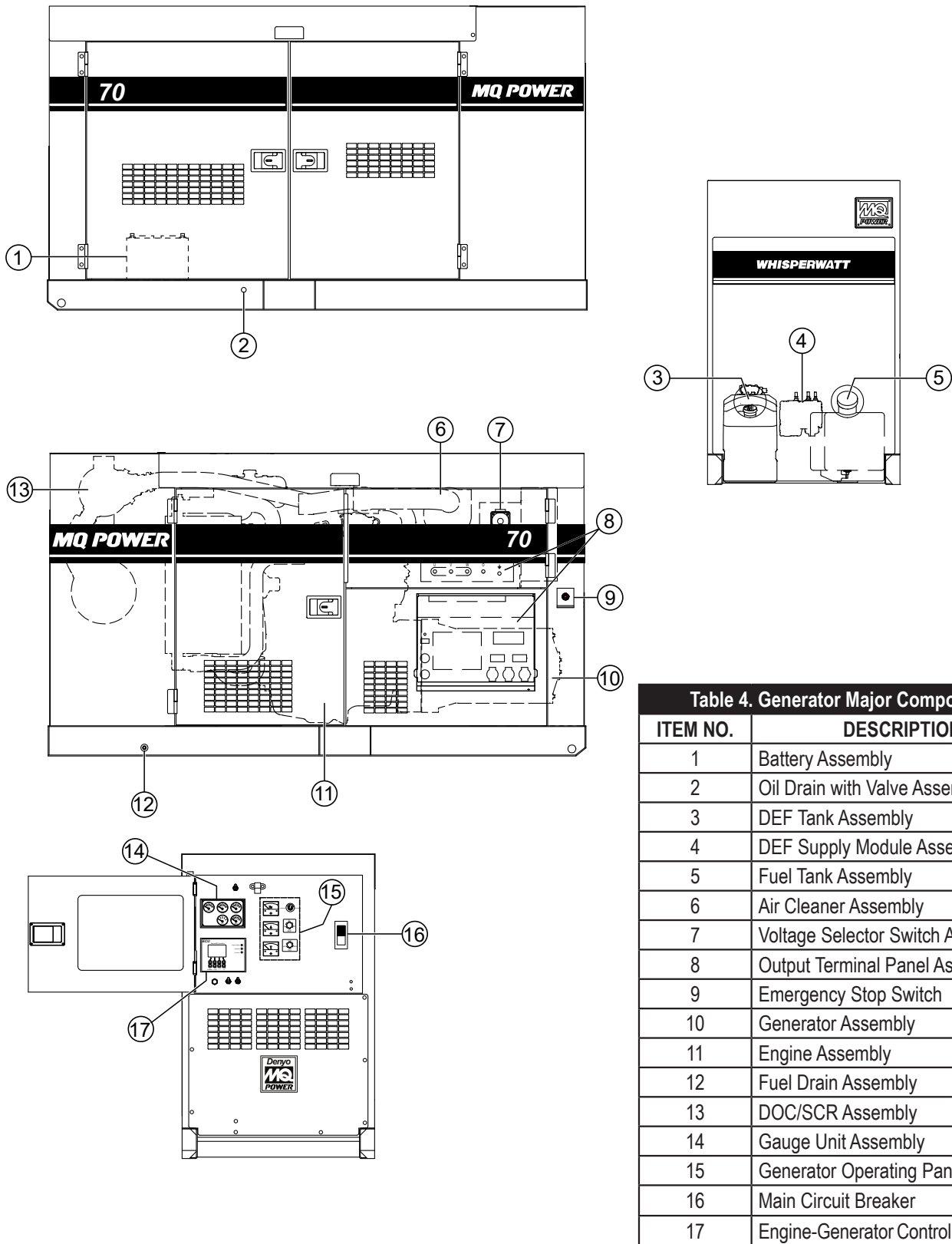
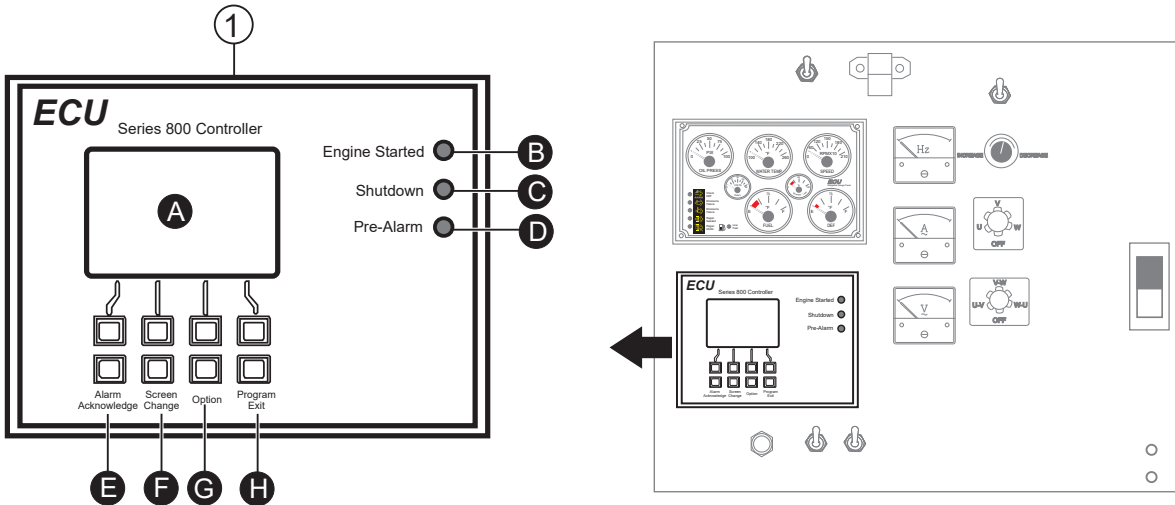

Figure 4. Major Components

# ENGINE CONTROL UNIT (ECU)



**Figure 5. Engine Control Unit (ECU)**

The definitions below describe the controls and functions of the Engine Control Unit (Figure 5).

1. **ECU Controller** — This engine-generator controller displays the parameters and the diagnostic troubleshooting messages of the engine.
  - A. **ECU Display Screen** — Engine fault diagnostic messages are shown on this LCD display screen.
  - B. **Engine Started Lamp** — This LED will light when the engine has started and is operating correctly
  - C. **Engine Shutdown Lamp** — When an engine failure has occurred this lamp will blink, indicating that the engine has been shut down. The diagnostic fault message will be displayed on the LCD screen.
  - D. **Pre-Alarm Lamp** — When an engine failure has occurred this lamp will blink, indicating a pre-fault engine condition and the possibility of engine shutdown. The diagnostic fault message will be displayed on the LCD screen.
  - E. **Alarm Acknowledge Button** — When the engine experiences a fault, the “Pre Alarm Lamp” or the “Shutdown Lamp” will start blinking. Pushing this button will confirm the fault message and the blinking lamp will change to a solid lamp display. The fault message will be displayed on the screen.

When multiple engine faults occur, the lamp will continue blinking until all fault messages are confirmed. The blinking lamp will change to a solid lamp display and all current confirmed fault messages will scroll across the screen.

- F. **Screen Change Button** — When this button is pushed during operation, the screen (Figure 6) will cycle through main and secondary parameter screens.

	VOLTS		AMPS
UO	139	UV 240	U 168
VO	139	VW 240	V 168
WO	139	WU 240	W 168
	56 kW		70 kVA
	60 Hz		105 h

**Figure 6. Generator Parameter Screen**

## NOTICE

The screen shown in Figure 6 represents the phase voltages for each phase to neutral (UO, VO and WO) and the line voltages between each phase (UV, VW and WU).

- G. **Option Button** — This button is not active. Do not use.
- H. **Program/Exit Button** — Push this button from the home screen to enter the main menu.

# ENGINE/GENERATOR CONTROL PANEL

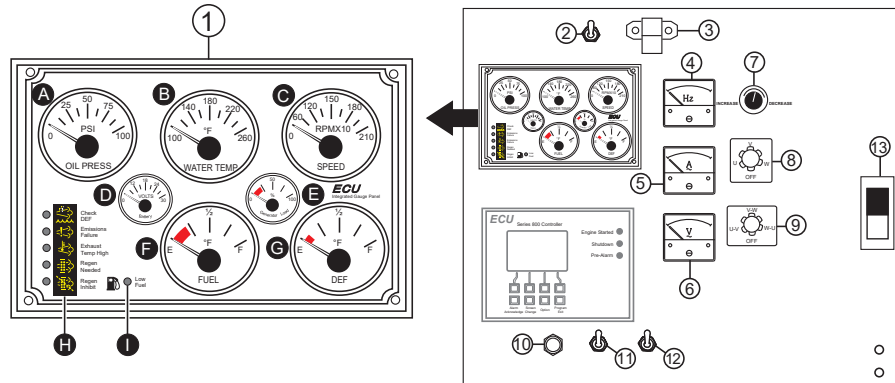

**Figure 7. Engine/Generator Control Panel**

The definitions below describe the controls and functions of the Engine/Generator Control Panel (Figure 7).

1. **Gauge Unit Assembly** — Houses the various engine monitoring gauges: oil pressure, water temperature, engine speed RPM (tachometer), fuel, DEF, charging voltmeter, and generator load.
  - A. **Oil Pressure Gauge** — During normal operation, this gauge should read approximately 39 psi (270 kPa). When starting the generator the oil pressure may read a little higher, but after the engine warms up the oil pressure should return to the correct pressure range.
  - B. **Water Temperature Gauge** — During normal operation this gauge should read between 185° and 207°F (85°–97°C).
  - C. **Tachometer** — Indicates engine speed in RPM for 60 Hz operation. This meter should indicate 1,800 rpm when the rated load is applied.
  - D. **Charging Voltmeter Gauge** — During normal operation this gauge indicates a minimum 14 VDC.
  - E. **Generator Load Gauge** — Indicates the generator load rate. It is recommended that the load be above the red area (20%) in order to maintain sufficient exhaust temperature.
  - F. **Fuel Gauge** — Indicates the amount of diesel fuel available. The red area on the gauge indicates low fuel (20%).
  - G. **DEF Level Gauge** — Indicates the DEF level in the tank. The red area on the gauge indicates low DEF level (10%).
  - H. **Exhaust System State Indicator Lamps** — Indicate the exhaust system state or DEF state.
  - I. **Low Fuel Warning Lamp** — Illuminates when the fuel level in the fuel tank is low.
2. **Panel Light Switch** — When activated will turn on the control panel light.
3. **Panel Light** — For operation at night, the panel light illuminates the control panel for ease of reading meters and gauges. Make sure the panel light switch is in the **OFF** position when the light is not in use.
4. **Frequency Meter** — Indicates the output frequency in hertz (Hz). Normally 60 Hz.
5. **AC Ammeter** — Indicates the amount of current the load is drawing from the generator per leg selected by the ammeter phase-selector switch.
6. **AC Voltmeter** — Indicates the output voltage present at the **U,V, and W** output terminal lugs.
7. **Voltage Regulator Control** — Allows ±15% manual adjustment of the generator's output voltage.
8. **Ammeter Change-Over Switch** — This switch allows the AC ammeter to indicate the current flowing to the load connected to any phase of the output terminals, or to be switched off. This switch does not affect the generator output in any fashion, it is for current reading only.
9. **Voltmeter Change-Over Switch** — This switch allows the AC voltmeter to indicate phase-to-phase voltage between any two phases of the output terminals or to be switched off.
10. **Hour Check Button** — With the engine stopped, press and hold this button. The total running hours, fuel level, battery voltage, and diagnostic trouble messages/codes will be displayed.
11. **Auto Start-Stop Switch** — This switch selects either manual or automatic operation. Center position is **OFF** (reset).
12. **Engine Speed Switch** — This switch controls the speed of the engine, low or high.
13. **Main Circuit Breaker** — This three-pole, 200-amp main breaker is provided to protect the **U,V, and W** output terminal lugs from overload.

# OUTPUT TERMINAL PANEL FAMILIARIZATION

## OUTPUT TERMINAL PANEL

The Output Terminal Panel (Figure 8) shown below is located on the right-hand side (left from the control panel) of the generator. Lift up on the cover to gain access to receptacles and terminal lugs.

### NOTICE

**Terminal O is neutral bonded to the ground from the factory.**

## OUTPUT TERMINAL FAMILIARIZATION

The “Output Terminal Panel” (Figure 8) is provided with the following:

- Three 240/120V Output Receptacles @ 50 amps
- Three Aux. Circuit Breakers @ 50 amps
- Two 120V GFCI Receptacles @ 20 amps
- Two GFCI Circuit Breakers @ 20 amps
- Five Output Terminal Lugs (U, V, W, O, Ground)

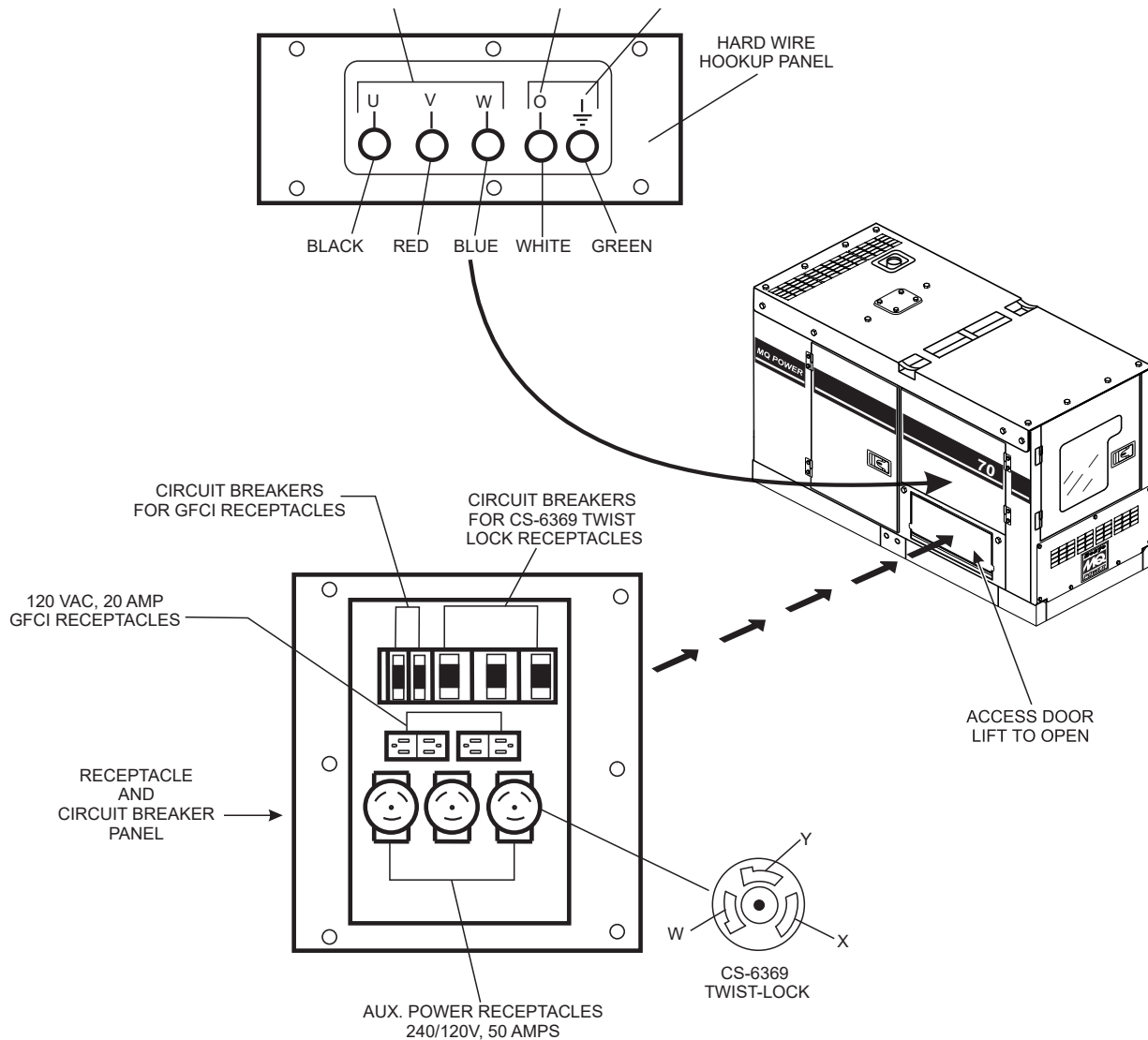

Figure 8. Output Terminal Panel

# OUTPUT TERMINAL PANEL FAMILIARIZATION

## 120 VAC GFCI Receptacles

### NOTICE

It is recommended that the GFCI receptacles be tested when the generator is initially uncrated. The receptacles should then be tested daily at startup.

There are two 120 VAC, 20-amp GFCI (Duplex NEMA 5-20R) receptacles provided on the output terminal panel. These receptacles can be accessed in any **voltage selector switch** position. Each receptacle is protected by a 20-amp circuit breaker. These breakers are located directly above the GFCI receptacles. Remember the load output (current) of both GFCI receptacles is dependent on the load requirements of the U, V, and W output terminal lugs.

Pressing the **reset** button resets the GFCI receptacle after being tripped. Pressing the **test button** (Figure 9) in the center of the receptacle will check the GFCI function. Both receptacles should be tested at least once a month. Reference the maintenance section in this manual for further testing of the GFCI receptacle.

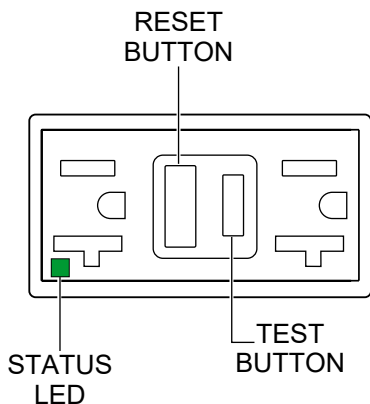

Figure 9. 120 VAC GFCI Receptacle

## Twist-Lock Dual-Voltage 240/120 VAC Receptacles

There are three 240/120V, 50-amp, auxiliary twist-lock (CS-6369) receptacles (Figure 10) provided on the output terminal panel. These receptacles can **only** be accessed when the voltage selector switch is placed in the **single-phase 240/120V** position.

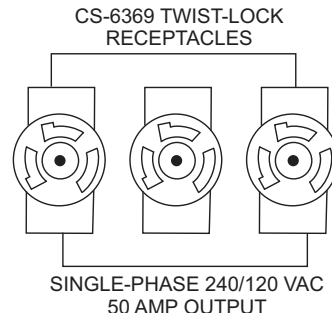

Figure 10. 240/120V Twist-Lock Auxiliary Receptacles

Each auxiliary receptacle is protected by a 50-amp circuit breaker. These breakers are located directly above the GFCI receptacles. Remember the load output (current) on both receptacles is dependent on the load requirements of the **output terminal lugs**.

## Removing the Plastic Face Plate (Hard Wire Hookup Panel)

The **Output Terminal Lugs** are protected by a plastic face plate cover (Figure 11). Unscrew the securing bolts and lift the plastic terminal cover to gain access to the terminal enclosure.

After the load wires have been securely attached to the terminal lugs, reinstall the plastic face plate.

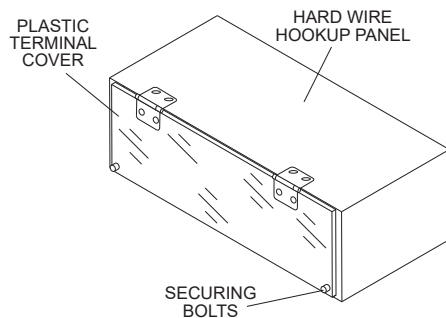

Figure 11. Plastic Face Plate (Output Terminal Lugs)

# OUTPUT TERMINAL PANEL FAMILIARIZATION

## Connecting Loads

Loads can be connected to the generator by the **Output Terminal Lugs** or the convenience receptacles (Figure 12). Make sure to read the operation manual before attempting to connect a load to the generator.

To protect the output terminals from overload, a 3-pole, 200-amp, **main** circuit breaker is provided. Make sure to switch **ALL** circuit breakers to the **OFF** position prior to starting the engine.

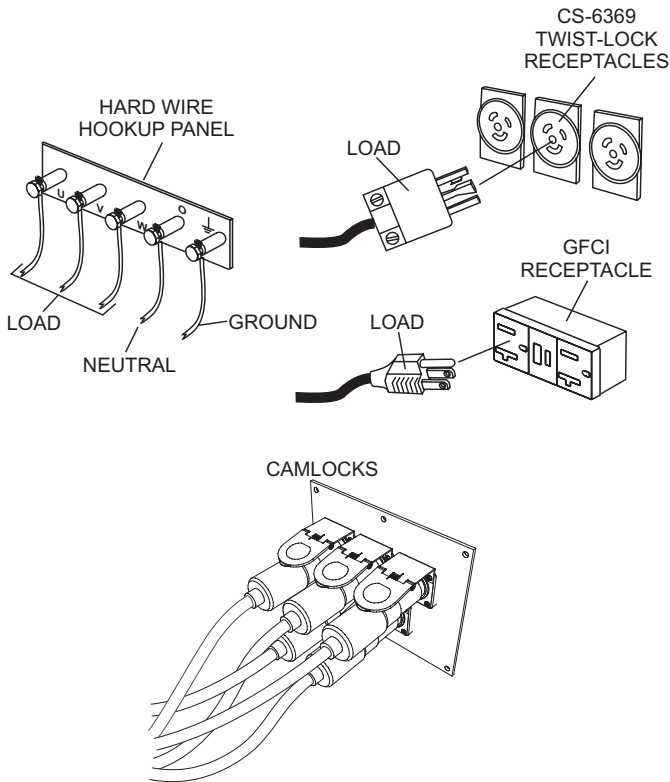

Figure 12. Connecting Loads

## Overcurrent Relay

An **overcurrent relay** (Figure 13) is connected to the main circuit breaker. In the event of an overload, both the circuit breaker and the overcurrent relay may trip. If the circuit breaker cannot be reset, the **reset button** on the overcurrent relay must be pressed. The overcurrent relay is located inside the control box.

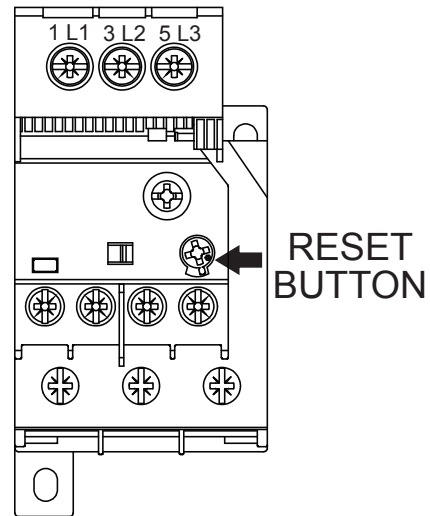

Figure 13. Overcurrent Relay

### NOTICE

Remember the **overcurrent relay** monitors the current flowing from the **U, V, and W Output Terminal Lugs** to the load.

In the event of a short circuit or overcurrent condition, it will automatically trip the 200-amp main breaker.

To restore power to the **Output Terminal Panel**, press the reset button on the overcurrent relay and place the **main** circuit breaker in the **closed** position (**ON**).

# LOAD APPLICATION

## SINGLE-PHASE LOAD

Always be sure to check the nameplate on the generator and equipment to ensure the wattage, amperage, frequency, and voltage requirements are satisfactorily supplied by the generator for operating the equipment.

Generally, the wattage listed on the nameplate of the equipment is its rated output. Equipment may require 130–150% more wattage than the rating on the nameplate, as the wattage is influenced by the efficiency, power factor and starting system of the equipment.

### NOTICE

If wattage is not given on the equipment's nameplate, approximate wattage may be determined by multiplying nameplate voltage by the nameplate amperage.

$$\text{WATTS} = \text{VOLTAGE} \times \text{AMPERAGE}$$

The power factor of this generator (single phase) is 1.0. See Table 5 below when connecting loads.

**Table 5. Power Factor By Load**

Type of Load	Power Factor
Single-phase induction motors	0.4–0.75
Electric heaters, incandescent lamps	1.0
Fluorescent lamps, mercury lamps	0.4–0.9
Electronic devices, communication equipment	1.0
Common power tools	0.8

**Table 6. Cable Selection (60 Hz, Single-Phase Operation)**

Current in Amperes	Load in Watts		Maximum Allowable Cable Length			
	At 120 Volts	At 240 Volts	#10 Wire	#12 Wire	#14 Wire	#16 Wire
2.5	300	600	1,000 ft.	600 ft.	375 ft.	250 ft.
5	600	1,200	500 ft.	300 ft.	200 ft.	125 ft.
7.5	900	1,800	350 ft.	200 ft.	125 ft.	100 ft.
10	1,200	2,400	250 ft.	150 ft.	100 ft.	
15	1,800	3,600	150 ft.	100 ft.	65 ft.	
20	2,400	4,800	125 ft.	75 ft.	50 ft.	

CAUTION: Equipment damage can result from low voltage.

### NOTICE

Cable selection table is a general guideline. **ALWAYS** consult local and national electrical codes when sizing cables.

## THREE-PHASE LOAD

When calculating the power requirements for 3-phase power use the following equation:

$$\text{KVA} = \frac{\text{VOLTAGE} \times \text{AMPERAGE} \times 1.732}{1000}$$

### NOTICE

If 3Ø load (kVA) is not given on the equipment nameplate, approximate 3Ø load may be determined by multiplying voltage by amperage by 1.732.

### NOTICE

Motors and motor-driven equipment draw much greater current for starting than during operation.

An inadequately sized connecting cable which cannot carry the required load can cause a voltage drop which can burn out the appliance or tool and overheat the cable. See Table 6.

The power factor of this generator (3 phase) is 0.8.

- When connecting a resistance load such as an incandescent lamp or electric heater, a capacity of up to the generating set's rated output (kW) can be used.
- When connecting a fluorescent or mercury lamp, a capacity of up to the generating set's rated output (kW) multiplied by 0.6 can be used.
- When connecting an electric drill or other power tools, pay close attention to the required starting current capacity.

When connecting ordinary power tools, a capacity of up to the generating set's rated output (kW) multiplied by 0.8 can be used.

### DANGER

Before connecting this generator to any building's electrical system, a **licensed electrician** must install an **isolation (transfer) switch**. Serious damage to the building's electrical system may occur without this transfer switch.

**PowerBalance®** (Figure 14) is an optional load management solution that helps protect the engine generator from problems resulting from sustained low-load operations (defined as less than 30% of the generator full-load rating).

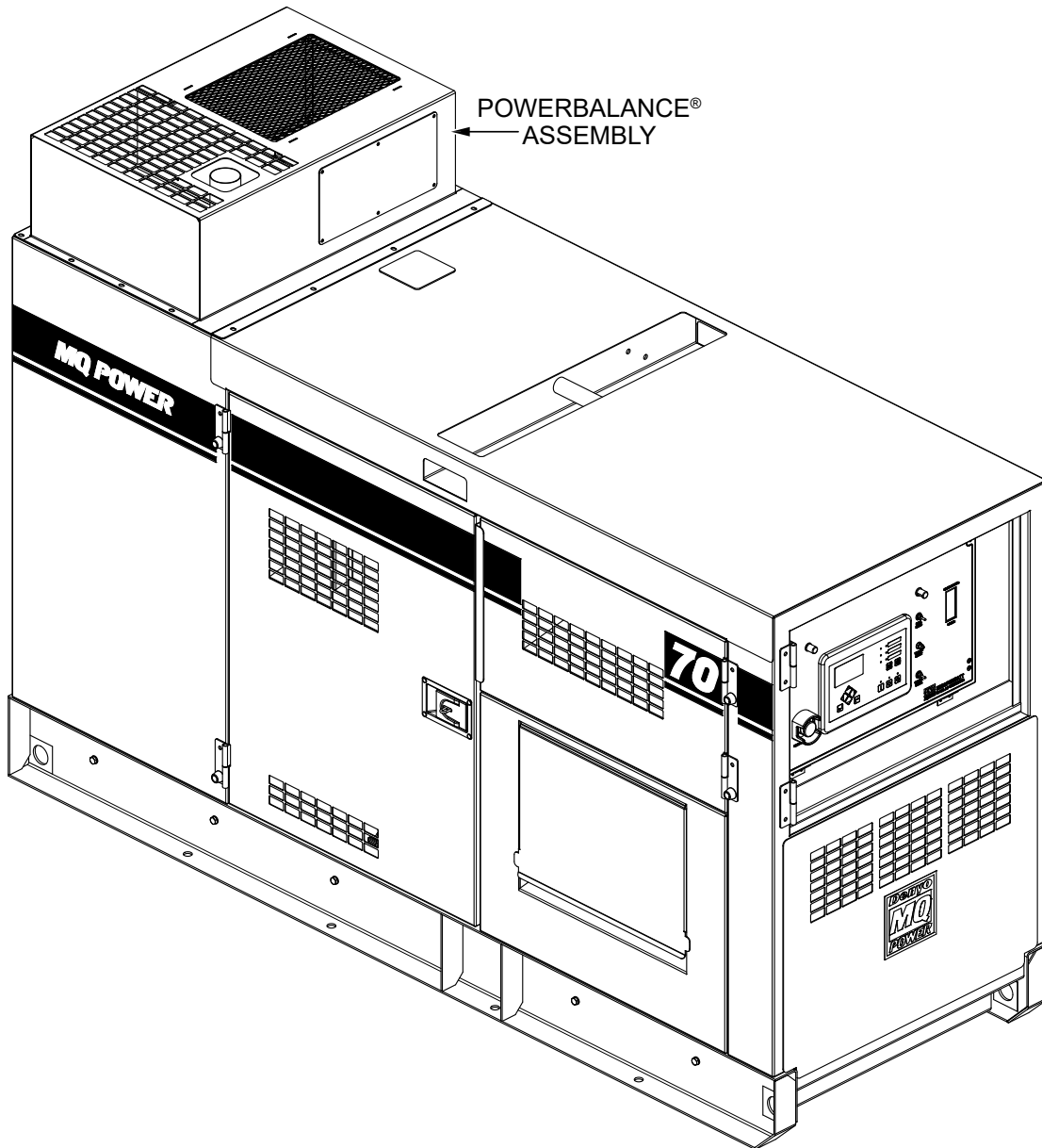

**Figure 14. PowerBalance®**

- PowerBalance® continuously monitors engine load. The load management controller senses and increases engine load automatically using resistive coils when the controller determines that the temperature and/or load is too low.
- When additional load demands are placed on the generator that bring it to an optimum level, PowerBalance® will automatically deactivate this additional load and remain ready for reactivation should exhaust temperatures drop.

# GENERATOR OUTPUTS

## GENERATOR OUTPUT VOLTAGES

A wide range of voltages (Table 7) is available for many different applications.

Table 7. Voltages Available						
UVWO Output Terminal Lugs	Voltage Selector Switch 3-Phase 240/139V Position			Voltage Selector Switch 3-Phase 480/277V Position		
	3Ø Line-Line	208V	220V	240V	416V	440V
1Ø Line-Neutral	120V	127V	139V	240V	254V	277V
Voltage Selector Switch Single-Phase 240/120V Position						
1Ø Line-Neutral/ Line-Line	120V Line-Neutral	N/A	N/A	240V Line-Line	N/A	N/A

### Voltage Selector Switch

Voltages are selected using the Voltage Selector switch (Figure 15) which is located above the output terminal panel's hard wire hook-up panel. This switch has been provided for ease of voltage selection.

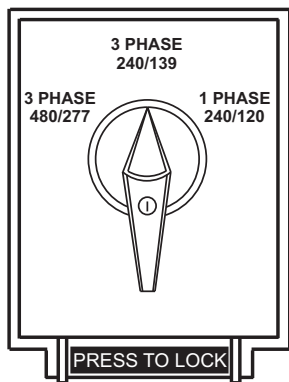

Figure 15. Voltage Selector Switch

**CAUTION**

**NEVER** change the position of the **voltage selector switch** while the engine is running. **ALWAYS** place the circuit breaker in the **OFF** position before selecting voltage.

### Voltage Regulator

To obtain some of the voltages listed in Table 7 will require a fine voltage adjustment using the voltage regulator (Figure 16) located on the control panel.

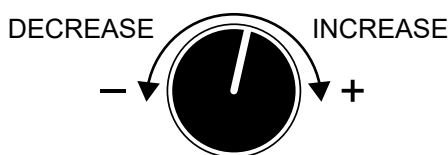

Figure 16. Voltage Regulator

## Maximum Amps

Table 8 shows the **maximum** amps the generator can provide. **DO NOT** exceed the maximum amps as listed.

Table 8. Generator Maximum Amps	
Rated Voltage	Maximum Amps
1Ø 120 volts	168 amps × 2 (zigzag)
1Ø 240 volts	168 amps (zigzag)
3Ø 240 volts	168 amps
3Ø 480 volts	84 amps
Main Line Circuit Breaker Rating	200 amps

## GFCI Receptacle Load Capability

The load capability of the GFCI receptacles is directly related to the voltage being supplied at either the output terminals or the three twist-lock auxiliary receptacles.

Table 9 and Table 10 show what amount of current is available at the GFCI receptacles when the output terminals and twist-lock receptacles are in use. Be careful that your load does not exceed the available current capability at the receptacles.

Table 9. 1Ø GFCI Receptacle Load Capacity	
kW in Use Twist Lock (CS6369)	Available Load Current (Amps)
1Ø 240/120V	GFCI Duplex 5-20R 120V
40.4	0
39.2	5 amps/receptacle
38.0	10 amps/receptacle
36.8	15 amps/receptacle
35.6	20 amps/receptacle

Table 10. 3Ø Generator Maximum Amps	
kVA in Use (UVWO Terminals)	Available Load Current (Amps)
3Ø 240/480V	GFCI Duplex 5-20R 120V
70.0	0 amps/receptacle
65.8	5 amps/receptacle
61.7	10 amps/receptacle
57.5	15 amps/receptacle
53.3	20 amps/receptacle

## HOW TO READ THE AC AMMETER AND AC VOLTMETER GAUGES

The AC ammeter and AC voltmeter gauges are controlled by the AC ammeter and AC voltmeter change-over switches.

Both of these switches are located on the control panel and **DO NOT** affect the generator output. They are provided to help observe how much power is being produced at the UVWO terminal lugs.

Before taking a reading from either gauge, set the **Voltage Selector Switch** (Figure 17) to the position which produces the required voltage. For example, for 3Ø 240V, choose the center 3Ø 240/139V position on the voltage selector switch.

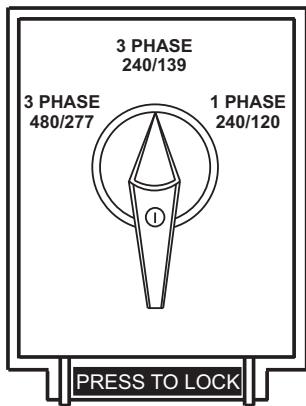

Figure 17. Voltage Selector Switch  
240/3Ø Position

## AC Voltmeter Gauge Reading

Place the **AC Voltmeter Change-Over Switch** (Figure 18) in the W-U position and observe the phase-to-phase voltage reading between the W and U terminals as indicated on the **AC Voltmeter Gauge** (Figure 19).

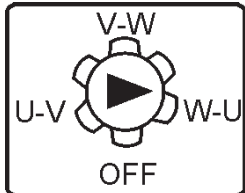

Figure 18. AC Voltmeter  
Change-Over Switch

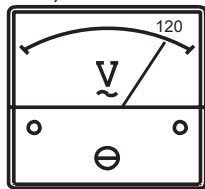

Figure 19. AC Voltmeter Gauge  
(Volt Reading On W-U Lug)

## AC Ammeter Gauge Reading

Place the **AC Ammeter Change-Over Switch** (Figure 20) in the U position and observe the current reading (load drain) on the U terminal as indicated on the **AC Ammeter Gauge** (Figure 21). This process can be repeated for terminals V and W.

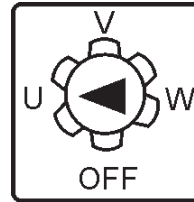

Figure 20. AC Ammeter  
Change-Over Switch

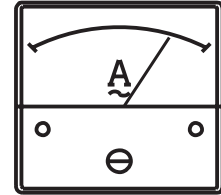

Figure 21. AC Ammeter  
(Amp Reading On U Lug)

### NOTICE

The **ammeter** gauge will only show a reading when the **Output Terminal Lugs** are connected to a load and in use.

# OUTPUT TERMINAL PANEL CONNECTIONS

## UVWO TERMINAL OUTPUT VOLTAGES

Various output voltages can be obtained using the UVWO output terminal lugs. The voltages at the terminals are dependent on the position of the **Voltage Selector Switch** and the adjustment of the **Voltage Regulator Control Knob**.

Remember the voltage selector switch determines the **range** of the output voltage. The voltage regulator (VR) allows the user to increase or decrease the selected voltage.

### 3Ø-240V UVWO Terminal Output Voltages

1. Place the voltage selector switch in the 3Ø 240/139 position as shown in Figure 22.

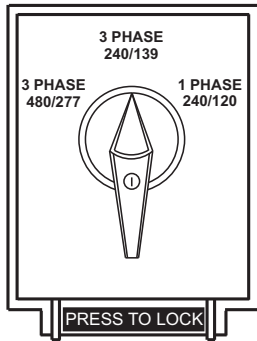

**Figure 22. Voltage Selector Switch  
3Ø-240/139V Position**

2. Connect the load wires to the UVWO terminals as shown in Figure 23.

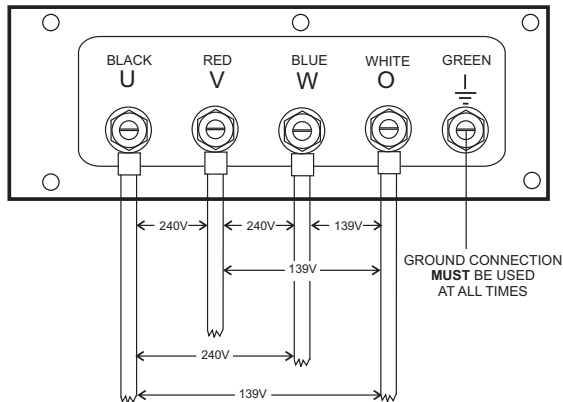

**Figure 23. UVWO Terminal Lugs  
(3-Phase 240-Volt Connections)**

3. Turn the voltage regulator (Figure 24) clockwise to increase voltage output, and turn counterclockwise to decrease voltage output. Use the voltage regulator whenever fine tuning of the output voltage is required.

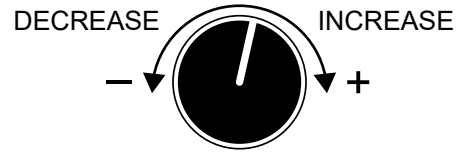

**Figure 24. Voltage Regulator**

### 3Ø-208V/1Ø-120V UVWO Terminal Output Voltages

1. Place the voltage selector switch in the 3Ø 240/139 position as shown in Figure 22.
2. Connect the load wires to the UVWO terminals as shown in Figure 25.

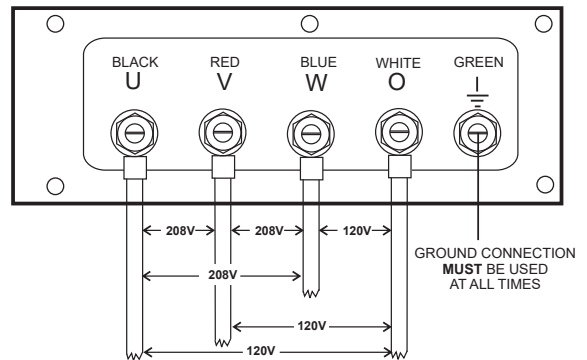

**Figure 25. UVWO Terminal Lugs  
3Ø-208/1Ø-120V Connections**

#### NOTICE

To achieve a 3Ø 208V output the voltage selector switch must be in the 3Ø-240/139 position and the voltage regulator must be adjusted to 208V.

# OUTPUT TERMINAL PANEL CONNECTIONS

## 3Ø-480/277V UVWO Terminal Output Voltages

1. Place the voltage selector switch in the 3Ø 480/277 position as shown in Figure 26.

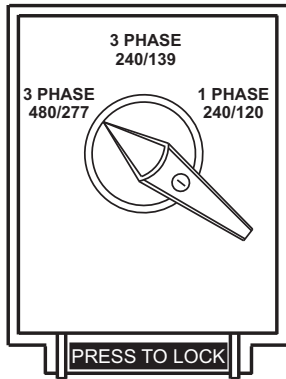

**Figure 26. Voltage Selector Switch  
3Ø-480/277V Position**

2. Connect the load wires to the UVWO terminals as shown in Figure 27.

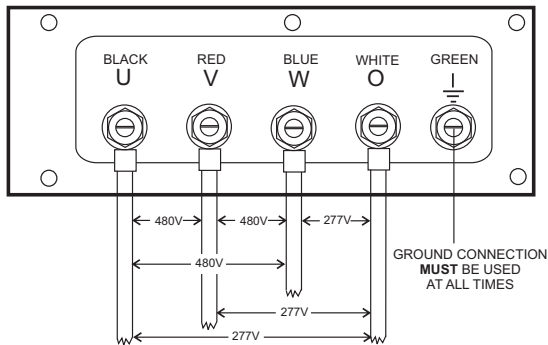

**Figure 27. UVWO Terminal Lugs 3Ø-480V  
Connections**

### NOTICE

**ALWAYS** make sure that the connections to the UVWO terminals are **secure** and **tight**. The possibility of arcing exists, that could cause a fire.

## 1Ø-240/120V UVWO Terminal Output Voltages

1. Place the voltage selector switch in the 1Ø 240/120 position as shown in Figure 28.

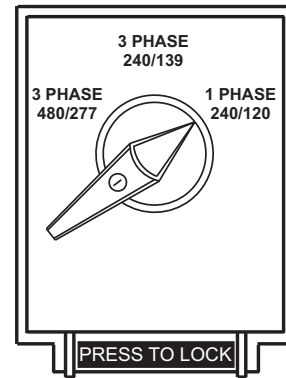

**Figure 28. Voltage Selector Switch  
1Ø-240/120V Position**

2. Connect the load wires to the UVWO terminals as shown in Figure 29.

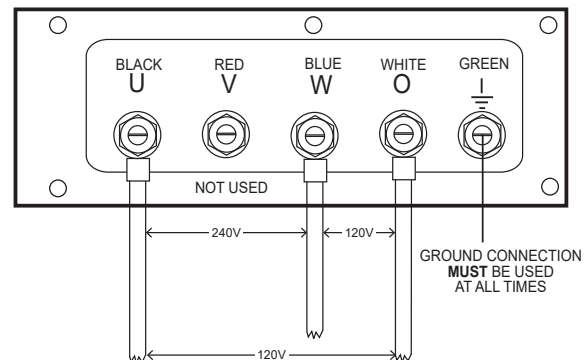

**Figure 29. UVWO Terminal Lugs  
1Ø-240/120V Connection**

3. Turn the voltage regulator (Figure 24) clockwise to increase voltage output, or counterclockwise to decrease voltage output. Use the voltage regulator whenever fine tuning of the output voltage is required.

## ENGINE OIL CHECK

1. To check the engine oil level, place the generator on secure, level ground with the engine stopped.
2. Remove the dipstick from its holder (Figure 30) and wipe it clean.

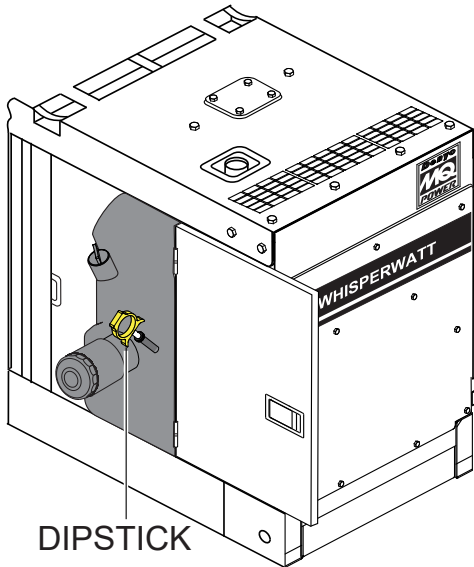

Figure 30. Engine Oil Dipstick

3. Reinsert the dipstick, then remove the dipstick from its holder. Check the oil level shown on the dipstick (Figure 31).

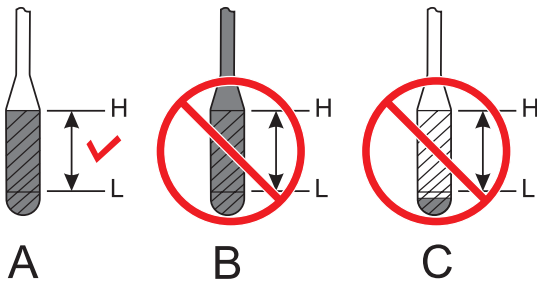

Figure 31. Engine Oil Dipstick

4. Verify that the engine oil level is maintained between the H and L markings on the dipstick as referenced in Figure 31A.
5. If the engine oil level is low (Figure 31C), remove the cap from the oil filler port (Figure 32) and fill to a safe operating level (max) as indicated by the dipstick (Figure 31A). Fill with recommended type oil as listed in Table 11. Maximum oil capacity is 3.88 gallons (14.7 liters).

### NOTICE

When adding engine oil **DO NOT** overfill (Figure 31B).

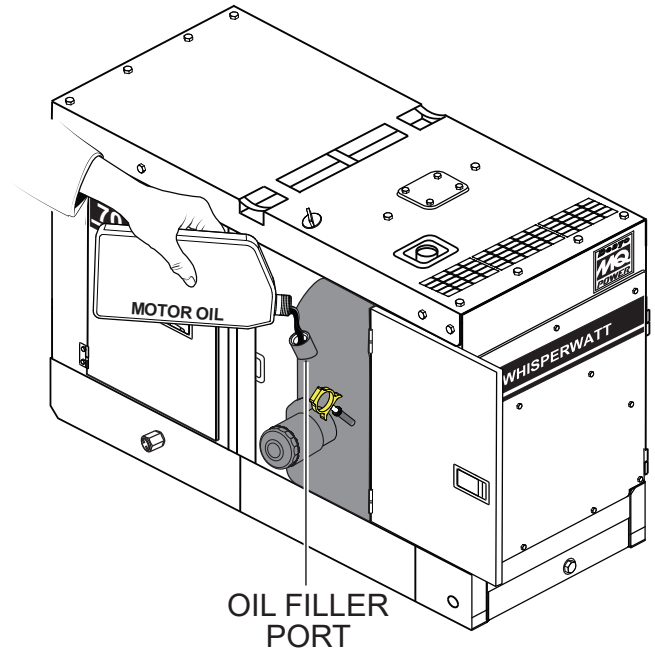

Figure 32. Engine Oil Filler Port

6. When checking the engine oil, be sure to check if the oil is clean. If the oil is not clean, drain the oil as described in the Maintenance section of this manual.
7. Allow enough time for any added oil to make its way to the oil pan before rechecking.

Table 11. Recommended Motor Oil

SAE 30	
SAE 20, 20W	
SAE 10W	
SAE 10W-30	
SAE 40	
SAE 5W-40, 20W-40	
SAE 5W-20	
-20	100°F
-30	40°C

## FUEL CHECK

### **! DANGER**



Fuel spillage on a **hot** engine can cause a **fire** or **explosion**. If fuel spillage occurs, wipe up the spilled fuel completely to prevent fire hazards. **NEVER** smoke around or near the generator. **ALWAYS** shut down the engine prior to cleaning up any spilled fuel.

### NOTICE

**ALWAYS** check the DEF tank level when adding fuel.

## Refilling The Fuel System

### NOTICE

**DO NOT** refuel while the engine is running.

### **! CAUTION**

**ONLY** properly trained personnel who have read and understand this section should refill the fuel tank system.

**ALWAYS** fill the fuel tank (Figure 33) with clean, fresh #2 diesel fuel. **DO NOT** fill the fuel tank beyond its capacity.

Pay attention to the fuel tank capacity when replenishing fuel. The fuel tank cap must be closed tightly after filling. Handle fuel in a safety container. If the container does not have a spout, use a funnel. Wipe up any spilled fuel immediately.

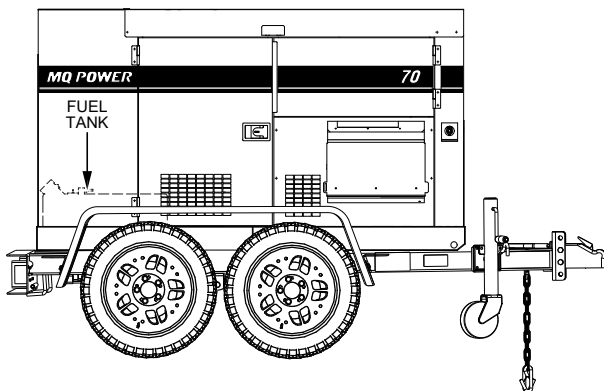

Figure 33. Fuel Tank

## Refueling Procedure

### **! WARNING**



**Diesel fuel** and its vapors are dangerous to your health and the surrounding environment. Avoid skin contact and/or inhaling fumes.

1. **Level Tanks** — Make sure fuel cells are level with the ground. Failure to do so will cause fuel to spill from the tank before reaching full capacity (Figure 34).

### **! CAUTION**

**ALWAYS** place the trailer on firm, level ground before refueling to prevent spilling and maximize the amount of fuel that can be pumped into the tank.

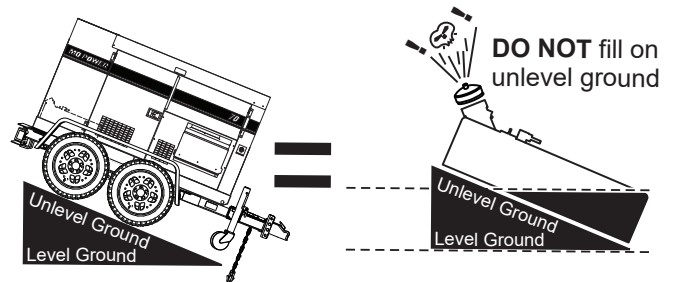

Figure 34. Only Fill On Level Ground

### NOTICE

**ONLY** use #2 diesel fuel when refueling.

2. Remove the fuel cap and fill the tank as shown in Figure 35.

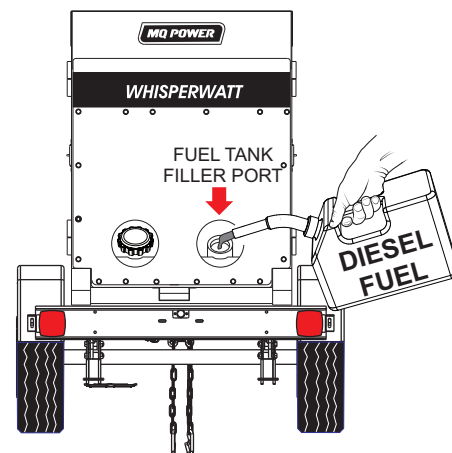

Figure 35. Fueling The Generator

3. **NEVER overfill the fuel tank** — It is important to read the fuel gauge when filling the trailer fuel tank. **DO NOT** wait for fuel to rise in the filler neck (Figure 36).

FUEL GAUGE LOCATED  
ON GAUGE UNIT ASSEMBLY

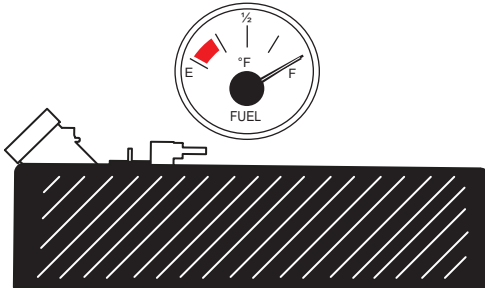

Figure 36. Full Fuel Tank

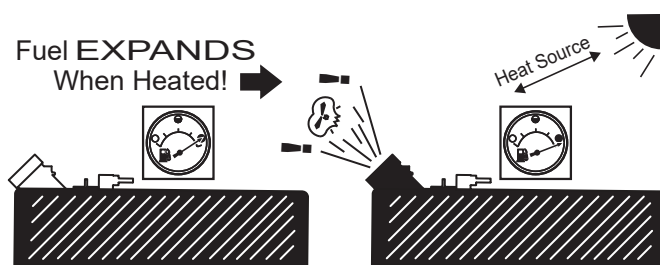
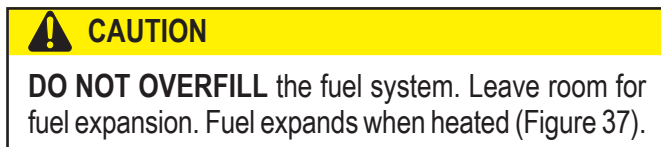

Figure 37. Fuel Expansion

## DIESEL EXHAUST FLUID

### NOTICE

**ONLY** fill the DEF tank with **diesel exhaust fluid**. Any other type of fluid may cause severe engine damage.

**Diesel exhaust fluid** is an aqueous solution made with 32.5% high-purity **urea** (carbamide) and 67.5% **deionized water**. DEF is used as a consumable in **selective catalytic reduction** (SCR) in order to lower NO<sub>x</sub> concentration from diesel exhaust emissions.

1. Make sure the engine is **OFF**.
2. Remove the filler cap from the DEF tank (Figure 38).

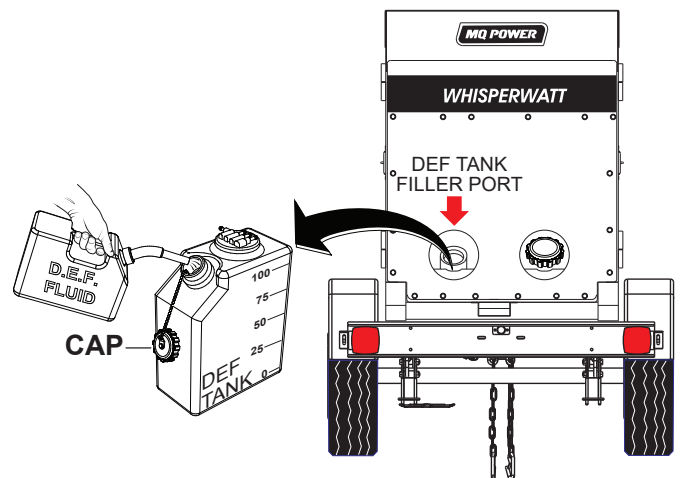

Figure 38. DEF Tank Filling

3. Add diesel exhaust fluid to the tank. **DO NOT** overfill.

### DEF Refilling (Continuous Operation)

It is recommended to **shut down the engine** prior to refilling the DEF tank. However, in special applications where shutdown is not possible, it is recommended to **ONLY** refill the DEF tank when the fluid level has been consumed down to 50%.

The DEF level sending unit requires a gradual DEF level decrease during continuous operation to validate proper operation. Failure of this sensor to report the decrease could result in an engine shutdown. An engine service technician would be required to remedy the shutdown.

## COOLANT (ANTIFREEZE/SUMMER COOLANT/WATER)

John Deere recommends antifreeze/summer coolant for use in their engines, which can be purchased in concentrate (and mixed with 50% demineralized water) or pre-diluted. See the **John Deere Engine Owner's Manual** for further details.

**WARNING**



If adding coolant/antifreeze mix to the radiator, **DO NOT** remove the radiator cap until the unit has completely cooled. The possibility of **hot!** coolant exists which can cause severe burns.

Day-to-day addition of coolant is done from the reserve tank. When adding coolant to the radiator, **DO NOT** remove the radiator cap until the unit has completely cooled. See Table 12 for engine, radiator, and reserve tank coolant capacities.

Table 12. Coolant Capacity	
Engine and Radiator	6.3 gal. (23.7 liters)
Reserve Tank	1.59 gal. (6.0 liters)

**NOTICE**

Normally, only the coolant level in the reserve tank needs to be checked. However, the radiator cap should be opened once a week to verify that coolant is visible (full) inside the radiator.

1. Verify that the coolant level in the coolant reserve tank is between the **MIN** and **MAX** markings as shown in Figure 39.

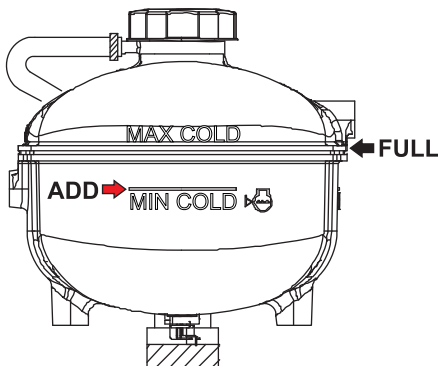

Figure 39. Coolant Reserve Tank

## Operation In Freezing Weather

When operating in freezing weather, be certain the proper amount of antifreeze (Table 13) has been added.

Table 13. Coolant Concentration		
Climate	Outside Temperature	Long-Life Coolant Concentration
Warm	10°F (-12°C) or Above	30%
Cold	-22°F (-30°C) or Above	50%

## Cleaning The Radiator

The engine may overheat if the radiator cooling fins (Figure 40) become overloaded with dust or debris. Periodically clean the radiator fins with compressed air. Cleaning inside the machine is dangerous, so clean only with the engine turned off and the **negative** battery terminal disconnected.

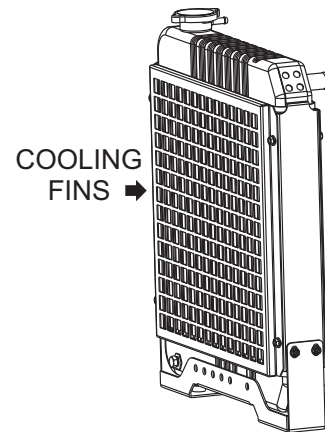

Figure 40. Radiator (Cooling Fins)

## ENGINE AIR CLEANER

Periodic cleaning/replacement of the air cleaner is necessary. Inspect the air cleaner (Figure 41) in accordance with the maintenance section of this manual or the **John Deere Engine Owner's Manual**.

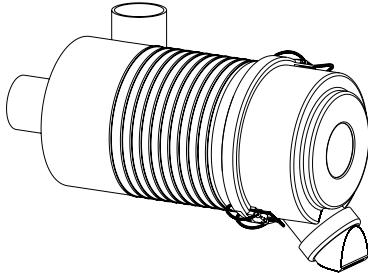

Figure 41. Air Cleaner

## FAN BELT TENSION

The engine fan belt is automatically tensioned and does not require adjustment.

### CAUTION



**NEVER** place hands near the belts or fan while the generator set is running.

## BATTERY

This unit is of negative ground. **DO NOT** connect in reverse. Always maintain battery fluid level between the specified marks. Battery life will be shortened if the fluid levels are not properly maintained. Add only distilled water when replenishment is necessary.

**DO NOT** overfill. Check to see whether the battery cables are loose. Poor contact may result in poor starting or malfunctions. **ALWAYS** keep the terminals firmly tightened. Coat the terminals with an approved battery terminal treatment compound. Replace the battery with only the recommended type battery. The battery type used in this generator is BCI Group 27.

The battery is sufficiently charged if the specific gravity of the battery fluid is 1.28 (at 68°F). If the specific gravity should fall to 1.245 or lower, it indicates that the battery is dead and needs to be recharged or replaced.

Before charging the battery with an external electric source, be sure to disconnect the battery cables.

## Battery Cable Installation

**ALWAYS** be sure the battery cables (Figure 42) are properly connected to the battery terminals as shown below. The **red cable** is connected to the positive terminal of the battery, and the **black cable** is connected to the negative terminal of the battery.

### CAUTION

**ALWAYS** disconnect the negative terminal **FIRST** and reconnect the negative terminal **LAST**.

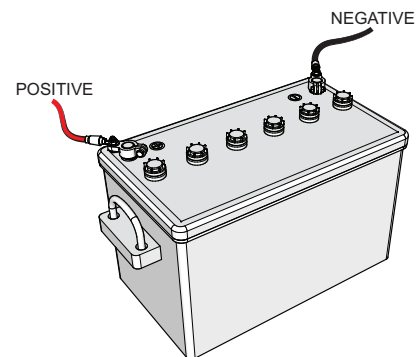

Figure 42. Battery Connections

When connecting the battery do the following:

1. **NEVER** connect the battery cables to the battery terminals when the **Auto Start/Stop Switch** is in either the **AUTO** or **MANUAL** position. **ALWAYS** make sure that this switch is in the **OFF/RESET** position when connecting the battery.
2. Place a small amount of battery terminal treatment compound around both battery terminals. This will ensure a good connection and will help prevent corrosion around the battery terminals.

### NOTICE

If the battery cable is connected incorrectly, electrical damage to the generator will occur. Pay close attention to the polarity of the battery when connecting the battery.

### CAUTION

Inadequate battery connections may cause poor starting of the generator, and create other malfunctions.

## ALTERNATOR

The polarity of the alternator is negative grounding type. When an inverted circuit connection takes place, the circuit will be in short circuit instantaneously, resulting in alternator failure.

**DO NOT** put water directly on the alternator. Entry of water into the alternator can cause corrosion and damage the alternator.

## WIRING

Inspect the entire generator for bad or worn electrical wiring or connections. If any wiring or connections are exposed (insulation missing) replace wiring immediately.

## PIPING AND HOSE CONNECTIONS

Inspect all piping, oil hose, and fuel hose connections for wear and tightness. Tighten all hose clamps and check hoses for leaks.

If any fuel or oil hose lines are defective, replace them immediately.

# GENERATOR START-UP PROCEDURE (MANUAL)

## BEFORE STARTING

### CAUTION

The engine's exhaust contains harmful emissions. **ALWAYS** have adequate ventilation when operating. Direct exhaust away from nearby personnel.

### WARNING

**NEVER** manually start the engine with the **main, GFCI or auxiliary** circuit breakers in the **ON** (closed) position.

- Place the **main, GFCI, and aux.** circuit breakers (Figure 43) in the **OFF** position prior to starting the engine.

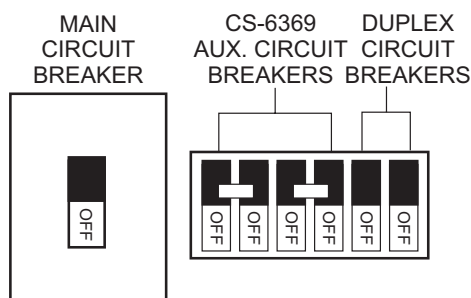

**Figure 43. Main, Aux. and GFCI Circuit Breakers (OFF)**

- Make sure the **voltage selector switch** has been configured for the desired output voltage.
- Connect the load to the **receptacles** or the **output terminal lugs** as shown in Figure 12. These load connection points can be found on the output terminal panel and the output terminal panel's hard wire hookup panel.
- Tighten terminal nuts securely to prevent load wires from slipping out.
- Close all engine enclosure doors (Figure 44).

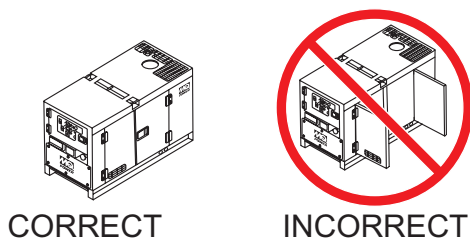

**Figure 44. Engine Enclosure Doors**

## STARTING (MANUAL)

- Place the **Auto Start/Stop Switch** in the **MANUAL** position to start the engine (Figure 45).



**Figure 45. Auto Start/Stop Switch (Manual Position)**

### NOTICE

If the engine fails to start within a specified number of attempts, the shutdown lamp will illuminate and the Auto Start/Stop Switch must be placed in the Off/Reset position before the engine can be restarted.

### NOTICE

The engine will pre-heat automatically in cold weather conditions. "Glow Plug Hold" message will be displayed and the engine will start automatically after pre-heating.

- Once the engine starts, let the engine run for 1–2 minutes (let the engine idle longer in cold weather conditions). Listen for any abnormal noises. If any abnormalities exist, shut down the engine and correct the problem.
- The generator's frequency meter (Figure 46) should be displaying the 60-cycle output frequency in **HERTZ**.

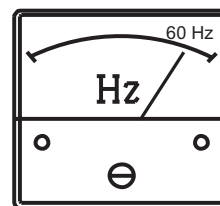

**Figure 46. Frequency Meter**

- The generator's AC voltmeter (Figure 47) will display the generator's output in **VOLTS**.

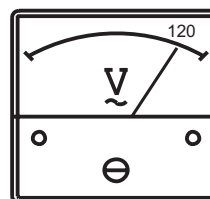

**Figure 47. Voltmeter**

# GENERATOR START-UP PROCEDURE (MANUAL)

5. If the voltage is not within the specified tolerance, use the voltage regulator (Figure 48) to increase or decrease the desired voltage.



Figure 48. Voltage Regulator

6. The **ammeter** (Figure 49) will indicate **zero amps** with no load applied. When a load is applied, the ammeter will indicate the amount of current that the load is drawing from the generator.

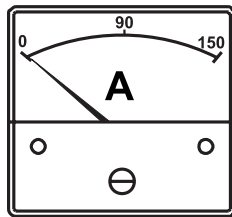

Figure 49. Ammeter (No Load)

7. The **engine oil pressure gauge** (Figure 50) will indicate the oil pressure of the engine. Under normal operating conditions the oil pressure should be approximately 39 psi (270 kPa).

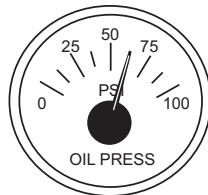

Figure 50. Oil Pressure Gauge

8. The **coolant temperature gauge** (Figure 51) will indicate the coolant temperature. Under normal operating conditions the coolant temperature should be between 185°–207°F (85°–97°C) (**Green Zone**).

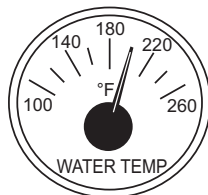

Figure 51. Coolant Temperature Gauge

9. The **tachometer gauge** (Figure 52) will indicate the speed of the engine when the generator is operating. Under normal operating conditions this speed is approximately 1,800 rpm.

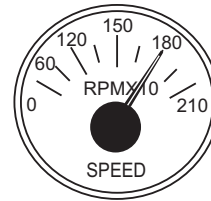

Figure 52. Engine Tachometer Gauge

10. Place the **main, GFCI, and aux.** circuit breakers in the **ON** position (Figure 53).

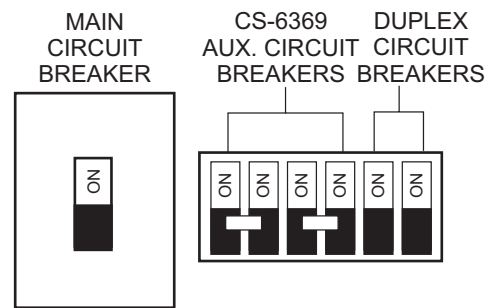

Figure 53. Main, Aux. and GFCI Circuit Breakers (ON)

11. Observe the generator's ammeter (Figure 54) and verify it reads the anticipated amount of current with respect to the load. The ammeter will only display a current reading if a load is in use.

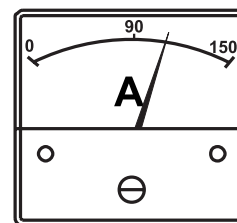

Figure 54. Ammeter (Load)

12. The generator will run until manually stopped or an abnormal condition occurs.

# GENERATOR START-UP PROCEDURE (AUTO MODE)

## STARTING (AUTO MODE)

### DANGER



Before connecting this generator to any building's electrical system, a **licensed electrician** must install an **isolation (transfer) switch**. Serious damage to the building's electrical system may occur without this transfer switch.

### CAUTION

When connecting the generator to an isolation (transfer) switch, **ALWAYS** have power applied to the generator's internal battery charger. This will ensure that the engine will not fail due to a dead battery.

### NOTICE

When the generator is set in **AUTO** mode, the generator will **automatically start** in the event of commercial power falling below a prescribed level by means of a contact closure that is generated automatically by a transfer switch.

### WARNING

When running the generator in **AUTO** mode, remember the generator can start up at any time without warning. **NEVER** attempt to perform any maintenance when the generator is in auto mode.

### CAUTION

The engine speed switch **must** be set to the "High" position when running in the **auto-start** mode. Failing to set the switch to the proper position can result in damage to your generator when it turns on.

### NOTICE

When the **Auto Start/Stop switch** is placed in the **AUTO** position, the engine glow plugs will be warmed and the engine will start automatically.

When starting the generator in **AUTO** mode use the "Manual Start-Up" procedure except where noted (see below).

1. Perform steps 1 through 5 in the Before Starting section as outlined in the Manual Starting Procedure.
2. Place the **Auto Start/Stop Switch** (Figure 55) in the **AUTO** position.



**Figure 55. Auto Start/Stop Switch (AUTO)**

3. Continue operating the generator as outlined in the Manual Start-Up procedure (start at step 3).

# GENERATOR SHUTDOWN PROCEDURE

## WARNING

**NEVER** stop the engine suddenly except in an emergency.

## NORMAL SHUTDOWN PROCEDURE

To shut down the generator, use the following procedure:

1. Place the **MAIN, GFCI, and LOAD** circuit breakers as shown in Figure 56 to the **OFF** position.

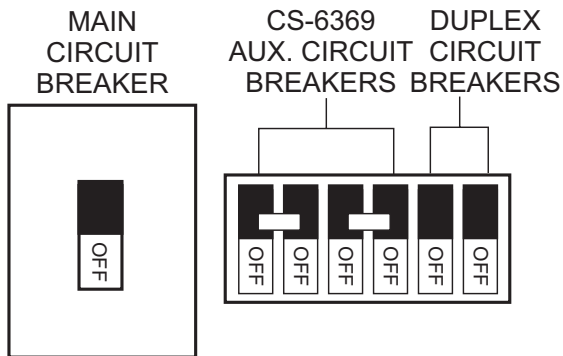

**Figure 56. Main, Aux. and GFCI Circuit Breakers (OFF)**

2. Let the engine cool by running it at low speed for 3–5 minutes with no load applied.
3. Place the **Auto Start/Stop switch** (Figure 57) in the **OFF/RESET** position.



**Figure 57. Auto Start/Stop Switch (Off/Reset)**

4. Verify that all status LEDs on the ECU control panel are **OFF** (not lit).
5. Remove all loads from the generator.
6. Inspect the entire generator for any damage or loosening of components that may have occurred during operation.

## EMERGENCY SHUTDOWN PROCEDURE

### NOTICE

The Emergency Stop switch should only be used to stop the engine in case of an emergency or to lock out operation during service. The emergency stop switch should **NEVER** be used for routine stopping of the engine.

1. To stop the engine in the event of an emergency, push the **Emergency Stop switch** (Figure 58).

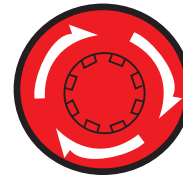

**Figure 58. Emergency Stop Switch**

2. The emergency stop switch is a push-locked type switch. The switch contact can only be released by rotating the button in the clockwise direction. The engine can not be restarted until the contact is released (**closed**).
3. Place the **MAIN, GFCI, and LOAD** circuit breakers in the **OFF** position as shown in Figure 56.

## AUTOMATIC SHUTDOWN SYSTEM

This unit is equipped with safety devices to automatically stop the engine in the event of low oil pressure, approximately 17 psi (117 kPa), high water temperature, approximately 240°F (116°C), or overspeed approximately +15%. The alarm lamps on the ECU illuminate to signify the reason for the shutdown.

### NOTICE

Before inspecting the generator, check that the Auto Start/Stop switch is in the **OFF/RESET** position, and place all circuit breakers in the **OFF** position. Allow sufficient time for adequate cooling. When ready to restart, complete all steps in the Generator Startup Procedure section of this manual.

# MAINTENANCE

Table 14. Inspection/Maintenance		10 Hours or Daily	250 Hours	500 Hours or Every 12 Months	2,500 Hours	Other
Engine	Check Engine Oil and Coolant Levels	X				
	Check Fuel Filter/Water Separator Bowl	X				
	Check Air Cleaner/Element	X				
	Clean or Replace Air Cleaner/Element		X			
	Check for Leaks/Hoses/Clamps	X				
	Check for Loosening of Parts	X				
	Change Engine Oil and Oil Filter* <sup>1</sup>		X			
	Clean Unit, Inside and Outside		X			
	Replace Fuel Filter Elements			X		
	Check Engine Mounts			X		
	Service Battery			X		
	Check Air Intake Hoses			X		
	Check Fan Belt Condition			X		
	Check Automatic Belt Tensioner			X		
	Check Electrical Ground Connection			X		
	Clean Radiator, Check Cooling System			X		
	Coolant Solution Analysis, Add SCAs as Required			X		
	Pressure Test Cooling System			X		
	Check Engine Speed			X		
	Test Thermostats				X	
	Check and Adjust Engine Valve Clearance					1,000 hours
	Test Glow Plugs				X	
	Replace DEF Filter (In Supply Module)					4,500 hours
	Replace DOC Catalyst* <sup>5</sup>					As required
	Check SCR System* <sup>2</sup>					4,500 hours
	Inspect Dosing Module (SCR System)					4,500 hours
	Flush and Refill Cooling System* <sup>3</sup>					1 year or 2,000 hours
Clean Inside of Fuel Tank					1,000 hours	
Clean DEF Tank					As required	
Replace Air Cleaner Elements* <sup>4</sup>					As required	
Generator	Measure Insulation Resistance Over 3M Ohms		X			
	Check Rotor Rear Support Bearing			X		

\*<sup>1</sup> During initial operation of a new engine, change oil and filter between a minimum of 100 hours and a maximum of 250 hours. Service interval depends on type of oil.

\*<sup>2</sup> Perform inspection and maintenance of urea SCR system every 4,500 hours. The system does not need to be replaced/exchanged if no problem is found. Do not make any modifications or changes, nor remove the emission control system and related parts. Please contact your nearest dealer or Multiquip Service Dept. for SCR maintenance.

\*<sup>3</sup> Use fully formulated antifreeze/coolant. If John Deere Cool-Gard™ II is used, flushing intervals may be extended.

\*<sup>4</sup> Replace primary air cleaner filter element when restriction indicator shows a vacuum of 625 mm (25 in. H<sub>2</sub>O).

\*<sup>5</sup> Service should be done as indicated by Diagnostic Gauge. Contact Multiquip Service Dept. for DOC replacement.

\* Accumulation of carbon (soot, unburned fuel) in the exhaust pipe line and muffler could cause not only system derates but also could lead to fire incident. To destroy the soot and unburned fuel, run the unit at rated power for some period of time until the exhaust gas become mostly colorless every 250 hours of operation time. The carbon will be easier to be generated when the unit operates at less than 30% of rated power. In this case, perform the above procedures at a shorter interval time.

\* Applying a large load at one time to the unit when carbon deposits have accumulated in the exhaust system could produce fire/sparks which could lead to abnormal combustion. Therefore it is recommended to **apply the load gradually** and observe the exhaust gas color (colorless) during the process.

\* Fire or sparks may emit from the exhaust gas outlet during the **carbon emission accumulation check** (load). Make sure the area surrounding the unit is free from any **flammable** material.

## GENERAL INSPECTION

Prior to each use, the generator should be cleaned and inspected for deficiencies. Check for loose, missing or damaged nuts, bolts or other fasteners. Also check for fuel, oil, and coolant leaks. Use Table 14 as a general maintenance guideline **Engine Side** (Reference Engine Instruction Manual).

## ENGINE AIR CLEANER

This John Deere diesel engine is equipped with a replaceable, high-density, paper air cleaner element. This air cleaner is also equipped with an inner element (secondary) that is used as a backup filter should the primary element become damaged. Check the air cleaner daily or before starting the engine. Replace the air cleaner as needed.

### NOTICE

If the engine is operating in very **dusty** or **dry** grass conditions, a clogged air cleaner will result. This can lead to a loss of power, excessive carbon buildup in the combustion chamber, and high fuel consumption. Change the air cleaner more **frequently** if these conditions exist.

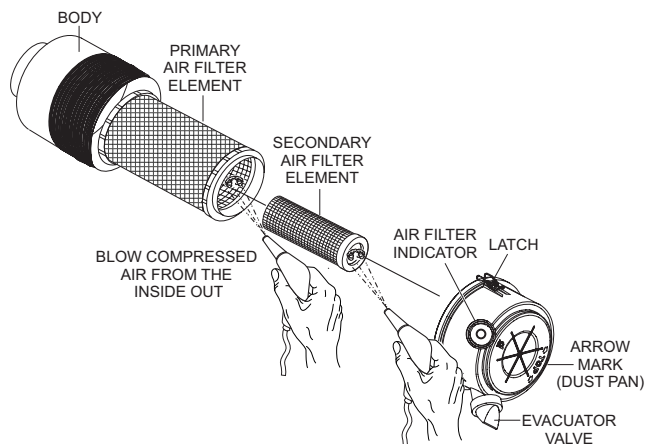

**Figure 59. Engine Air Cleaner**

## Primary And Secondary Air Cleaner Elements

**Every 250 hours:** Remove the air cleaner elements (Figure 59) and clean the heavy-duty paper element with a light spray of compressed air.

1. Release the latches (Figure 59) that secure the cover to the air cleaner body.
2. Remove the air cleaner cover and set it aside.
3. Remove both the primary and secondary air cleaner elements.
4. Check the air cleaner daily or before starting the engine.
5. Check for and correct heavy buildup of dirt and debris along with loose or damaged components.

### NOTICE

Operating the engine with loose or damaged air cleaner components could allow unfiltered air into the engine causing premature wear and failure.

6. To clean the primary element (paper air filter) as referenced in Figure 59, tap the filter element several times on a hard surface to remove dirt, or blow compressed air, not to exceed 30 psi (207 kPa, 2.1 kgf/cm<sup>2</sup>), through the filter element from the inside out.
7. Clean the secondary element (paper air filter) as referenced in step 6.
8. Replace both elements if they are damaged or excessively dirty.
9. Clean the inside of the air cleaner body.
10. Reinstall the primary and secondary air filter elements back into the air cleaner body.
11. Reinstall the air cleaner cover and secure with latches.

### NOTICE

**DO NOT** run the engine with the air cleaner removed or without an element.

## Air Cleaner Restriction Indicator

The air cleaner is equipped with a restriction indicator (Figure 60). As the air cleaner element becomes clogged, air intake restriction increases and the indicator signal shows **RED**, indicating that the element needs to be replaced. After replacing the air cleaner element, press the restriction indicator button to reset the indicator.

PUSH BUTTON TO RESET



**Figure 60. Air Cleaner Restriction Indicator**

### NOTICE

The air cleaner element should not be changed until the indicator displays **RED**. Dispose of the old element. It cannot be cleaned or reused.

## ENGINE FUEL FILTER

Inspect the engine fuel filter daily. If the fuel filter has collected a significant amount of water and sediment at the bottom of the cup, it should be drained off immediately.

## Draining The Fuel Filter

1. Loosen the air bleeder plug (Figure 61) on the fuel filter body.
2. To discharge the fuel inside the fuel filter cartridge, **OPEN** the drain valve on the fuel filter by turning the knob **counterclockwise** (Figure 61A) approximately 3-1/2 turns until the valve drops down 1 inch (25.4 mm) and draining occurs (Figure 61B).

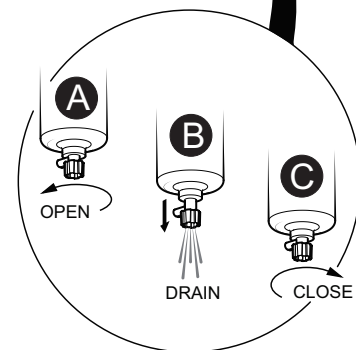
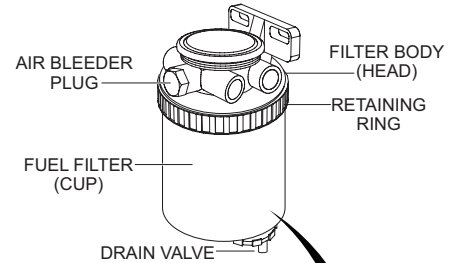
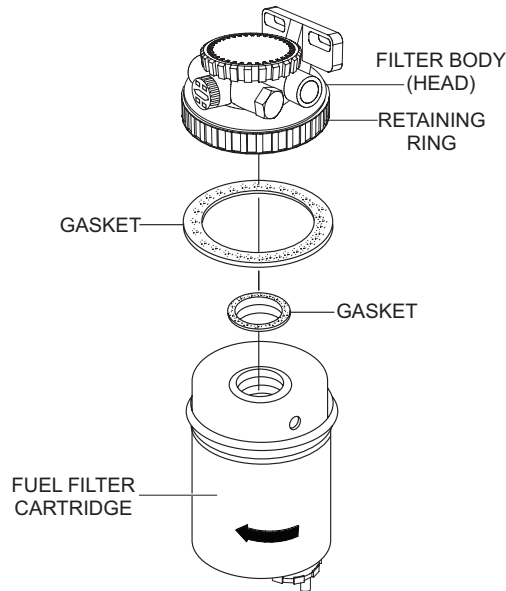

**Figure 61. Fuel Filter Draining**

3. Let the residue or foreign substances inside the cartridge flow into a suitable container.
4. At completion of draining, **CLOSE** the drain valve (Figure 61C).

## FUEL FILTER ELEMENT REPLACEMENT

1. Use a filter wrench to remove the fuel filter cup (Figure 62) from the fuel filter body.

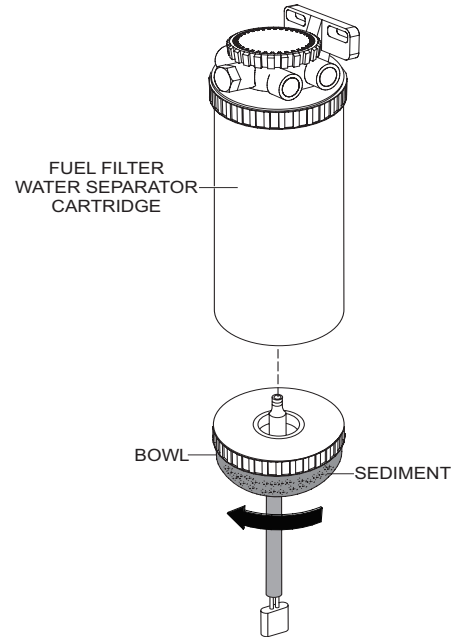

**Figure 62. Fuel Filter Cartridge Replacement**

2. Wipe the inside of the filter body (head) with a clean cloth to remove any foreign matter or debris that may have accumulated.
3. Replace both gaskets. Coat each gasket with a small amount of clean 15W-40 engine oil.
4. Install the new fuel filter cartridge first by hand until it makes contact with the fuel filter body surface.
5. Tighten the fuel filter cartridge securely. **DO NOT** over-tighten.
6. Remove the air from the fuel system. Reference John Deere Owner's Manual, "Bleeding the Fuel System."

## FUEL WATER SEPARATOR SEDIMENT BOWL

1. Remove the sediment bowl from the fuel water separator cartridge as shown in Figure 63.

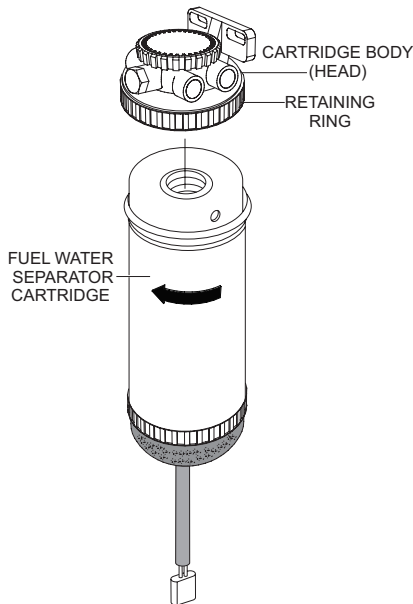

**Figure 63. Sediment Bowl**

2. Let the residue or foreign substances inside the sediment bowl flow into a suitable container.
3. Wipe the inside of the sediment bowl with a clean cloth to remove any foreign matter or debris that may have accumulated.
4. Reinstall the sediment bowl back onto the fuel water separator cartridge
5. Tighten securely. **DO NOT** over-tighten.

## FUEL WATER SEPARATOR REPLACEMENT

1. Use a filter wrench to remove the fuel water separator cartridge (Figure 64) from the cartridge body head.



**Figure 64. Fuel Water Separator**

2. Wipe the inside of the fuel water separator cartridge body (head) with a clean cloth to remove any foreign matter or debris that may have accumulated.
3. Install the new fuel water separator cartridge first by hand until it makes contact with the cartridge body (head) surface.
4. Tighten the fuel water cartridge securely. **DO NOT** over-tighten.

## CLEANING INSIDE THE FUEL TANK

If necessary, drain the fuel inside the fuel tank completely. Using a spray washer (Figure 65) wash out any deposits or debris that have accumulated inside the fuel tank.



**Figure 65. Fuel Tank Cleaning**

## FUEL TANK INSPECTION

In addition to cleaning the fuel tank, the following components should be inspected for wear:

- **Rubber Suspension** — Look for signs of wear or deformity due to contact with oil. Replace the rubber suspension if necessary.
- **Fuel Hoses** — Inspect nylon and rubber hoses for signs of wear, deterioration or hardening.
- **Fuel Tank Lining** — Inspect the fuel tank lining for signs of excessive amounts of oil or other foreign matter.

## DRAINING ENGINE OIL

1. Run the engine until the engine coolant reaches a temperature of 140°F (60°C). Turn the engine off.
2. Remove the oil dipstick from its holder.
3. Remove the **oil drain cap** (Figure 66).
4. Place the **oil drain valve** in the **OPEN** position and allow the oil to drain into a suitable container.

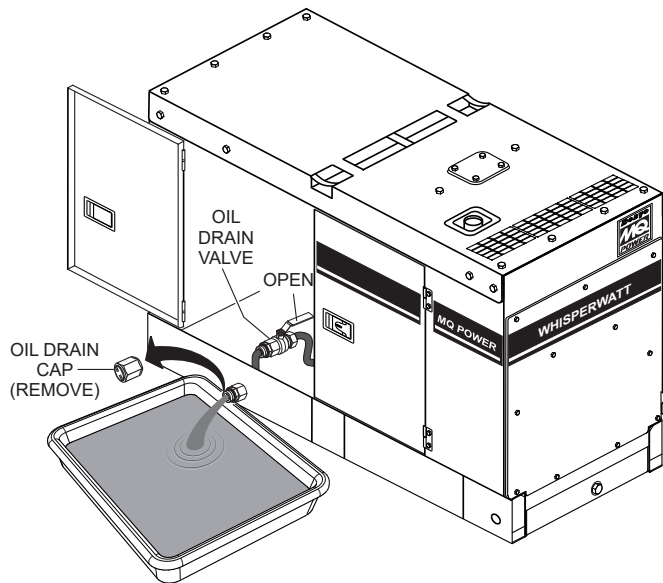

Figure 66. Draining Engine Oil

5. After the engine oil has been completely drained, reinstall the oil drain cap and tighten securely.
6. Place the **oil drain valve** in the **CLOSED** position.

## ENGINE OIL FILTER REPLACEMENT

1. Clean the area around the lubricating oil filter head.
2. Using an oil filter wrench (Figure 67), remove the engine oil filter.

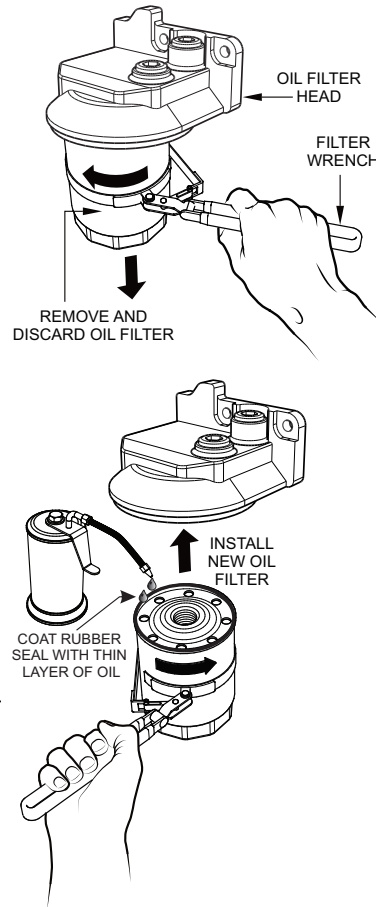

Figure 67. Oil Filter Removal

3. Coat the rubber seal (gasket) surface of the oil filter (Figure 67) with clean 15W-40 engine oil.
4. Install the new oil filter (main) first by hand until it makes contact with the filter head surface. Tighten it another 3/4 turn using the filter wrench.
5. Fill the engine crankcase with high-quality detergent oil classified "For Service CI-4." Fill to the upper limit of the dipstick. **DO NOT** overfill. Reference Table 2 for engine crankcase oil capacity.
6. Run the engine for several minutes. Watch for oil leakage. Shut the engine down and allow it to sit for several minutes. Top off the oil to the upper limit on the dipstick.

## DRAINING ENGINE COOLANT

### WARNING

**DO NOT** remove the pressure cap from the radiator when the engine is hot! Wait until the coolant temperature is below 120°F (50°C) before removing the pressure cap.

Heated coolant spray or steam can cause severe scalding and personal injury.

1. Remove the radiator pressure cap (Figure 68) only if the coolant temperature is below 120°F (50°C).

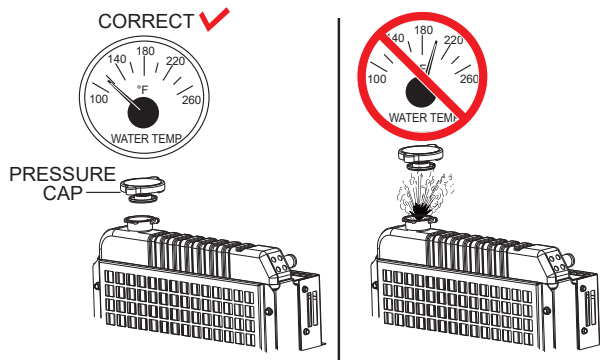

**Figure 68. Radiator Pressure Cap Removal**

2. Open the cabinet door and remove the coolant drain bolt and O-ring (Figure 69), then allow the coolant to drain into a suitable container.

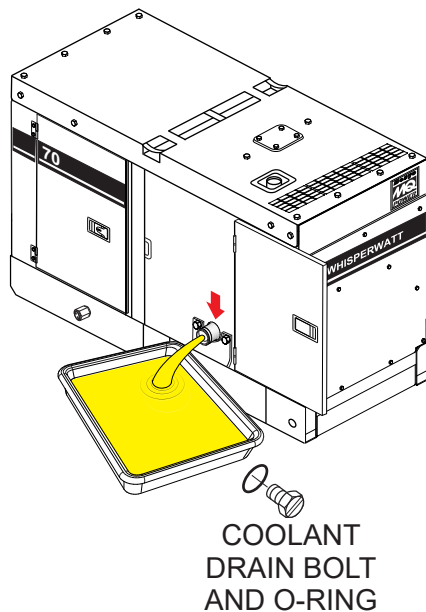

**Figure 69. Draining Radiator Coolant**

## FLUSHING OUT THE RADIATOR AND REPLACING COOLANT

- Open both cocks located at the crankcase side and at the lower part of the radiator and drain the coolant. Open the radiator cap while draining. Remove the overflow tank and drain.
- Check hoses for softening and kinks. Check clamps for signs of leakage.
- Tighten both cocks and replace the overflow tank.
- Replace with coolant as recommended by the engine manufacturer.
- Close the radiator cap tightly.
- Flush the radiator by running clean tap water through the radiator until signs of rust and dirt are removed. **DO NOT** clean the radiator core with any objects, such as a screwdriver.

### WARNING



Allow the engine to **cool** when flushing out the radiator. Flushing the radiator while hot could cause serious burns from water or steam.

## RADIATOR CLEANING

The radiator (Figure 70) should be sprayed (cleaned) with a high-pressure washer when excessive amounts of dirt and debris have accumulated on the cooling fins or tube. When using a high-pressure washer, stand at least 5 feet (1.5 meters) away from the radiator to prevent damage to the fins and tube.

### NOTICE

It may be necessary to remove additional generator components in order to access the radiator for cleaning.



Figure 70. Radiator Cleaning

## DRIVE BELT (DAILY)

### Drive Belt Tension

A slack drive belt (Figure 71) may contribute to overheating or insufficient charging of the battery. Adjust the drive belt in accordance with the John Deere Engine Owner's manual.

### Drive Belt Inspection

Inspect the drive belt for damage and wear. Horizontal cracks (across the belt) are acceptable. Vertical (direction of belt ribs) cracks that intersect with horizontal cracks are not acceptable.

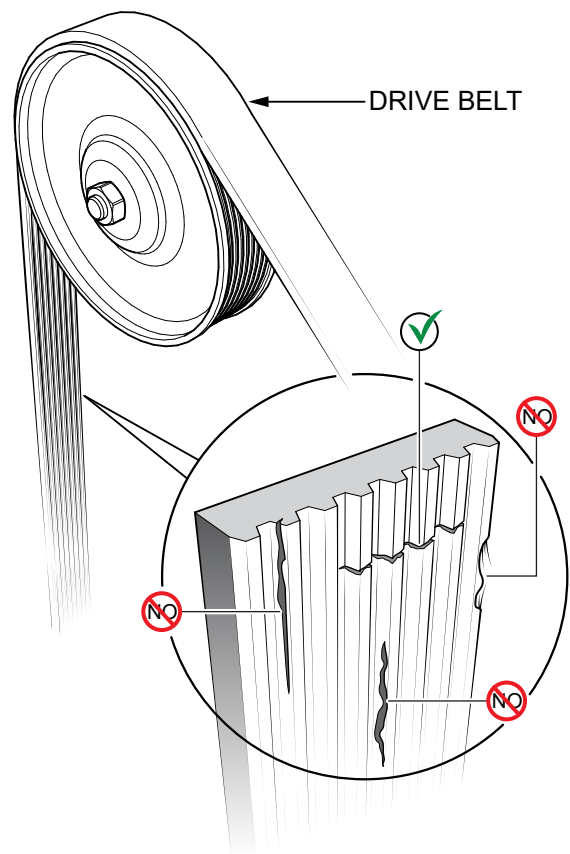

Figure 71. Drive Belt Inspection

Also, examine the belt and determine if it is **oil soaked** or **glazed** (a hard shiny appearance on the sides of the belt). Either of these two conditions can cause the belt to run hot, which can weaken it and increase the danger of it breaking.

If the drive belt exhibits any of the above wear conditions, replace the drive belt immediately.

## TESTING THE GFCI RECEPTACLE

### NOTICE

The GFCI receptacle is designed to interrupt power when a ground fault exists to prevent injuries and shock hazards. **DO NOT** use the GFCI receptacle if the test below fails. Consult a qualified electrician for repair or replacement of the GFCI receptacle. Test the GFCI receptacle **at least once a month**.

1. Start the generator as outlined in the start-up procedure in this manual.
2. Place a GFCI circuit breaker (Figure 72) in the **ON** position.

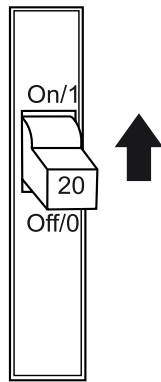

**Figure 72. GFCI Circuit Breaker**

3. Verify that the status LED on the corresponding GFCI receptacle (Figure 73) is **ON (GREEN)**.

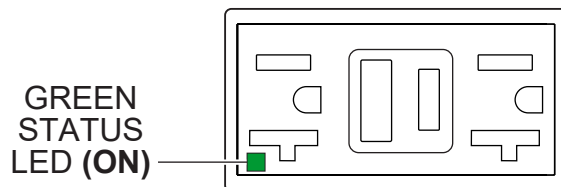

**Figure 73. GFCI Receptacle (ON)**

4. Press the **TEST** button (Figure 74) on the GFCI receptacle and verify that the status LED turns **OFF**.

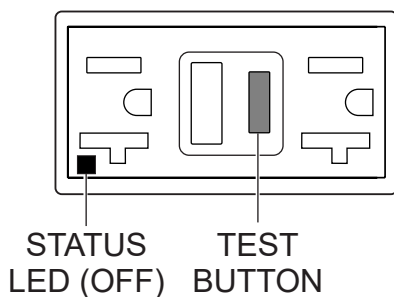

**Figure 74. GFCI Receptacle (OFF)**

5. Press the **RESET** button (Figure 75) to restore power to the GFCI receptacle and verify that the status LED is **ON (GREEN)**.

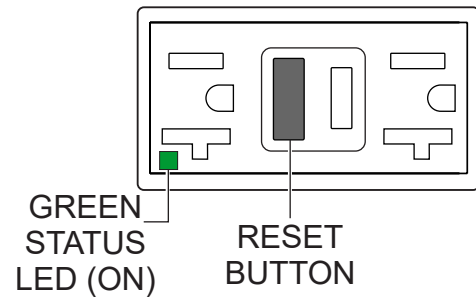

**Figure 75. GFCI Receptacle (ON/Restore)**

6. If the status LED (Figure 76) is **flashing (RED)**, **DO NOT** use the GFCI receptacle and replace it immediately.

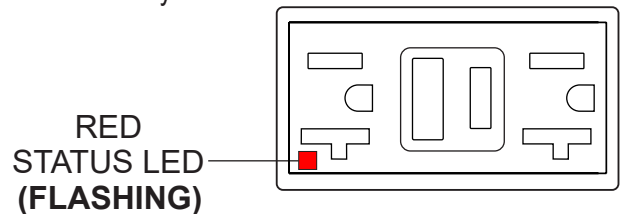

**Figure 76. GFCI Receptacle (RED Flashing LED)**

7. Repeat the above procedure for any other GFCI receptacles.

## GENERATOR STORAGE

For long-term storage of the generator the following is recommended:

- Drain the fuel tank completely. Treat with a fuel stabilizer if necessary.
- Completely drain the oil from the crankcase and refill if necessary with fresh oil.
- Clean the entire generator, internal and external.
- Cover the generator and store in a clean, dry place.
- Disconnect the battery.
- Make sure engine coolant is at the proper level.
- If the generator is mounted on a trailer, jack the trailer up and place it on blocks so the tires do not touch the ground, or block and completely remove the tires.

## ENGINE BLOCK HEATER AND OPTIONAL INTERNAL BATTERY CHARGER 120 VAC INPUT RECEPTACLES

This generator comes equipped with an **engine block heater**. An **internal battery charger** is available as an **option**. These components are provided with electrical power cords to connect to a commercial power source.

The engine block heater and internal battery charger both require 120 VAC in order to operate. A receptacle (Figure 77) has been provided on the output terminal panel to allow commercial power to be applied.

These receptacles will **ONLY** function when commercial power has been supplied to them (Figure 77). To apply commercial power to these receptacles, a power cord of adequate size will be required (See Table 6).

When using the generator in **hot** climates there is no reason to apply power to the engine block heater. However, if the generator will be used in **cold** climates it is always a good idea to apply power to the engine block heater at all times.

If the generator will be used daily, the battery should normally not require charging. If the generator will be idle (not used) for long periods of time, apply power to the battery charger receptacle via commercial power using a power cord of adequate size.

### NOTICE

If the generator will be idle (not used) for long periods of time and to ensure adequate starting capability, always have power applied to the generator's internal battery charger.

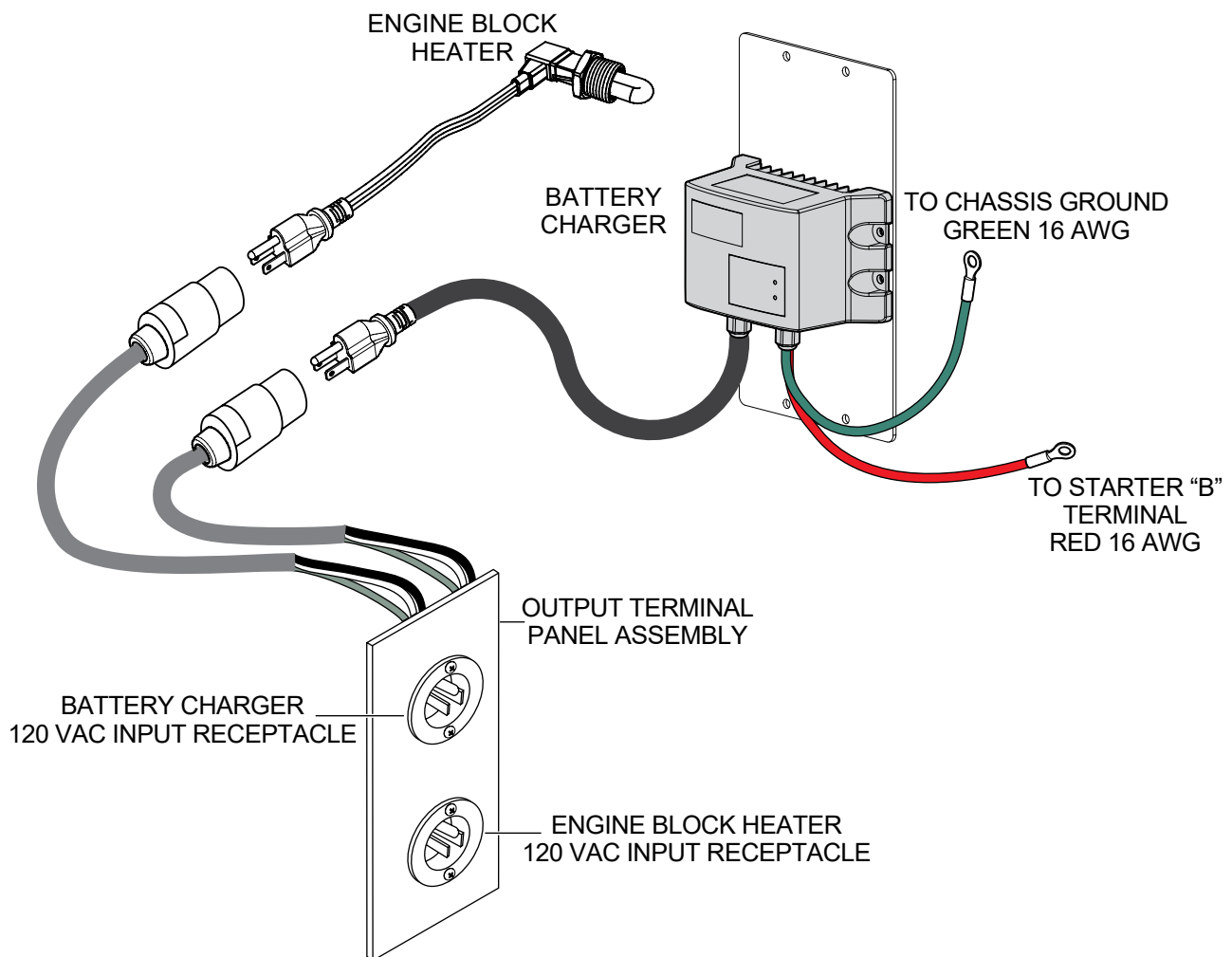

Figure 77. Engine Block Heater And Optional Battery Charger

## EMISSION CONTROL

The emission control system employed with the John Deere 4045HFG diesel engine consists of a Diesel Oxidation Catalyst (DOC).

This device oxidizes large amounts of harmful nitrogen oxides (NO<sub>x</sub>) and particulate matter (PM) which are emitted by diesel engines. These exhaust emissions pose serious environmental and health risks. No maintenance or service is required for the DOC device used on this generator.

### Diesel Oxidation Catalyst (DOC)

The DOC (Figure 78) does not filter particles, it oxidizes them. This catalyst (honeycomb-like structure) uses a chemical process to break down pollutants in the exhaust stream into less harmful components. In general this catalyst collects/burns accumulated particulates. The DOC contains palladium and platinum which serve as catalysts to oxidize hydrocarbons and carbon monoxide.

## PREVENTIVE MAINTENANCE PROGRAMS

Most challenging to a rental organization is the fact that a customer's power assumptions may not meet the minimum load requirements of the power equipment selected. When in doubt, it is always recommended to apply a **load bank application** to the equipment following a longer rental period.

Equipment on extended, long-term contracts needs periodic on-site inspection. If possible, interview the operator and survey the equipment hooked up to the generator to estimate load conditions.

Preventive maintenance and a few extra steps prevent downtime and protect your investment and business. A well-planned preventive maintenance program will reward you with years of service.

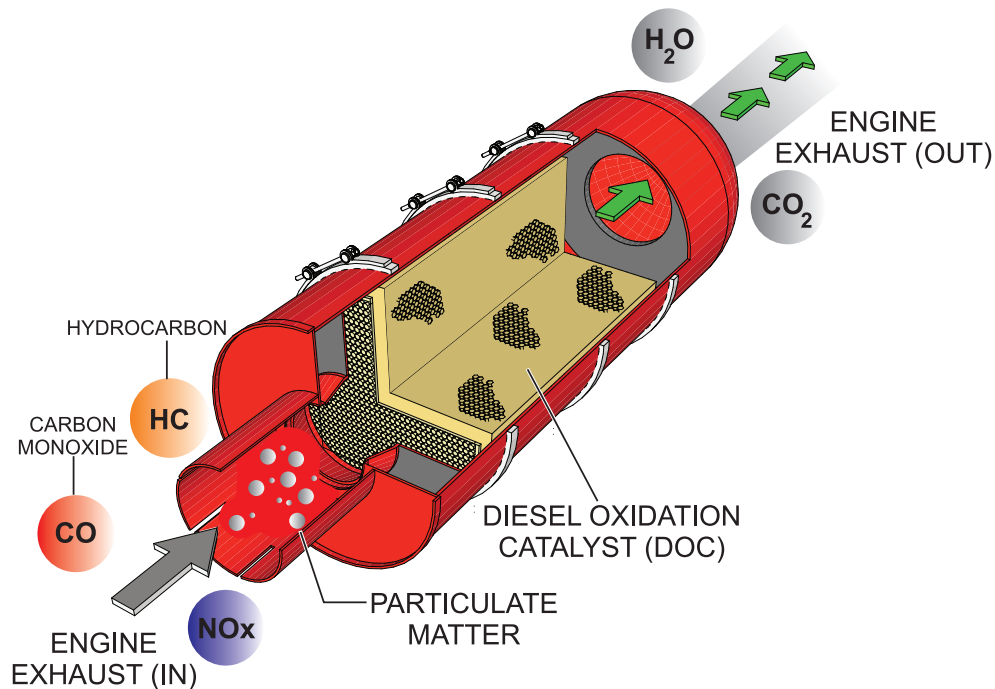

Figure 78. Diesel Oxidation Catalyst (DOC)

## SELECTIVE CATALYTIC REDUCTION (SCR)

Diesel engines can be run with a lean burn air-to-fuel ratio, to ensure the full combustion of soot and to prevent the exhaust of unburnt fuel. The excess of air necessarily leads to generation of nitrogen oxides ( $\text{NO}_x$ ), which are harmful pollutants, from the nitrogen in the air. **Selective Catalytic Reduction** is used to reduce the amount of  $\text{NO}_x$  released into the atmosphere.

**Diesel Exhaust Fluid** (DEF) from a separate tank is injected into the exhaust pipeline, where the aqueous urea vaporizes and decomposes to form ammonia and carbon dioxide. Within the SCR catalyst, the  $\text{NO}_x$  are catalytically reduced by the ammonia ( $\text{NH}_3$ ) into water ( $\text{H}_2\text{O}$ ) and nitrogen ( $\text{N}_2$ ), which are both harmless; these are then released through the exhaust.

The SCR system creates a certain amount of ammonia ( $\text{NH}_3$ ) that is stored in SCR catalyst. During purging operations the increase in temperature at regular intervals eliminates the stored ammonia.

The process of keeping accurate ammonia storage amounts is by counting urea injection quantities from the Dosing Control Unit (DCU).

The SCR Purge symbol (Figure 79) will be displayed on the ECU controller during operation when either an **automatic** or **forced** regeneration is in process.

The pre-alarm lamp is only **ON** during SCR forced regeneration and **OFF** during automatic regeneration.

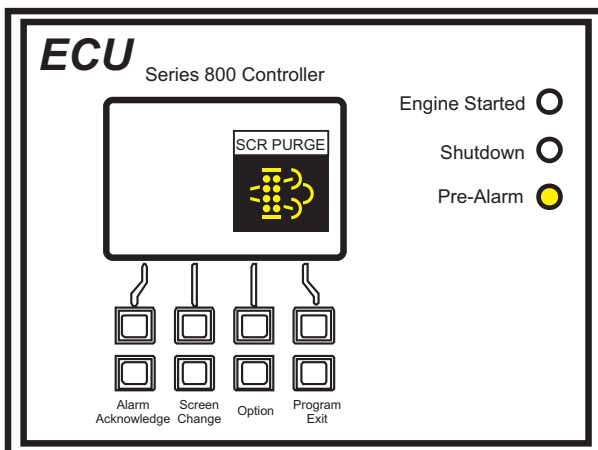

Figure 79. SCR Purge Symbol

### NOTICE

During urea SCR regeneration, **white smoke** may be temporarily emitted from the exhaust tailpipe. This should not be considered a failure. In addition, the smell of **ammonia** during the regeneration process should not be considered a failure.

If the regeneration process is underway while running a light load (0–30%) the unit may produce unusual sounds. This should not be considered a failure or malfunction.

## REGENERATION GUIDELINES

### NOTICE

**DO NOT** perform regeneration in conditions where it may be unsafe due to high exhaust temperatures.

For safe operation of equipment, safety of the surrounding area, and the prevention of bodily harm, use the guidelines below when regeneration is required:

### NOTICE

The area above and around the generator during the regeneration process should be free of any type of debris or flammable or combustible materials, as temperatures during the regeneration process can reach as high 1,022°F (550°C).

- **DO NOT** operate the unit in an area with poor ventilation.
- If operating the engine indoors, install exhaust/ventilation equipment and ensure that there is sufficient ventilation.
- If you begin to feel sick, stop the unit immediately and ventilate the area.
- Due to the exhaust emission reduction functions of the exhaust system, exhaust emissions from the tailpipe have a different smell from those emitted from engines without urea SCR systems.

If the **diesel exhaust fluid (DEF)** symbol (Figure 80) is displayed during ECU controller operation, it indicates the following:

- DEF tank level is below 10%. Reference Table 15, DEF Level System Action System.
- DEF quality is poor. Check DEF tank level and check active **diagnostic trouble codes (DTC)**.

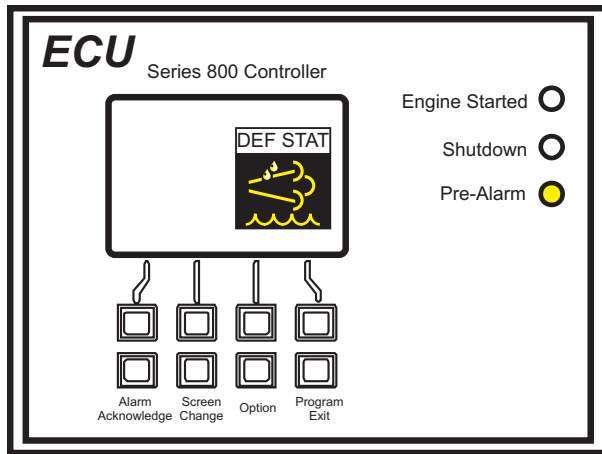

Figure 80. ECU DEF State Pre-Alarm

## DIESEL EXHAUST FLUID (DEF)

The amount of fluid in the DEF tank will be shown on the ECU Controller main screen during operation. The symbol shown in Figure 81 will be shown on the ECU monitor indicating the level of fluid in the DEF tank.

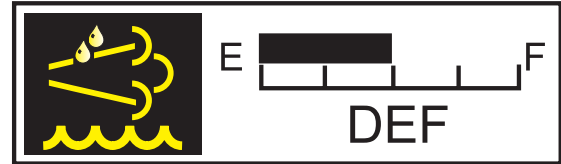

Figure 81. DEF Tank Level Gauge

### NOTICE



The unit will enter emergency shutdown when the DEF level has reached 0% and emergency protective measures are necessary. When this condition exists, the unit can only be restarted after ESCAPE MODE is activated and the unit will run for 30 minutes. Reference the “Escape Mode” section in this manual.

Table 15. DEF Level System Action

DEF Level	Over 10%	Below 10%	0%	0%
Controller Message	—	DEF <10% Tank Level	DEF 0% Tank Level	DEF at 0% Level Shutdown
DEF Symbol	—	● ON	● Blinking	● Blinking
Pre-Alarm Lamp	—	—	● ON	● ON
Shutdown Lamp	—	—	—	● ON Engine Shutdown

## INDUCEMENT

When the system senses improper usage such as no supply of DEF, use of poor quality DEF, problems with DEF jets, or disconnection of sensors, a warning will be issued before the situation becomes critical. If the warnings are ignored and the unit enters intermittent operation, the emergency shutdown will activate. The three warning levels are referenced in Table 16:

Table 16. DEF Inducement					
Stage	Controller Message	SCR System Pop-Up	DEF Symbol	Pre-Alarm Lamp	Shutdown Lamp
Stage 1 Warning Level 1	SCR System Malfunction	SCR SYS ERR		● ON	—
Stage 2 Warning Level 2	SCR System Malfunction	SCR SYS ERR	 Slow Blinking	● ON	—
Stage 3 Shutdown <sup>1</sup>	SCR System Malfunction	SCR SYS ERR	 Fast Blinking	● ON	● ON

<sup>1</sup>When emergency shutdown occurs, inspection and repair should generally be performed promptly. **Escape mode** operation will be available until around 30 minutes after operation has ended. If Escape mode is temporarily suspended before the end of the 30-minute period, it is not necessary to request Escape mode again when the unit is restarted. The 30-minute countdown from before the last shutdown will resume automatically once the unit is restarted.

## HOW TO ACTIVATE ESCAPE MODE

If the ECU displays any messages referenced in Table 16, it may be necessary to restart via **ESCAPE MODE**.

### Starting

1. Start the Diagnostic Mode as referenced in the “Troubleshooting Diagnostics” section in this manual.
2. Exit the Status Check Screen by pressing the [EXIT] button (Figure 82).

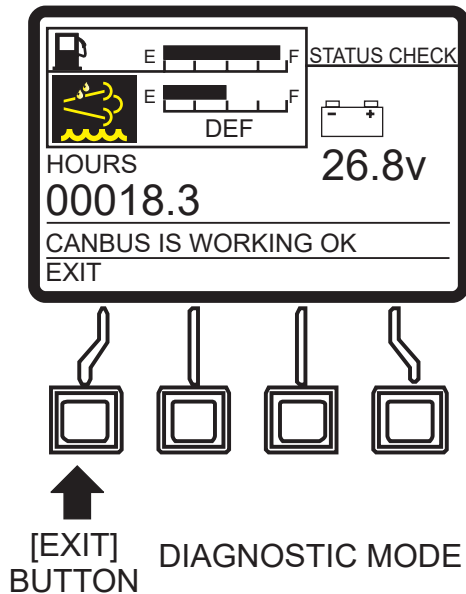

**Figure 82. Status Check Screen (Diagnostic Mode)**

3. Press the [Program/Exit] button (Figure 83) to enter the Main Menu.

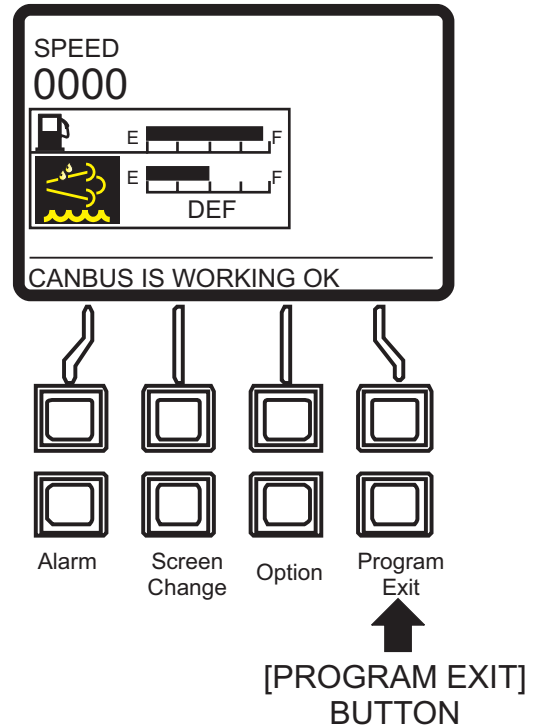

**Figure 83. Main Screen**

4. Press the [DOWN] button (Figure 84) to scroll to the Escape Mode item.

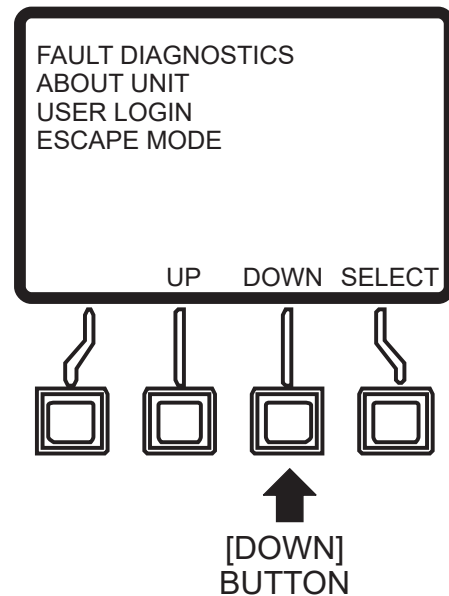

**Figure 84. Main Menu (Down Button)**

5. Press the **[SELECT]** button (Figure 85) to enter the “Escape Mode” menu.

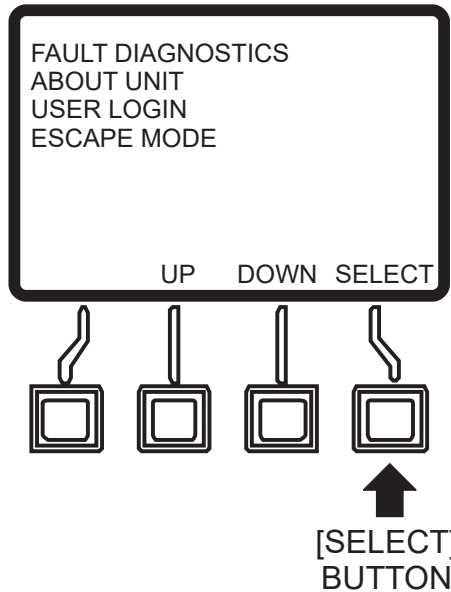

**Figure 85. Main Menu (Select Button)**

6. Press the **[REQUEST]** button (Figure 86) to send “Escape Mode Request” signal to ECM.

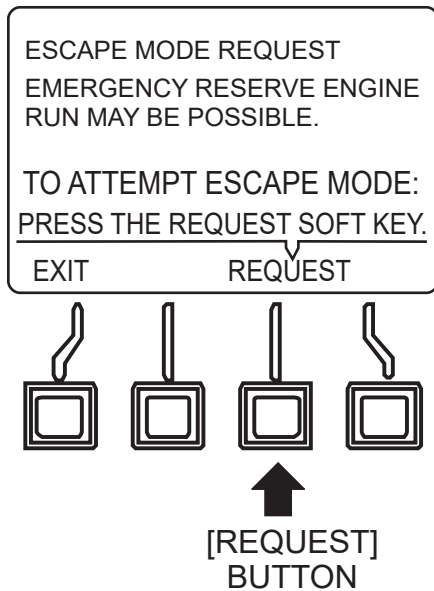

**Figure 86. Escape Mode (Request Button)**

7. Place the Auto Start/Stop Switch (Figure 87) in the “Off/Reset” position.

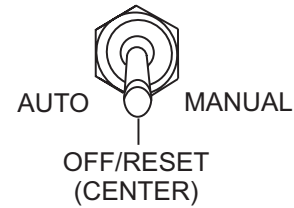

**Figure 87. Auto Start/Stop Switch (Off/Reset Position)**

8. Place the Auto Start/Stop Switch (Figure 88) in the “Manual” position to start the engine.



**Figure 88. Auto Start/Stop Switch (Manual Position)**

9. The **Escape Mode Timer** (Figure 89) will appear on the *main* screen. This timer displays the remaining Escape Mode operation time.

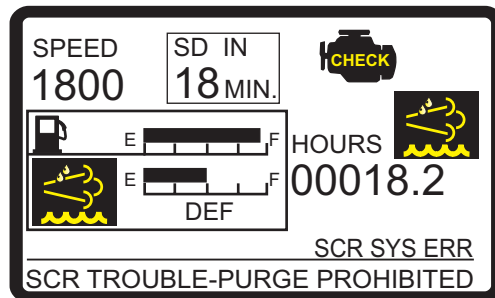

**Figure 89. Escape Mode Timer**

- If ESCAPE MODE is temporarily suspended, it is not necessary to return to the ESCAPE MODE screen and press the **[REQUEST]** button. ESCAPE MODE operation will be available until around 30 minutes after operation has been ended.
- Once the ESCAPE MODE timer reaches zero minutes, the engine will stop since the ESCAPE MODE time has expired. Please perform maintenance to return the unit to proper operating condition.
- If the unit returns to Warning Level 1 while ESCAPE MODE is running, ESCAPE MODE will be cancelled, the ESCAPE MODE timer display will close, and normal operation will resume.

## PROTECTION DEVICES

### Automatic Shutdown System

This unit is equipped with engine protection devices that automatically shut down the engine if any of the faults shown in Table 17 occur. The “Shutdown” LED on the ECU Controller will turn on just before the shutdown and will stay on after the shutdown. Messages will appear on the ECU display.

After the automatic shutdown, check all Diagnostic Trouble Codes (DTC) displayed on the ECU Controller. Reference the Troubleshooting (Diagnostics) section in this manual.

Place the Auto Start/Stop Switch in the “Off/Reset” position. In addition, place all circuit breakers in the **OFF** position. Before troubleshooting, allow sufficient time for adequate cooling. Before attempting to restart the generator, perform an overall inspection of the generator and correct the problem that caused the shutdown. If necessary, contact your nearest Multiquip dealer for additional technical support.

Restart the generator as referenced in the Generator Startup Procedure (Manual Start).

#### NOTICE

Although the unit is equipped with engine protection devices, regularly scheduled **preventative maintenance** is strongly advised.

**Table 17. Automatic Engine Shutdown System**

Operating Parameter	ECU Shutdown LED	Operating Condition/Set Point
Low Oil Pressure	● ON	Set Point: 17 psi (117 kPa)
High Water Temperature	● ON	Set Point: 240°F (116°C)
Low Coolant Level	● ON	Falls Below Specified Level
High Water Level in Fuel Water Separator	● ON	Water Level Has Exceeded Filter Capacity
High Engine Fuel Temperature	● ON	Fuel Temperature Too High
High Charged Air Cooler Outlet Temperature	● ON	CAC Temperature Too High
Exhaust System Severe Malfunction	● ON	Reference Exhaust System, DEF, Regeneration Sections
Over Voltage	● ON	Set Point: 110% of Rated Voltage
Under Voltage	● ON	Set Point: 75% of Rated Voltage
High Power (kW)	● ON	Set Point: 115% of Rated Power
Over Frequency (Hz)	● ON	Set Point: 110% of Rated Frequency
Under Frequency (Hz)	● ON	Set Point: 90% of Rated Frequency
Over Current	Main CB Trip	Load Capacity Exceeded

## TROUBLESHOOTING (DIAGNOSTICS)

The engine controller of this generator diagnoses problems (faults/errors) that arise from the engine control system and the engine itself.

1. With the engine stopped (**OFF**), push and hold the **Hour Check Button** (Figure 90) located on the control panel.

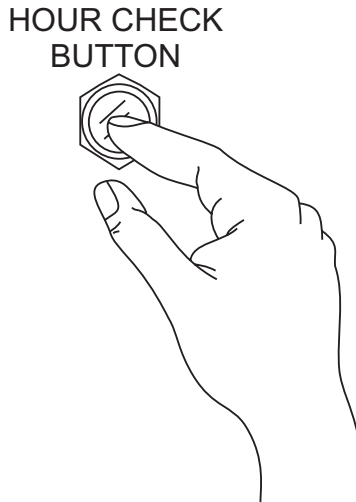

**Figure 90. Hour Check Button**

2. While keeping the **Hour Check Button** pressed, place the **Auto Start/Stop Switch** (Figure 91) in the **MANUAL** position.

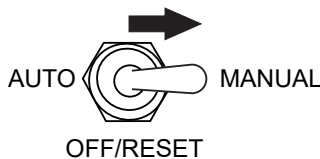

**Figure 91. Auto Start/Stop Switch  
(Manual Position)**

3. The **Hour Check Menu Screen** will be displayed on the ECU controller.
4. Releasing the **Hour Check Button** and pushing the **Program/Exit Button** on the ECU controller will return the controller to the main screen.

5. Push the **Program/Exit Button** on the ECU controller and select **Fault Diagnostics** mode. This mode enables the ability to carry out the fault diagnostics as listed below:

- **DM1 Active Faults** — Displays active fault messages and codes.
  - **DM2 Messages and Codes** — Displays messages and codes which previously occurred that are recorded in the Engine Control Module (ECM).
  - **Last Shutdown** — Displays the messages and codes that caused the most recent shutdown.
6. After performing diagnostic tests, place the **Auto Start/Stop Switch** in the **OFF** position.

## TROUBLESHOOTING (GENERATOR)

Practically all breakdowns can be prevented by proper handling and maintenance inspections, but in the event of a breakdown, use Table 18 shown below for diagnosis of the generator. If the problem cannot be remedied, consult our company's business office or service plant.

<b>Table 18. Generator Troubleshooting</b>		
<b>Symptom</b>	<b>Possible Problem</b>	<b>Solution</b>
No Voltage Output	Defective AC voltmeter?	Check output voltage and replace as necessary.
	Loose wiring connection?	Check wiring and repair.
	Defective AVR?	Replace if necessary.
	Defective rotating rectifier?	Check and replace.
Low Voltage Output	Low engine speed?	Check and adjust.
	Loose wiring connection?	Check wiring and repair.
	Defective AVR?	Replace if necessary.
High Voltage Output	Loose wiring connection?	Check wiring and repair.
	Defective AVR?	Replace if necessary.
Circuit Breaker Tripped	Short circuit in load?	Check load and repair.
	Over current?	Confirm load requirement and reduce.
	Defective circuit breaker?	Check and replace.
	Overcurrent relay actuated?	Confirm load requirement and reset.

## TROUBLESHOOTING (ENGINE)

Troubleshooting (Engine)		
Symptom	Possible Problem	Solution
Engine will not start or start is delayed, although engine can be turned over.	No fuel reaching injection pump?	Add fuel. Check entire fuel system.
	Defective fuel pump?	Replace fuel pump.
	Fuel filter clogged?	Replace fuel filter and clean tank.
	Faulty fuel supply line?	Replace or repair fuel line.
	Compression too low?	Check piston, cylinder and valves. Adjust or repair per engine repair manual.
	Fuel pump not working correctly?	Repair or replace fuel pump.
	Oil pressure too low?	Check engine oil pressure.
	Low starting temperature limit exceeded?	Comply with cold starting instructions and proper oil viscosity.
	Defective battery?	Charge or replace battery.
	Air or water mixed in fuel system?	Check carefully for loosened fuel line coupling, loose cap nut, etc.
At low temperatures engine will not start.	Engine oil too thick?	Refill engine crankcase with correct type of oil for winter environment.
	Defective battery?	Replace battery.
Engine fires but stops as soon as starter is switched off.	Fuel filter blocked?	Replace fuel filter.
	Fuel supply blocked?	Check the entire fuel system.
	Defective fuel pump?	Replace fuel pump.
Engine stops by itself during normal operation.	Fuel tank empty?	Add fuel.
	Fuel filter blocked?	Replace fuel filter.
	Defective fuel pump?	Replace fuel pump.
	Mechanical oil pressure shutdown sensor stops the engine due to low oil?	Add oil. Replace low oil shutdown sensor if necessary.
Low engine power, output and speed.	Fuel tank empty?	Add fuel.
	Fuel filter clogged?	Replace fuel filter.
	Fuel tank venting is inadequate?	Ensure tank is adequately vented.
	Leaks at pipe unions?	Check threaded pipe unions. Tape and tighten unions as required.
	Speed control lever does not remain in selected position?	See engine manual for corrective action.
	Engine oil level too full?	Correct engine oil level.
	Injection pump wear?	Use No. 2-D diesel fuel only. Check the fuel injection pump element and delivery valve assembly and replace as necessary.

## TROUBLESHOOTING (ENGINE)

<b>Troubleshooting (Engine) - continued</b>		
<b>Symptom</b>	<b>Possible Problem</b>	<b>Solution</b>
Low engine power output and low speed, black exhaust smoke.	Air filter blocked?	Clean or replace air filter.
	Incorrect valve clearances?	Adjust valves per engine specification.
	Malfunction at injector?	See engine manual.
Engine overheats.	Too much oil in engine crankcase?	Drain off engine oil down to upper mark on dipstick.
	Entire cooling air system contaminated or blocked?	Clean cooling air system and cooling fin areas.
	Fan belt broken or elongated?	Change belt or adjust belt tension.
	Coolant insufficient?	Replenish coolant.
	Radiator net or radiator fin clogged with dust?	Clean net or fin carefully.
	Fan, radiator, or radiator cap defective?	Replace defective part.
	Thermostat defective?	Check thermostat and replace if necessary.
	Head gasket defective or water leakage?	Replace parts.

# GENERATOR WIRING DIAGRAM (M2814000323)

SYMBOL	DESIGNATION
At	MAIN GENERATOR ARMATURE WINDING
Fb	MAIN GENERATOR FIELD WINDING
ExAt	EXCITER ARMATURE WINDING
ExFg	EXCITER FIELD WINDING
Re	RECTIFIER
AVR	AUTOMATIC VOLTAGE REGULATOR
VR	VOLTAGE REGULATOR RHIOSTAD 7W 144
CT 1, 2, 3	CURRENT TRANSFORMER 150:5A
CT 4, 5	CURRENT TRANSFORMER 150:5A
AS	CHANGE-OVER SWITCH, AMMETER
A	AC. AMMETER 0-150A 0-300A/5A
VS	CHANGE-OVER SWITCH, VOLTMETER
V	AC. VOLTMETER 0-600V
F	FREQUENCY METER 45-65Hz, 240V
CB1	CIRCUIT BREAKER 3P 200A
CB2, 3, 4	CIRCUIT BREAKER 2P 50A
CB5, 6	CIRCUIT BREAKER 1P 20A
CON1, 2, 3	RECEPTACLE 250V 50A
CON4, 5	RECEPTACLE 125V 20A x 2 (G. F. C. I.)
OC	OVER CURRENT RELAY
SW	SELECTOR SWITCH (11stages)
RY1, 2	RELAY UNIT

CT 1 ~ 5	
W	Written mark at CT
k	X1
l	No mark
K	H1
L	No mark

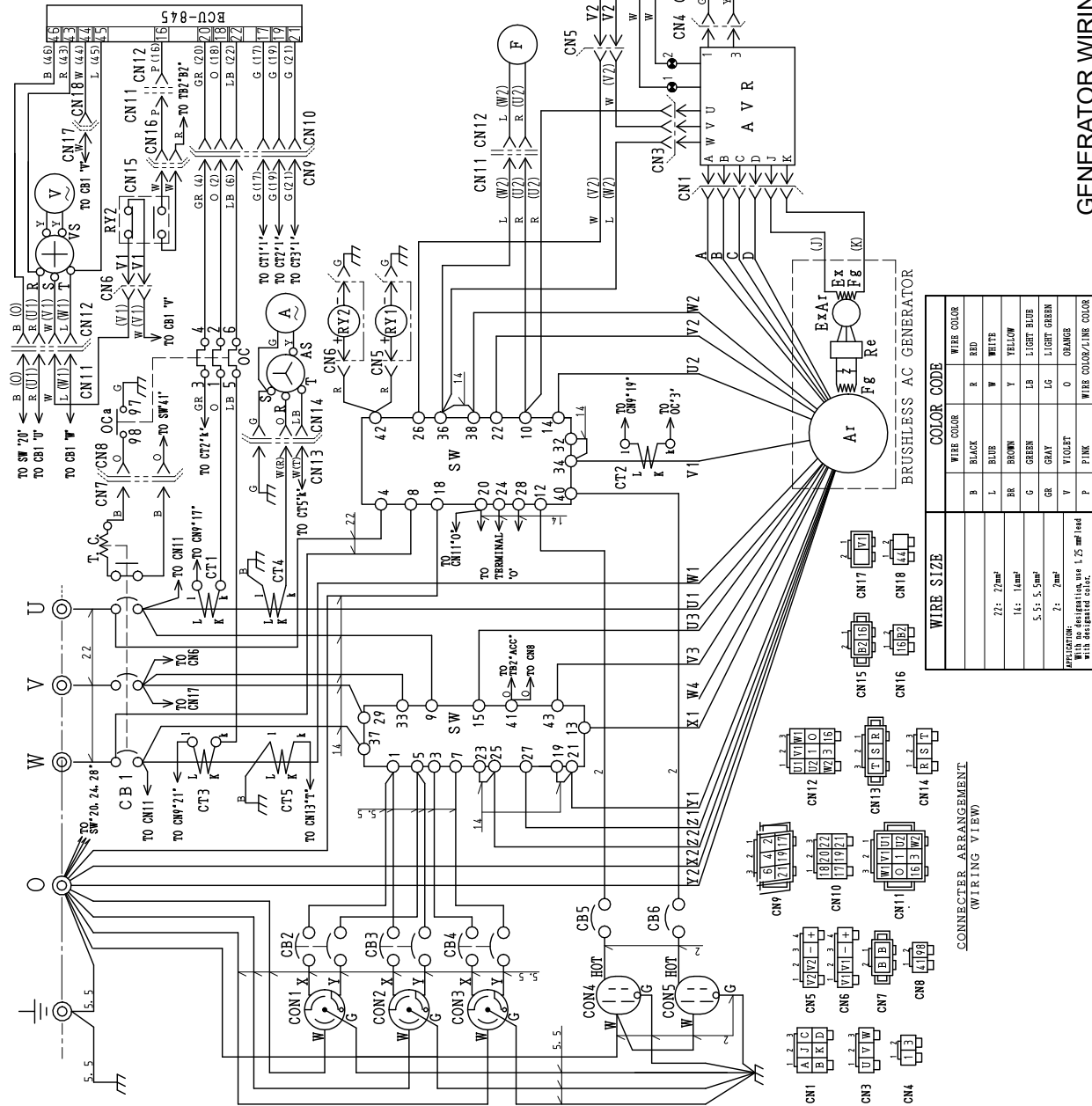

WIRE SIZE		COLOR CODE	
		WIRE COLOR	WIRE COLOR/LINE COLOR
		BLACK	R
		RED	RED
		BLUE	W
		WHITE	Y
		BROWN	BR
		YELLOW	Y
		GREEN	G
		LIGHT BLUE	LB
		GRAY	LG
		LIGHT GREEN	LG
		PINK	P
		ORANGE	O
		PIVOT	0
		ORANGE	O

CONNECTOR ARRANGEMENT (WIRING VIEW)	
CN1	A J C B K D
CN2	U V W
CN3	U V W
CN4	1 2 3
CN5	2 2 2 2 1 1 0
CN6	1 2 3 4
CN7	1 2 3 4
CN8	1 2 3 4
CN9	1 2 3 4
CN10	1 2 3 4
CN11	1 2 3 4
CN12	1 2 3 4
CN13	1 2 3 4
CN14	1 2 3 4
CN15	1 2 3 4
CN16	1 2 3 4
CN17	1 2 3 4
CN18	1 2 3 4
CN19	1 2 3 4

GENERATOR WIRING DIAGRAM NO. M2814000323

# ENGINE WIRING DIAGRAM (M2814100513)

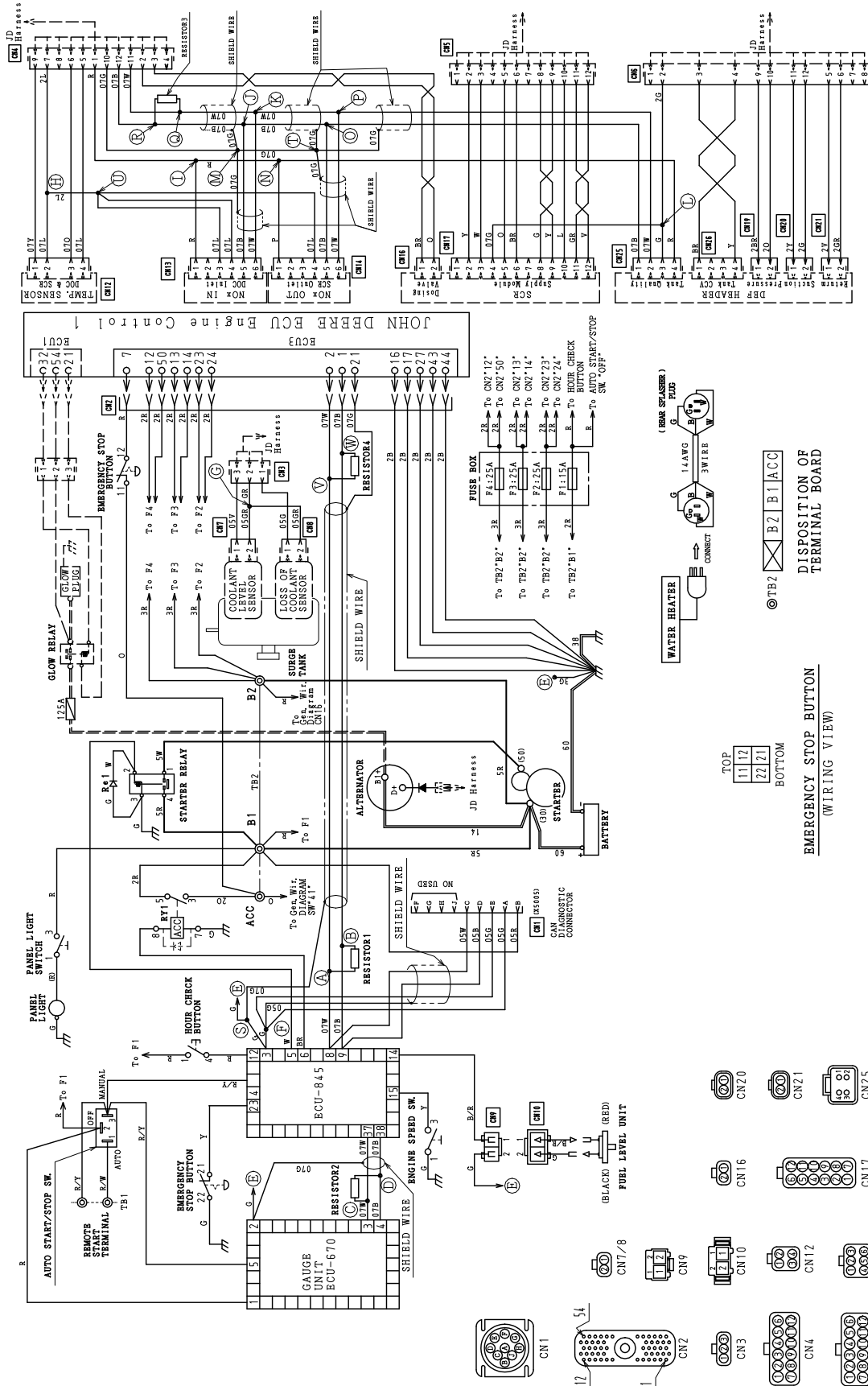

WIRE SIZE		COLOR CODE	
60	60 mm <sup>2</sup>	WIRE COLOR	WIRE COLOR
38	38 mm <sup>2</sup>	B	BLACK
14	14 mm <sup>2</sup>	L	BLUE
5	5 mm <sup>2</sup>	BR	BROWN
3	3 mm <sup>2</sup>	Z	ZINC
2	2 mm <sup>2</sup>	G	GREEN
07	0.75 mm <sup>2</sup>	GR	GRAY
05	0.5 mm <sup>2</sup>	V	VIOLET
SHIELD WIRE: SPIRAL SHIELDED WIRE		P	PINK
APPROXIMATE WIRE SIZE: 1.25 mm <sup>2</sup> and 1.5 mm <sup>2</sup>			
WIRE COLOR/LINE COLOR			

EMERGENCY STOP BUTTON  
(WIRING VIEW)

TOP  
11 | 12  
21 | 21  
BOTTOM

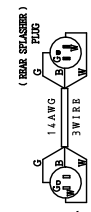

DISPOSITION OF  
TERMINAL BOARD

CONNECTOR ARRANGEMENT  
(WIRING VIEW)

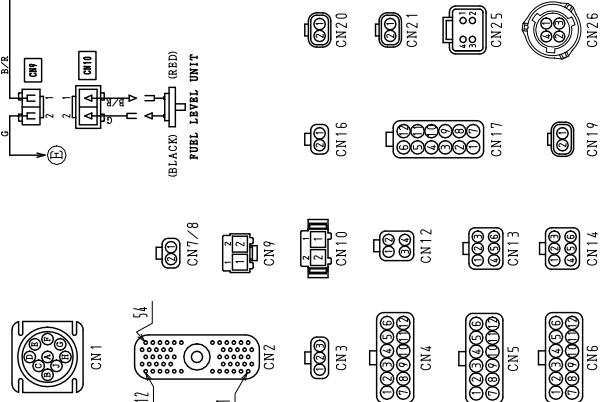

ENGINE WIRING DIAGRAM NO. M2814100513

# BATTERY CHARGER WIRING DIAGRAM (OPTION)

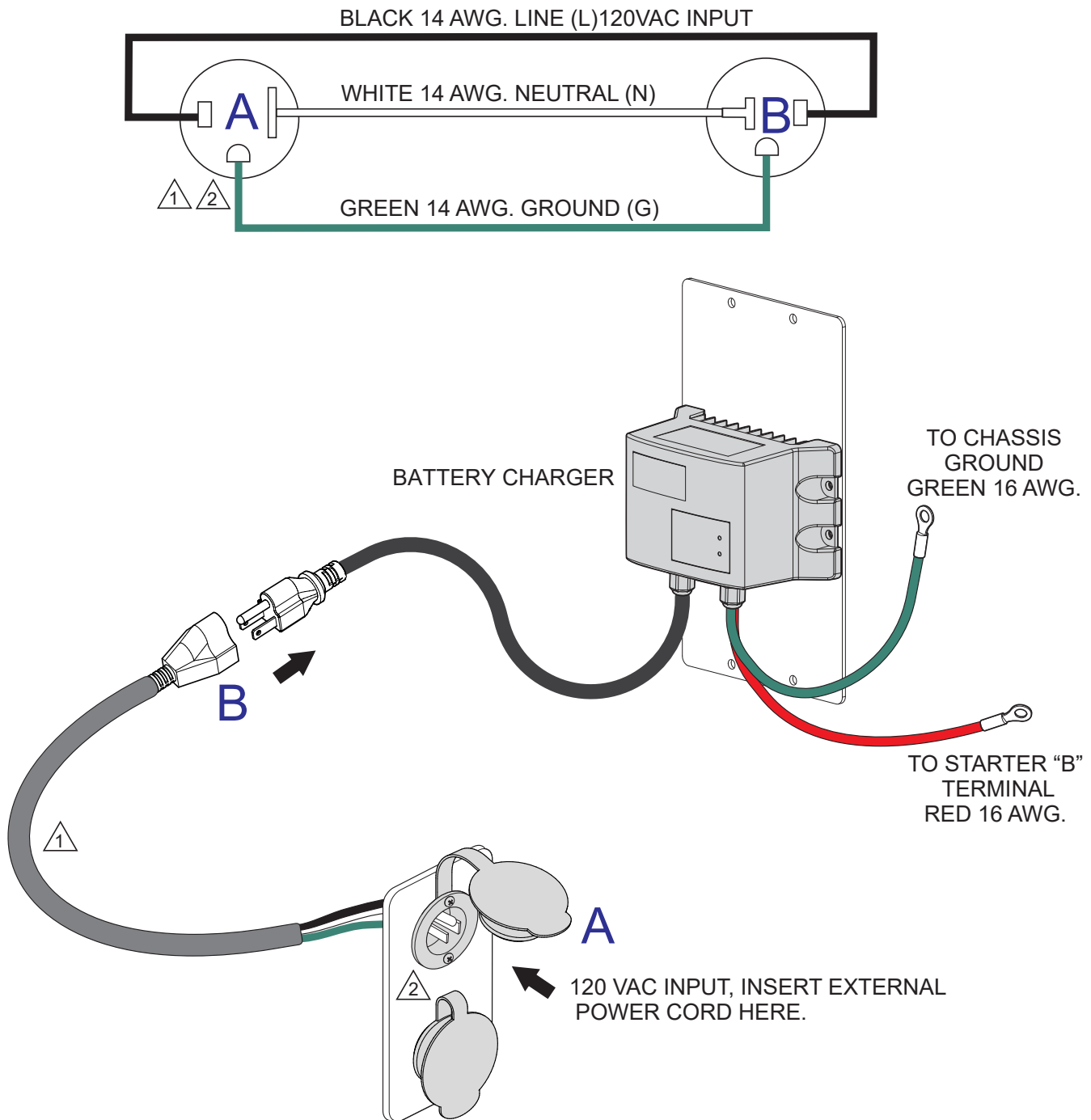



# OPERATION MANUAL

## HERE'S HOW TO GET HELP

PLEASE HAVE THE MODEL AND SERIAL  
NUMBER ON HAND WHEN CALLING

### UNITED STATES

#### *Multiquip Inc.*

(310) 537- 3700  
6141 Katella Avenue Suite 200  
Cypress, CA 90630  
E-MAIL: [mq@multiquip.com](mailto:mq@multiquip.com)  
WEBSITE: [www.multiquip.com](http://www.multiquip.com)

---

### CANADA

#### *Multiquip*

(450) 625-2244  
4110 Industriel Boul.  
Laval, Quebec, Canada H7L 6V3  
E-MAIL: [infocanada@multiquip.com](mailto:infocanada@multiquip.com)

### UNITED KINGDOM

#### *Multiquip (UK) Limited Head Office*

0161 339 2223  
Unit 2, Northpoint Industrial Estate, Globe Lane,  
Dukinfield, Cheshire SK16 4UJ  
E-MAIL: [sales@multiquip.co.uk](mailto:sales@multiquip.co.uk)

© COPYRIGHT 2023, MULTIQUIP INC.

Multiquip Inc, the MQ logo are registered trademarks of Multiquip Inc. and may not be used, reproduced, or altered without written permission. All other trademarks are the property of their respective owners and used with permission.

This manual MUST accompany the equipment at all times. This manual is considered a permanent part of the equipment and should remain with the unit if resold.

The information and specifications included in this publication were in effect at the time of approval for printing. Illustrations, descriptions, references and technical data contained in this manual are for guidance only and may not be considered as binding. Multiquip Inc. reserves the right to discontinue or change specifications, design or the information published in this publication at any time without notice and without incurring any obligations.

Manufactured for  
MQ Power Inc.  
by  
DENYO MANUFACTURING CORP.

