

RONIK

ATS QUICK START GUIDE



POWERTRON®
ATS
60-1200 A, 200-480 VAC

About your ATS

The TruONE Level 3 power panel integrates switch, mechanism, controller, power supply, HMI, and all connectivity accessories into one seamless unit. The construction of this transfer switch is outlined in Figure 1.

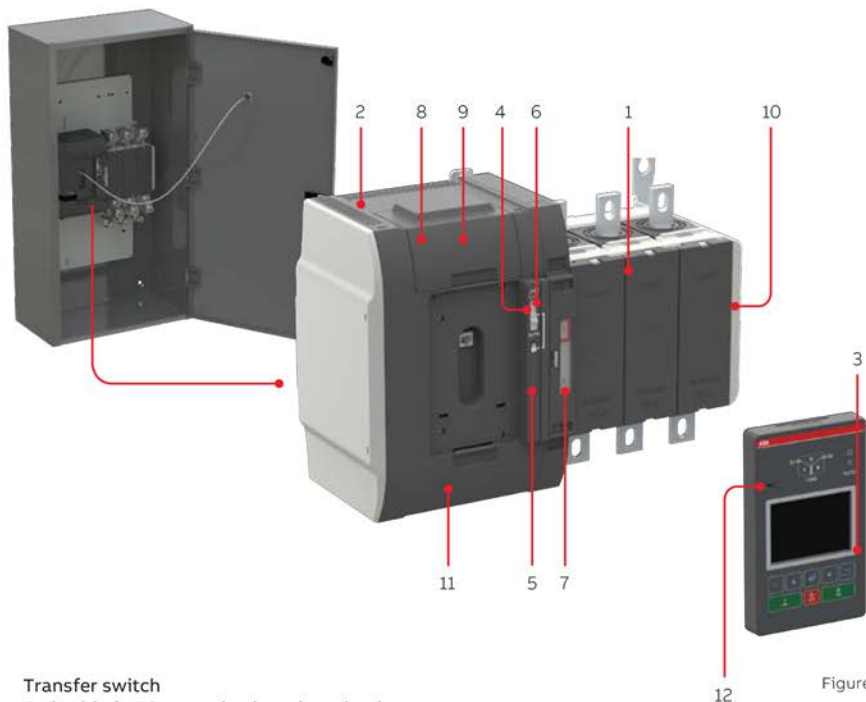

Figure 1

1. Transfer switch
2. Embedded ATS control unit and mechanism
3. LCD control interface (HMI) for configuration and automatic operation
4. Slide switch (Hand - Locking - AUTO) for selection of the operation mode
5. Padlocking the automatic transfer switch to prevent automatic and manual operation. Remark: Slide switch (Hand - Locking - AUTO) has to be in Locking position
6. Handle for manual operation
7. Position indication
8. Terminals for control circuit connections
9. Place for Ekip-modules; communication, signaling and connectivity modules
10. Auxiliary contact block mounting location
11. The product identification label
12. Programming port, only for Ekip Programming module and Ekip Bluetooth-modules

Using Ekip Programming and Ekip Connect

(Optional, laptop and Ekip Programming module required)

Ekip connect is not required because all programming can be done from the HMI. It is, however a valuable tool for offline programming or rapidly programming multiple ATS with the same program.

Programming with Ekip Connect

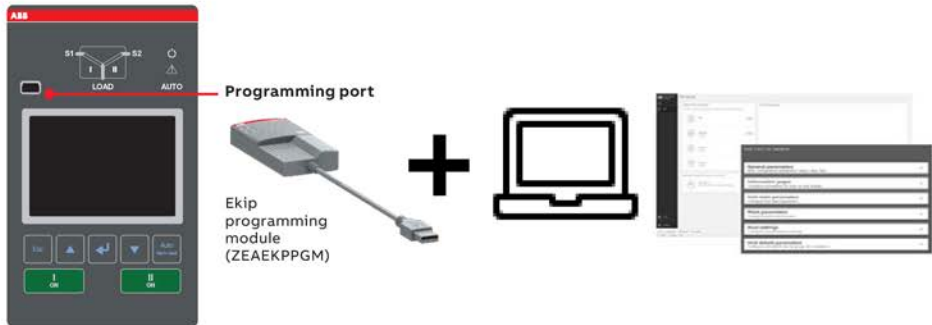

Figure 2

With Ekip Programming module and a laptop with Ekip Connect software, you can view status, set operational parameters, and configure generator exercisers on the ATS, even without any line voltage or auxiliary power connected to the panel. This USB module plugs directly to the HMI. Download the Ekip Connect software and manual from the QR code or the web address at the right.



<https://library.abb.com/en/>

Energizing

Before energizing the panel:

1. Confirm that installation has been performed by a qualified person and in accordance with NFPA 70 (NEC). Ensure this installation is properly operated and maintained in accordance with the safety practices of NFPA 70E.
2. Confirm rating label matches the installed application. For location see Figure 1, number 12.
3. Confirm that cables are connected properly and torqued according to label the ATS labeling.
4. Verify that the enclosure ground connection is properly terminated.
5. Confirm that control wiring for engine start is properly terminated to the engine start contact (located in Figure 1, number 8).
6. Additionally, connect all applicable digital I/O, communications, and auxiliary contact wiring.
7. Flip slide switch (Figure 1, number 4) to AUTO
8. Ensure that all objects and debris are removed from enclosure, and enclosure is closed and latched.

HMI keypad operation

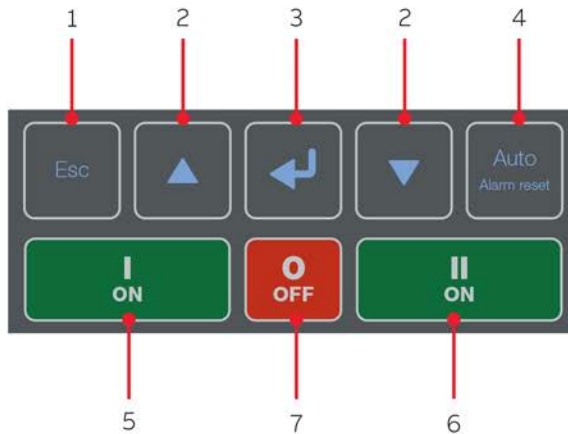

Figure 4

1. **Esc:** Step back in menu. Displays alarms when pressed from home screen.
2. **Up, Down:** Move in menu screens.
3. **Enter:** Opens menu from home screen. Select next screen, and set or confirm value or function.
4. **Auto (Alarm reset):** Resets alarms (if any). If no alarms, toggles between Manual and Auto modes.
5. **I ON:** Operate* switch to I position
6. **II ON:** Operate* switch to II position

* Slide switch (Figure 1, number 4) must be in Auto, and controller mode (Figure 4, number 4) must be in Manual.

Auto Configure

Auto configure is the first step to take after the panel is initially energized. This function recognizes the electrical system, then automatically sets all the system parameters: system voltage, frequency, and phase sequence. Follow the steps in the figure on the HMI to run auto configure. The ATS must have at least one source available to complete this step.

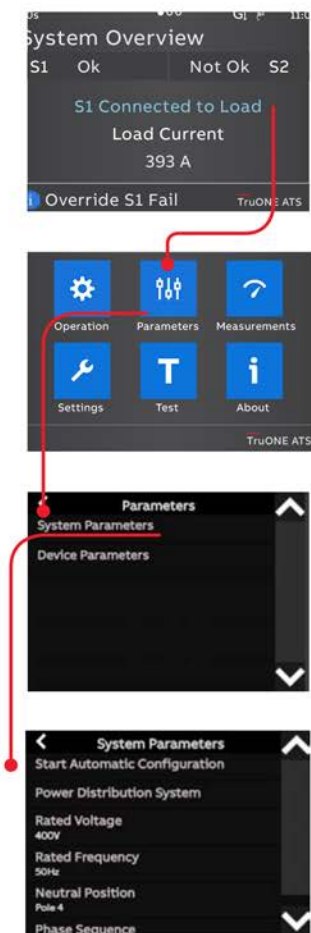

Figure 5

Settings (Optional)

| Time delays | Default Value | Possible range |
|--|---------------------------------|-------------------|
| Override momentary outage (separate for S1 and S2) | 2 s | 0-60 s |
| Transfer from S1 to S2 (separate for S2 to S1) | 2 s | 0-3600 s |
| Center-off delay | 0 s | 0-300 s |
| Generator stop | 0 s | 0-60 min |
| Set points | | |
| Voltage and frequency drop-out | ±15% of nominal | ±20% of nominal |
| Voltage and frequency pick-up | ±14% of nominal | ±19.5% of nominal |
| In-phase Monitor | Off | Off, On |
| Manual Retransfer | Off | Off, On |
| Commit Transfer | Off | Off, On |
| Application | S1-Transformer/ S2-Generator | See manual |

Table 2

Settings can be changed via the HMI as shown in Figure 6. A password is required to change parameters; the default password is 00001. Alternatively, settings can be changed with Ekip Connect 3 software using Ekip Programming module.

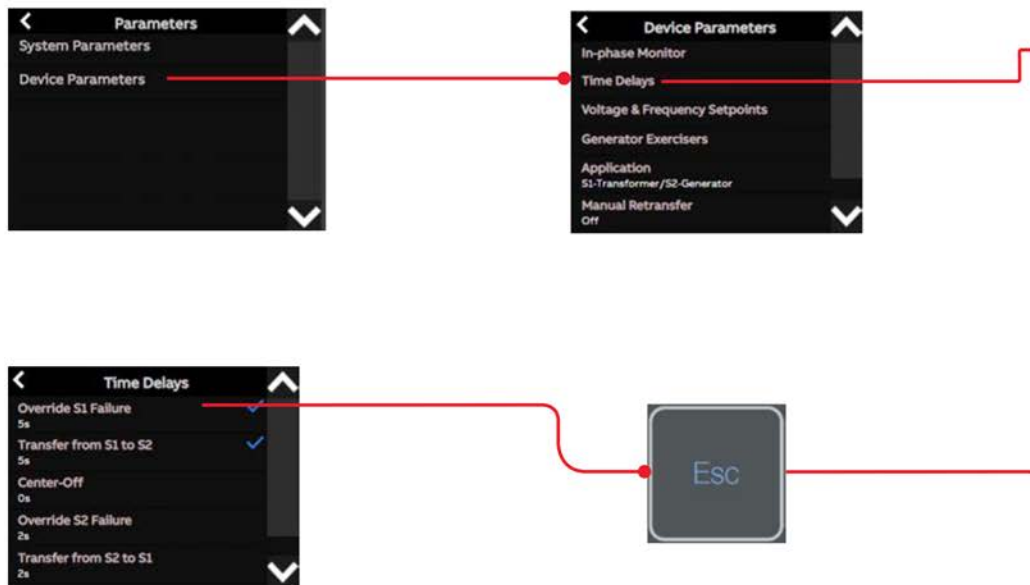

Settings (Optional)

If the standard I/O or any com modules such as Ekip 2k Signaling I/O must be programmed, these can be set in the same manner, by following the appropriate path below from the main menu.

Settings>Standard I/O Settings or Settings>Modules

Figure 6

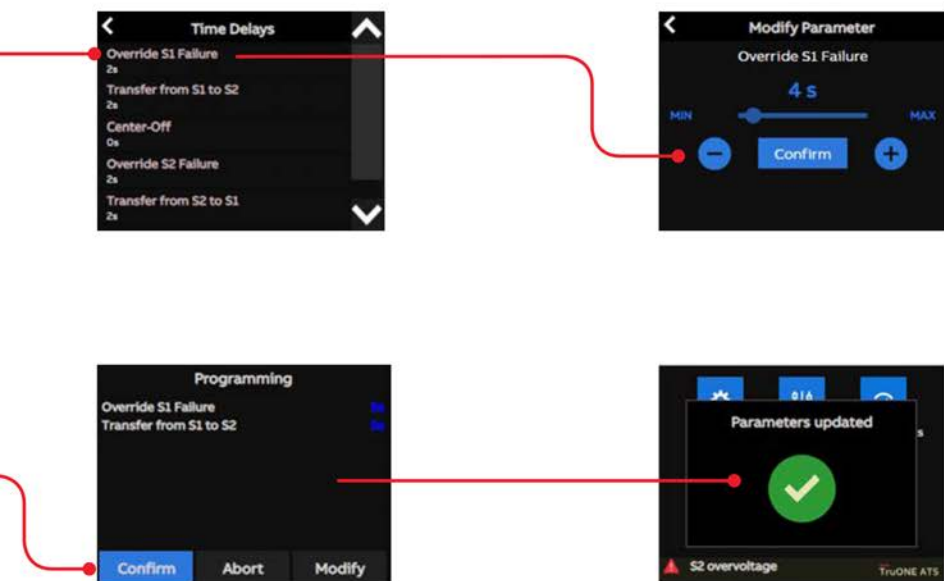

Confirm Automatic Operation

To put your ATS into Auto mode, confirm the slide switch is in “AUTO” before the enclosure door is closed. This slide switch overrides the Auto/Manual mode set from the HMI. To place ATS controller in auto mode, press the auto key on the HMI as in Figure 7. If already in Auto mode, pressing this key will take the switch out of Auto mode.

Confirm the ATS is in Auto mode by validating that the “AUTO” LED above and to the right of the LCD screen is solid green.

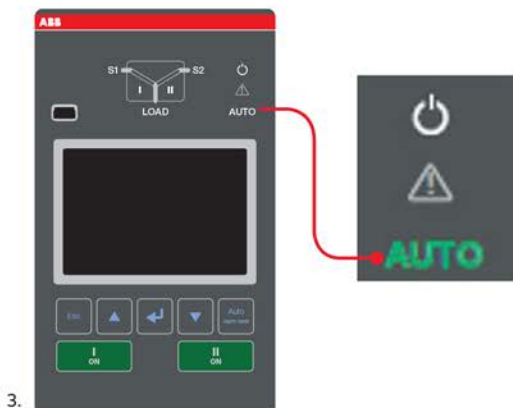
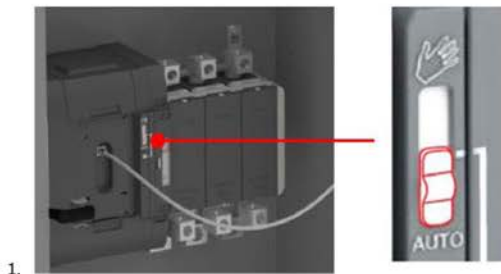

Figure 7

Test

Run an off-load test to verify the ATS-generator control connection. Follow steps in Figure 8. Backup source (generator) should start and be indicated by solid green LED for secondary source. Repeating this sequence will turn off generator.



Figure 8

To test ATS-generator auto operation, while in auto mode, simulate a primary source failure by opening the circuit breaker immediately upstream to the ATS's primary source. Verify the ATS switches to the backup source according to set-point and time delay parameters. Reclose the breaker feeding the primary source. If the ATS returns to primary source as expected, the ATS function in Auto mode is validated.