

FRONT VIEW

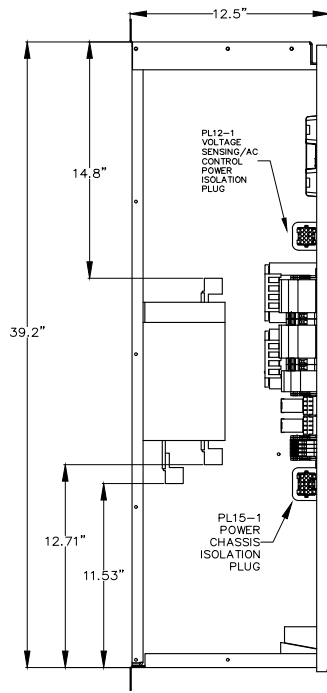

LHS VIEW
(SIDE COVER REMOVED)

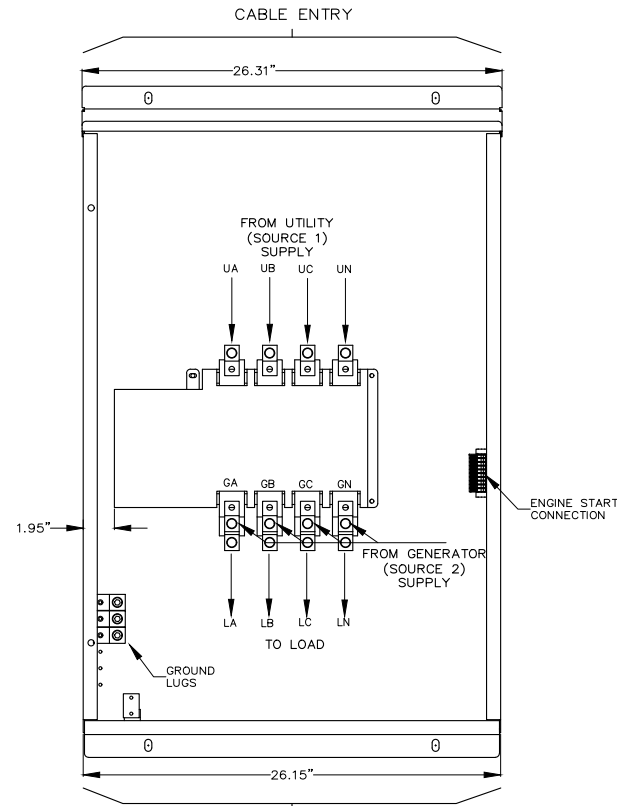

CABLE ENTRY
INTERIOR FRONT VIEW
(DOOR NOT SHOWN)

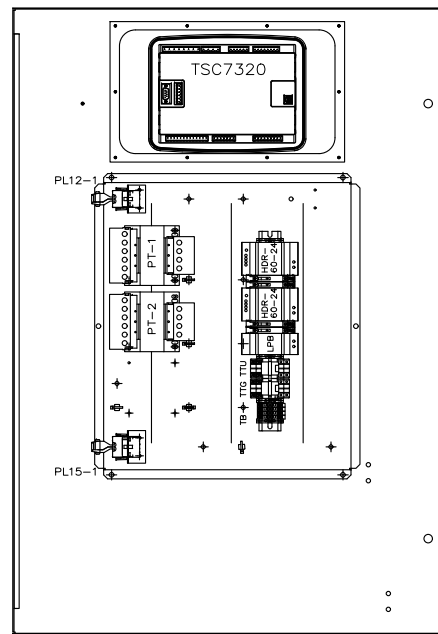

VIEWED FROM REAR
(INSIDE) OF DOOR

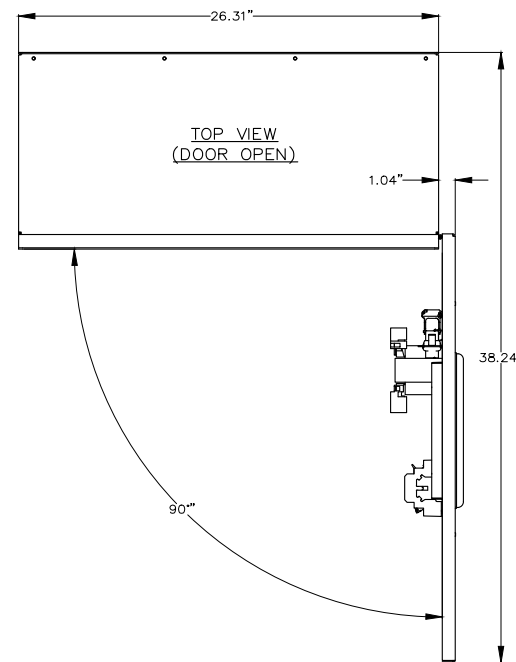

TOP VIEW
(DOOR OPEN)

CONNECTION DATA		
150A ATS	UTILITY (SRC1)	1C, #6-300MCM Cu/Al PER PHASE & NEUTRAL
	GENERATOR (SRC2)	1C, #6-300MCM Cu/Al PER PHASE & NEUTRAL
	LOAD	1C, #6-300MCM Cu/Al PER PHASE & NEUTRAL
	GROUND	3C, #14-2/0 Cu/Al
200A ATS	UTILITY (SRC1)	1C, #6-300MCM Cu/Al PER PHASE & NEUTRAL
	GENERATOR (SRC2)	1C, #6-300MCM Cu/Al PER PHASE & NEUTRAL
	LOAD	1C, #6-300MCM Cu/Al PER PHASE & NEUTRAL
	GROUND	3C, #14-2/0 Cu/Al
250A ATS	UTILITY (SRC1)	1C, #6-350MCM Cu/Al PER PHASE & NEUTRAL
	GENERATOR (SRC2)	1C, #6-350MCM Cu/Al PER PHASE & NEUTRAL
	LOAD	1C, #6-350MCM Cu/Al PER PHASE & NEUTRAL
	GROUND	3C, #14-2/0 Cu/Al

GENERAL NOTES	
1	NEMA 12 / NEMA 3R SD ENCLOSURE C/W GASKETING
2	FOR 1 PHASE, 3 WIRE SOLID NEUTRAL APPLICATION, CONNECT PHASE TO 'A' & 'B'. OMIT 'C'
3	FOR 1 PHASE, 3 WIRE SWITCHED NEUTRAL APPLICATION, CONNECT PHASE TO 'A' & 'B'. CONNECT NEUTRAL TO 'C'
4	REFER COVER PAGE / SELECTED OPTION LIST FOR PROJECT SPECIFIC DETAILS

2.5" x 5"

⚠ DANGER PELIGRO

Arc Flash and Shock Hazard
Will cause severe injury or death. Match the one line circuit - see diagram. Disconnect all sources of supply before servicing. This equipment must be installed and serviced only by qualified electrical personnel utilizing safe work practices and appropriate Personal Protective Equipment (PPE). Failure to comply may result in injury or death! Refer to NFPA 70E for minimum PPE requirements.

Risque d'Arc Electrique et d'Electrocution
Peut causer des blessures graves ou la mort. Plus d'un circuit sous tension - voir schéma. Couper toutes les sources d'alimentation avant de faire l'entretien et les réparations. Ce matériel doit être installé et entretenu uniquement par un électricien qualifié. Ce dernier doit connaître les pratiques de travail sécuritaires et porter l'équipement de protection individuelle approprié. Le non respect peut entraîner des blessures ou la mort. Reportez-vous à NFPA 70E pour le manuel des exigences minimales PPE.

Riesgo de Arco y Choque Eléctrico
Se causarían lesiones graves o muerte. Más de un circuito energizado - ver diagrama. Desconectar todas las fuentes de suministro antes de hacer mantenimiento. Este equipo solo se debe instalar y mantener por personal calificado, usando medidas de seguridad y equipo de protección personal adecuados. No seguir estas recomendaciones puede causar lesiones o muerte! Consultar la NFPA 70E para los requisitos mínimos del equipo de protección personal (PPE)

QTY = 1

APPROVED FOR CONSTRUCTION
 MASTER COPY REFERENCE COPY OF _____
 MULTIPLE UNIT WORK ORDER
 RELEASED FOR INFORMATION
 AUTH. BY: _____ DATE: _____

CROSS REFERENCE LEGEND
 50C-C-1
 GRID COORDINATE
 SHEET No. _____

DRAWING No.	REFERENCE DRAWINGS	No.	REVISIONS	BY	DATE



AUTOMATIC TRANSFER SWITCH
 MODEL TS 970
 PHYSICAL LAYOUT & INSTALLATION DETAILS
 150-250A, 4P, NEMA 1/2/12/3R SD, PCS ATS, STD

FOR REVIEW ONLY

DRAWINGS AND/OR OTHER TECHNICAL INFORMATION SUPPLIED BY THOMSON POWER SYSTEMS AS A PART OF A SALE OF EQUIPMENT ARE FOR THE PURCHASER'S USE SOLELY IN CONJUNCTION WITH THAT EQUIPMENT, UNLESS SPECIFICALLY AGREED TO OTHERWISE AS A PART OF THE TERMS OF SALE.

CUSTOMER THOMSON POWER SYSTEMS			
CUSTOMER ORDER No. C-XXXXXX	WORK ORDER No. W-XXXXXX		
DRAWN BY SK	AUTH BY OG	DATE 22-11-08	REV 0
DRAWING/FILE No. PCS970M305			SHEET 10A